OKIDATA[®]
Service Manual

ML393Plus // ML393C Plus
Dot Matrix Printers

Adobe Acrobat printable reference
copy of the OKIDATA Service Training Manual.
09/17/97

Note: This Adobe Acrobat version of the Okidata Service Training Manual was built with the pictures rendered at 300 dpi, which is ideal for printing, but does not view on most displays well.

Service Guide ML393/ML393CPlus

0 About This Manual

Front Cover	1
Copyright	2

1 Specifications

1.1 Overview - General Information/Specifications	3
1.2 Physical Specifications	4
1.3 Power Requirements	5
1.4 Environmental Conditions	6
1.5 Agency Approvals	7
1.6 Operational Specifications - Character Matrix Sizes	8
....1.6.02 Characters Per Line	9
....1.6.03 Character Pitches	10
....1.6.04 Character Sets	11
....1.6.05 Emulations	12
....1.6.06 Fonts	13
....1.6.07 Front Panel Switches	14
....1.6.08 Graphics Resolution	15
....1.6.09 Interface	16
....1.6.10 Line Feed Increments	17
....1.6.11 Line Feed Time	18
....1.6.12 Menu Mode	19
....1.6.13 Paper Feed Methods	20
....1.6.14 Paper Feed Paths	21
....1.6.15 Paper Loading	22
....1.6.16 Paper Out Detection	23
....1.6.17 Paper Tear Capabilities	24
....1.6.18 Print Method	25
....1.6.19 Print Modes	26
....1.6.20 Print Speed	27
1.7 Paper Specifications	28
1.8 Memory Specifications	29
1.9 Consumables	30
1.10 Options	31
1.11 Reliability	32

2 Principles of Operation

2.1 Principles of Operation - General Information	33
....2.1.02 Microprocessors (MPUs) and Peripheral Circuits	34
....2.1.03 Initialization	35
....2.1.04 Interface Control	36
....2.1.05 Printhead Drive Circuit	37
....2.1.06 Spacing Drive Circuit	38
....2.1.07 Line Feed Circuit	39

Table of Contents

Page

....2.1.08 Alarm Circuits	40
....2.1.09 Paper End Detection Circuit	41
....2.1.10 Power Supply	42
2.2 Mechanical Operation - Printhead Mechanism	43
....2.2.02 Spacing	44
....2.2.03 Ribbon Drive	45
....2.2.04 Paper Feed	46
....2.2.05 Paper-End Detection	47
....2.2.06 Paper Park	48
....2.2.07 Automatic Paper Loading	49
3 Maintenance	
3.1 Maintenance - General Information	50
3.2 Disassembly/Assembly Procedures - General Information	51
....3.2.01 Preliminary Items, Printhead	52
....3.2.02 Ribbon Guide	53
....3.2.03 Ribbon Protector	54
....3.2.04 Upper Cover Assembly	55
.....Parts List	56
....3.2.05 Operator Panel Assembly	57
....3.2.06 Control Board (LQEM)	58
....3.2.07 Interface Connector Board (LQPN)	59
....3.2.08 Printer Mechanism	60
....3.2.09 Platen Assembly	61
....3.2.10 Line Feed Motor	62
....3.2.11 Printhead Cable Assembly	63
....3.2.12 Sensor Board	64
....3.2.13 Ribbon Feed Assembly	65
....3.2.14 Space Motor Assembly	66
....3.2.15 Space Belt	67
....3.2.16 Bail/Ribbon Motor Assembly	68
....3.2.17 Paper Bail Assembly	69
....3.2.18 Carriage and Carriage Shaft	70
.....Parts List	71
....3.2.19 Paper Pressure Guide	72
....3.2.20 Printhead Gap / Release Lever Microswitches	73
....3.2.21 Push Tractor Assembly	74
.....Procedure - Installation Notes	75
....3.2.22 Power Supply Unit	76
....Microline 393C-Plus - Color Model Only : Sections 3.2.23 through 3.2.28	77
.....3.2.23 Ribbon Shift Arm Spring / Ribbon Shift Arm : Microline 393C-Plus - Color Model Only	78
.....3.2.24 Roller Lever : Microline 393C-Plus - Color Model Only	79

Table of Contents

Page

.....3.2.25 Ribbon Guide : Microline 393C-Plus - Color Model Only	80
.....3.2.26 Bail Open Cam and Bail Open Gear : Microline 393C-Plus - Color Model Only	81
.....3.2.27 Ribbon Shift Cam and Ribbon Shift Gear : Microline 393C-Plus - Color Model Only	82
.....3.2.28 Ribbon Shift Cam Lever Assembly : Microline 393C-Plus - Color Model Only	83
....Cut Sheet Feeder - Option : Sections 3.2.29 Through 3.2.35	84
.....3.2.29 Friction Sheet	85
.....3.2.30 Rear Bin	86
.....3.2.31 Side Cover	87
.....3.2.32 Roller Supports and Rollers (H)	88
.....3.2.33 Control Board	89
.....3.2.34 Connection Cord	90
.....3.2.35 Motor Assembly	91
3.3 Printer Adjustments - General Information	92
....3.3.02 Printhead Gap Adjustment	93
....3.3.03 Line Feed Belt Tension	94
....3.3.04 Color Adjustment (Microline 393C-Plus Printer)	95
....3.3.05 Key Combinations	96
....3.3.06 Menu Operation - General Information	97
.....Menu Mode	98
.....Menu Print	99
.....Sample Menu	100
.....Menu Settings	101
.....Menu Reset	102
.....Limited Operation	103
....3.3.07 Top of Form	104
....3.3.08 Paper Park	105
....3.3.09 Forms Tear Off	106
....3.3.10 Resets	107
3.4 Cleaning	108
3.5 Lubrication - General Information	109
....3.5.02 Lubrication Schedule	110
....3.5.03 Lubrication Types and Amounts	111
....3.5.04 Areas Not Lubricated	112
....Lubrication Points (Monochrome and Color)	113
....Platen, Carriage Shaft, Idle Gear	114
....Ribbon Feed Assembly	115
....Lubrication Points (Color)	116
....Lubrication Points (Options)	117
3.6 Shipping Instructions	118

4 Failure Analysis

Table of Contents

Page

4.1 Overview	119
4.2 Reporting Problems	120
4.3 Troubleshooting Updates	121
4.4 Troubleshooting Tips - Preliminary Checks	122
....4.4.02 Problem Categories	123
....4.4.03 START HERE Flowchart	124
....4.4.04 Tips for Preventing Image Problems	125
....4.4.05 Common Problems	126
.....Epson / IBM, Self Test Revision 1.16 (FCO 7681)	127
.....Missing Spaces When Printing Wide Reports (FCO 7693)	128
.....Self Test Revisions 1.07 and 1.10 (FCO 7730)	129
.....Parallel Timing Specification Changes	130
.....Jumper SP2 Added to Main Control Board	131
.....Font Name Changes in Menu Mode	132
.....Modifications to Q6, Main Control Board	133
4.5 Abnormal Output	134
4.6 Fault Alarms	135
4.7 Repair Analysis Procedures (RAPS)	136
....RAP 01: Power Lamp Does Not Light	137
....RAP 02: Space Error (ALARM 57)	138
....RAP 03: Head Homing Error (ALARM 53)	139
....RAP 04: Ribbon Homing Error (ALARM 5B)	140
....RAP 05: Bail Home Error (ALARM 5C)	141
....RAP 06: Wrong Character, Character Omission, or Dot Omission	142
....RAP 07: Ribbon Feed Trouble	143
....RAP 08: Line Feed Trouble	144
....RAP 09: Malfunction of Operator Panel Switch	145
....RAP 10A: Data Receive Failure	146
....RAP 10B: Parallel Interface Problem	147
....RAP 10C: Serial Interface Problem	148
....RAP 10D: Data Receive Failure (Alarm Light Lit)	149
....RAP 11: Color Ribbon Shift Problem	150
4.8 Printer Tests - General Information	151
....4.8.02 Rolling ASCII Print Test	152
....4.8.03 Font Test	153
....4.8.04 Serial Interface - Loopback Test	154
....4.8.05 Hexadecimal Dump	155
4.9 Resistance Checks - General Information	156
....4.9.02 Printhead Resistance Check	157
....4.9.03 Line Feed Motor Resistance Check	158
....4.9.04 Space Motor Resistance Check	159
....4.9.05 Ribbon Motor Resistance Check	160

A Board Diagrams

Table of Contents**Page**

A.1 Overview - General Information	161
A.2 Index To Charts	162
....A.2.01 Main Control Board (LQEM)	163
....A.2.02 Power Supply	164
....A.2.03 Interface Board (LQPN)	165
....A.2.04 Sensor Board (LQEW or LPRW)	166
....A.2.05 Operator Panel Board (LQSX)	167
B Illustrated Parts Listing	
B.1 Overview - General Information	168
....B.1.02 Definition of Terms	169
....B.1.03 Parts Ordering Information	170
B.2 Charts	171
....B.2.01 Printer Unit	172
....B.2.02 Upper Cover Assembly	173
....B.2.03 Printer Unit General Assembly (1 of 2)	174
....B.2.04 Printer Unit General Assembly (2 of 2)	175
....B.2.05 Operator Panel Assembly	176
....B.2.06 Printer Mechanism - Monochrome (1 of 3)	177
....B.2.07 Printer Mechanism - Monochrome (2 of 3)	178
....B.2.08 Printer Mechanism - Monochrome (3 of 3)	179
....B.2.09 Printer Mechanism - Color (1 of 3)	180
....B.2.10 Printer Mechanism - Color (2 of 3)	181
....B.2.11 Printer Mechanism - Color (3 of 3)	182
....B.2.12 Carriage Assembly - Monochrome	183
....B.2.13 Carriage Assembly - Color	184
....B.2.14 Options	185
....B.2.15 Pull Tractor Assembly (Option)	186
....B.2.16 Packing Materials	187
....B.2.17 Consumables	188
....B.2.18 Documentation	189
....B.2.19 Service Training Kit Revision List	190
C Microline 393/393C Specifications	
C.1 Overview - General Information	191
C.2 Printer Specifications	192
C.3 Paper Specifications	193
C.4 Physical Specifications	194
C.5 Power Requirements	195
C.6 Environmental Conditions	196
C.7 Agency Approvals	197
C.8 Options	198
C.9 Consumables	199
C.10 Memory Specifications	200
C.11 Printer Reliability	201



Service Guide ML393/ML393CPlus

Chapter 0 About This Manual

Microline 393 / 393C-Plus Service Handbook

This document may not be reproduced without the written permission of the Okidata Technical Training Group. Every effort has been made to ensure the accuracy of the information contained in this training course. Okidata is not responsible for errors beyond its control.

© 1995 by Okidata All rights reserved.

First Edition April 1990P/N 59241601

Second Edition February 1995P/N 59241602

Written and produced by the Okidata Sales and Product Training

Please address any comments on this publication to:

Sales and Product Training
Okidata
532 Fellowship Road
Mount Laurel, NJ 08054-3499

Fax Number: (609) 222-5320

Okilink Login Name: Technical Training

OKIDATA is a registered trademark of Oki Electric Industry Company, Ltd.; marques deposee de Oki Electric Industry Company, Ltd.; marca registrada, Oki Electric Industry Company, Ltd.

MICROLINE is a registered trademark of Oki Electric Industry Company, Ltd.; marque depose de Oki Electric Industry Company, Ltd.

Centronics is a registered trademark of Centronics Inc.

PLUG 'n PRINT is a registered trademark of Oki America, Inc.; marque deposee de Oki America, Inc.

Epson is a registered trademark of Seiko Epson Corporation.

IBM, Proprinter and Proprinter XL are registered trademarks of International Business Machines, Inc.

Copyright 1997, Okidata, Division of OKI America, Inc. All rights reserved. See the OKIDATA Business Partner Exchange (BPX) for any updates to this material. (<http://bpx.okidata.com>)

1.1 OVERVIEW

1.1.01 General Information

The Microline 393-Plus and Microline 393C-Plus are high speed, dot matrix printers, which utilize a 24 pin printhead.

The Microline 393-Plus is the standard version (monochrome).

The Microline 393C-Plus is the color capable version.

The printers are capable of emulating the Epson LQ-2550 and the IBM Proprinter XL24 printers.

Both an RS232-C Serial Interface and a Centronics Parallel Interface are standard.

Copyright 1997, Okidata, Division of OKI America, Inc. All rights reserved. See the OKIDATA Business Partner Exchange (BPX) for any updates to this material. (<http://bpx.okidata.com>)



1.2 PHYSICAL SPECIFICATIONS

1.2.01 Dimensions

NOTE: *Dimensions INCLUDE the platen knob, acoustic cover, and paper separator.*

Width: 25.2 inches (54 centimeters)

Depth: 19 inches (48.3 centimeters)

Height: 8 inches (20.3 centimeters)

1.2.02 Printer Weight

37 pounds (16.8 kilograms)

UPS Shippable

Copyright 1997, Okidata, Division of OKI America, Inc. All rights reserved. See the OKIDATA Business Partner Exchange (BPX) for any updates to this material. (<http://bpx.okidata.com>)



1.3 POWER REQUIREMENTS

1.3.01 Input Power

120 VAC: +10 / -15%

220 VAC: +10 / -15%

1.3.02 Power Consumption

Operating: 180 VA

Idle: 50 VA

1.3.03 Power Frequency

50/60 Hz +/- 2%

Copyright 1997, Okidata, Division of OKI America, Inc. All rights reserved. See the OKIDATA Business Partner Exchange (BPX) for any updates to this material. (<http://bpx.okidata.com>)



1.4 ENVIRONMENTAL CONDITIONS

1.4.01 Acoustic Rating

Letter Quality Mode

58 dBA

Quiet Mode

54 dBA

1.4.02 Altitude

10,000 feet (3,048 meters)

1.4.03 Ambient Temperature and Relative Humidity (RH)

While operating: 41 to 104 degrees Fahrenheit (5 to 40 degrees Celsius)

Operating humidity: 20% to 90% RH

While in storage: -40 to 158 degrees Fahrenheit (- 40 to 70 degrees Celsius)

Storage humidity: 5% to 95% RH



1.5 AGENCY APPROVALS

1.5.01 Listings

UL No: UL Standard No. 478

CSA No: CSA Standard C22.2 (220)

FCC: FCC Class B

Copyright 1997, Okidata, Division of OKI America, Inc. All rights reserved. See the OKIDATA Business Partner Exchange (BPX) for any updates to this material. (<http://bpx.okidata.com>)

1.6 OPERATIONAL SPECIFICATIONS

1.6.01 Character Matrix Sizes

Table of Print Speed and Character Matrix

Mode	Speed	Matrix (Horizontal x Vertical) @ cpi
Letter Quality	140 cps	30 x 18 @ 12 cpi
Near Letter Quality	210 cps	15 x 18 @ 12 cpi
Utility	415 cps	9 x 17 @ 12 cpi
High Speed Draft	520 cps	7 x 17 @ 15 cpi

Copyright 1997, Okidata, Division of OKI America, Inc. All rights reserved. See the OKIDATA Business Partner Exchange (BPX) for any updates to this material. (<http://bpx.okidata.com>)



1.6.02 Characters Per Line

Characters Per Line	Characters Per Inch (Maximum)
136	10
163	12
204	15
233	17.1
272	20
PS	-

Copyright 1997, Okidata, Division of OKI America, Inc. All rights reserved. See the OKIDATA Business Partner Exchange (BPX) for any updates to this material. (<http://bpx.okidata.com>)



1.6.03 Character Pitches

10, 12, 15, 17.1, 20

Copyright 1997, Okidata, Division of OKI America, Inc. All rights reserved. See the OKIDATA Business Partner Exchange (BPX) for any updates to this material. (<http://bpx.okidata.com>)



Service Guide ML393/ML393CPlus

Chapter 1 Specifications

1.6.04 Character Sets

Standard ASCII

EPSON Character Set I & II

IBM Character Set I, II & All Characters

16 Foreign Language Sets

Zero / Slashed Zero

DLL - 2 Sets of 128 characters

Copyright 1997, Okidata, Division of OKI America, Inc. All rights reserved. See the OKIDATA Business Partner Exchange (BPX) for any updates to this material. (<http://bpx.okidata.com>)



1.6.05 Emulations

NOTE: The emulations are co-resident

Epson LQ

IBM XL24

Copyright 1997, Okidata, Division of OKI America, Inc. All rights reserved. See the OKIDATA Business Partner Exchange (BPX) for any updates to this material. (<http://bpx.okidata.com>)



Service Guide ML393/ML393CPlus

Chapter 1 Specifications

1.6.06 Fonts

Standard

Courier

Swiss

Roman

Orator

Optional Font Cartridges

Prestige

Letter Gothic

Copyright 1997, Okidata, Division of OKI America, Inc. All rights reserved. See the OKIDATA Business Partner Exchange (BPX) for any updates to this material. (<http://bpx.okidata.com>)



Service Guide ML393/ML393CPlus

Chapter 1 Specifications

1.6.07 Front Panel Switches

SELECT Paper Park / Top of Form

Quiet (Menu) Mode Font Selection

Line Feed Pitch Selection

FORM FEED Print Quality Selection

Copyright 1997, Okidata, Division of OKI America, Inc. All rights reserved. See the OKIDATA Business Partner Exchange (BPX) for any updates to this material. (<http://bpx.okidata.com>)



Service Guide ML393/ML393CPlus

Chapter 1 Specifications

1.6.08 Graphics Resolution

60 (horizontal) x 60 (vertical) dots per inch (DPI) minimum

360 (horizontal) x 360 (vertical) dots per inch (DPI) maximum

Copyright 1997, Okidata, Division of OKI America, Inc. All rights reserved. See the OKIDATA Business Partner Exchange (BPX) for any updates to this material. (<http://bpx.okidata.com>)



Service Guide ML393/ML393CPlus

Chapter 1 Specifications

1.6.09 Interface

Standard

Centronics Parallel

19.2K Super-Speed Serial RS232C

Copyright 1997, Okidata, Division of OKI America, Inc. All rights reserved. See the OKIDATA Business Partner Exchange (BPX) for any updates to this material. (<http://bpx.okidata.com>)

1.6.10 Line Feed Increments**Fixed**

6 lines per inch (lpi) [0.167 inch (4.23 millimeters)]

8 lines per inch (lpi) [0.125 inch (3.175 millimeters)]

Variable

n/60 inch

n/72 inch

n/180 inch

n/216 inch

n/360 inch



Service Guide ML393/ML393CPlus

Chapter 1 Specifications

1.6.11 Line Feed Time

55 ms @ 6 LPI

8.0 IPS (inches per second) slew rate @ gap 1,2

6.0 IPS (inches per second) slew rate @ gap 3+

Copyright 1997, Okidata, Division of OKI America, Inc. All rights reserved. See the OKIDATA Business Partner Exchange (BPX) for any updates to this material. (<http://bpx.okidata.com>)



1.6.12 Menu Mode

Switch	Action
Print	Prints the entire menu.
Group	Selects Group Function
Item	Selects Item
Set	Selects Item Value
Exit	Exits Menu Mode Enters Select

Copyright 1997, Okidata, Division of OKI America, Inc. All rights reserved. See the OKIDATA Business Partner Exchange (BPX) for any updates to this material. (<http://bpx.okidata.com>)

1.6.13 Paper Feed Methods**Standard**

Friction Feed (Top)

Rear Push Tractor (Rear)

Optional

Pull Tractor (Bottom)

Cut Sheet Feeder (Top)

CSF 30001 - Single Bin

CSF 30002 - Dual Bin

Copyright 1997, Okidata, Division of OKI America, Inc. All rights reserved. See the OKIDATA Business Partner Exchange (BPX) for any updates to this material. (<http://bpx.okidata.com>)



Service Guide ML393/ML393CPlus

Chapter 1 Specifications

1.6.14 Paper Feed Paths

Top Feed (Standard)

Rear Feed (Standard)

Bottom Feed (by using an Optional feed mechanism)

Special Features

Paper Park

Forms Tear Off

Copyright 1997, Okidata, Division of OKI America, Inc. All rights reserved. See the OKIDATA Business Partner Exchange (BPX) for any updates to this material. (<http://bpx.okidata.com>)

1.6.15 Paper Loading

Refer to the Setup Guide or Section 2.2  of this Service Handbook for information on paper loading.

Copyright 1997, Okidata, Division of OKI America, Inc. All rights reserved. See the OKIDATA Business Partner Exchange (BPX) for any updates to this material. (<http://bpx.okidata.com>)



Service Guide ML393/ML393CPlus

Chapter 1 Specifications

1.6.16 Paper Out Detection

Distance from end of paper

Rear Feed: 2.3 inches (5.84 centimeters)

Bottom Feed: .94 inches (2.388 centimeters)

Cut Sheet: .93 inches (2.362 centimeters)

Copyright 1997, Okidata, Division of OKI America, Inc. All rights reserved. See the OKIDATA Business Partner Exchange (BPX) for any updates to this material. (<http://bpx.okidata.com>)



Service Guide ML393/ML393CPlus

Chapter 1 Specifications

1.6.17 Paper Tear Capabilities

Tear Bar (for Forms Tear-Off)

Copyright 1997, Okidata, Division of OKI America, Inc. All rights reserved. See the OKIDATA Business Partner Exchange (BPX) for any updates to this material. (<http://bpx.okidata.com>)



Service Guide ML393/ML393CPlus

Chapter 1 Specifications

1.6.18 Print Method

Printhead Type

General Information

Impact: Dot Matrix

24 pin printhead

.0078 inch (0.20 millimeter) diameter pins

Overheat Protection

When printhead temperature reaches 115 to 125 degrees Celsius, the printer stops bi-directional printing. Uni-directional printing begins.

If the temperature exceeds 125 degrees Celsius, printing stops.

Printing will resume when the printhead temperature drops below 115 degrees Celsius.

NOTE: [Refer to Section Two for more information on printhead operation](#) .

Printhead Gap Information

Two items factor into printhead gap information.

1. Printhead Gap Adjustment

This is a SERVICE ADJUSTMENT made by a technician.

It is covered in Section 3.3  of this Service Handbook.

The Adjustment measures 0.017, +/- 0.001 inches (0.43, +/- 0.03 mm).

2. Printhead Gap Adjust

This is a manual adjustment performed by the end-user.

It is performed by moving the blue head gap lever, located on the right side of the printer.

The settings are 1, 2, 3, 4, 5, 6, 7, 8, 9

1 is the smallest (narrowest) gap.

9 is the largest (widest) gap.

Setting	Paper Type
1	12 - 15 lb. paper
2	20 - 24 lb. paper
3 - 4	Labels

3 - 4	Two-part forms
4 - 5	Three-part forms
7	Four-part forms
5 - 9	Envelopes

Copyright 1997, Okidata, Division of OKI America, Inc. All rights reserved. See the OKIDATA Business Partner Exchange (BPX) for any updates to this material. (<http://bpx.okidata.com>)



Service Guide ML393/ML393CPlus

Chapter 1 Specifications

1.6.19 Print Modes

Letter Quality

Near Letter Quality

Utility

High Speed Draft

Copyright 1997, Okidata, Division of OKI America, Inc. All rights reserved. See the OKIDATA Business Partner Exchange (BPX) for any updates to this material. (<http://bpx.okidata.com>)



Service Guide ML393/ML393CPlus

Chapter 1 Specifications

1.6.20 Print Speed

Pitch	Head Gap Setting	High Speed Draft	Utility	Near Letter Quality	Letter Quality
10 cpi	1,2		345 cps	172 cps	115 cps
12 cpi	1,2		414 cps	207 cps	138 cps
15 cpi	1,2	517 cps	258 cps		172 cps
17.1 cpi	1,2	517 cps	295 cps		196 cps
20 cpi	1,2		345 cps		230 cps
10 cpi	3+		300 cps	150 cps	100 cps
12 cpi	3+		360 cps	180 cps	120 cps
15 cpi	3+	450 cps	225 cps		150 cps
17.1 cpi	3+	450 cps	257 cps		171 cps
20 cpi	3+		300 cps		200 cps

cpi - Characters Per Inch

cps - Characters Per Second

1.7 PAPER SPECIFICATIONS

CAUTION:

Use Bottom Feed and/or optional Pull Tractor for card stock and labels.

1.7.01 Types

Card Stock

Weight: 100 lbs. (375 g/m²) Maximum

Width: 5 to 14 inches (12.7 to 35.6 centimeters)

Length: 3 to 17 inches (7.62 to 43.18 centimeters)

Thickness: .014 inches (0.36 millimeters)

Paper Feed Path: Bottom

Printhead Gap Information: Refer to the Printhead Gap Information, Section 1.6

Continuous Form

Weight:

Single Part 12 - 24 lb. (45 to 90 g/m²)

Multi-Part, Carbonless 9 - 11 lb. (35 to 40 g/m²)

Multi-Part, Interleaf Paper 10 - 12 lb. (38 to 45 g/m²) Carbon 9 lb. (35 g/m²)

Width: 3.5 to 15.5 inches (8.8 to 41.9 centimeters)

Length: 3 to 17 inches (7.62 to 43.18 centimeters)

Thickness: 0.014 inches (0.36 millimeters) maximum

Paper Feed Path: Rear or Bottom

Printhead Gap Information: Refer to the Printhead Gap Information, Section 1.6

Cut Sheet

Weight: 12 to 24 lbs. (45 to 90 g/m²)

Width: 7.2 to 16 inches (18.3 to 40.6 centimeters)

Length: 3 to 17 inches (7.62 to 43.18 centimeters)

Thickness: 0.002 to .0049 inches (0.5 to 0.12 millimeters)

Paper Feed Path: Top

Printhead Gap Information: Refer to the Printhead Gap Information, Section 1.6.

Envelopes

Weight: 24 lbs. (90 g/m²) Maximum

Size:

Single Feed

Minimum: 6.5 x 3.6 inches (16.5 x 9.1 centimeters)

Maximum: 9.5 x 4.1 inches (24.1 x 10.4 centimeters)

Continuous

Non-overlap type

Thickness: .014 inches (.325 millimeters) Maximum

Paper Feed Path: Bottom

Printhead Gap Information: Refer to the Printhead Gap Information, Section 1.6.

Labels

Weight: N/A

Width: 3.5 to 15.5 inches (8.8 to 41.9 centimeters)

Length: 3 to 17 inches (7.62 to 43.18 centimeters)

Thickness: .011 inches (0.28 mm) Maximum (including backing)

Paper Feed Path: Bottom

Printhead Gap Information: Refer to the Printhead Gap Information, Section 1.6.

CAUTION:

Use Bottom Feed and/or optional Pull Tractor for card stock and labels.

Transparency

NOTE:

Roller marks may mar the transparency under high temperature / high humidity conditions.

Weight: 12 to 24 lbs. (45 to 90 g/m²)

Width: 7.2 to 16 inches (18.2 to 40.6 centimeters)

Length: 3 to 17 inches (7.62 to 43.18 centimeters)

Thickness: 0.14 inches (0.36 millimeters) maximum

Paper Feed Path: Top

Printhead Gap Information: Refer to the Printhead Gap Information, Section 1.6.

1.7.02 Length

NOTE:

The recommended length is specific to paper type. Rear Feed

Minimum 3 inches (7.62 centimeters)

Maximum 17 inches (43.18 centimeters)

Bottom Feed

Minimum 3 inches (7.62 centimeters)

Maximum 17 inches (43.18 centimeters)

Top Feed

Minimum 3 inches (7.62 centimeters)

Maximum 17 inches (43.18 centimeters)

1.7.03 Number of Copies

Original + 3 Interleaf

Original + 3 Carbonless

Original Cut Sheet

1.7.04 Thickness

0.014 inches / 0.36 mm Maximum

1.7.05 Weight

NOTE:

The recommended weight is specific to paper type. Minimum: 12 lb. (45 g/m²)

Maximum: 100 lb. (375 g/m²)

1.7.06 Width

NOTE:

The recommended width is specific to paper type.

Paper

Minimum: 3.5 inches (8.8 centimeters)

Maximum: 16 inches (40.6 centimeters)

Copyright 1997, Okidata, Division of OKI America, Inc. All rights reserved. See the OKIDATA Business Partner Exchange (BPX) for any updates to this material. (<http://bpx.okidata.com>)



Service Guide ML393/ML393CPlus

Chapter 1 Specifications

1.8 MEMORY SPECIFICATIONS

1.8.01 ROM

128 Kbytes Resident Program ROM

384 Kbytes Resident Fonts

64 Kbytes each Optional Font Cartridges

1.8.02 RAM

Total RAM = 64 Kbytes

Print Buffer 23 Kbytes

Epson I/F Buffer 8 Kbytes

IBM I/F Buffer 0 Kbytes (minimum)

DLL Buffer 0 to 32 Kbytes

1.8.03 EEPROM

Internal Control, Menu = 256 bits

Copyright 1997, Okidata, Division of OKI America, Inc. All rights reserved. See the OKIDATA Business Partner Exchange (BPX) for any updates to this material. (<http://bpx.okidata.com>)



Service Guide ML393/ML393CPlus

Chapter 1 Specifications

1.9 CONSUMABLES

1.9.01 Black Ribbon Cartridge

Microline 393-Plus and Microline 393C-Plus

Type: Fabric Ribbon

Ribbon Life: 5 million characters

1.9.02 Color Ribbon Cartridge

Microline 393C-Plus

Type: Four band color ribbon (Yellow, Magenta, Cyan, Black)

Ribbon Life:

Black: 2.3 million characters

Cyan: 1.8 million characters

Magenta: 1.8 million characters

Yellow: 1.3 million characters

1.9.03 Film Ribbon

Can be used in both the Microline 393-Plus and Microline 393C-Plus.

Ribbon Life

400K Characters at 10 cpi in letter quality mode

CAUTION:

Using a non-Okidata ribbon may damage the printhead and void any warranties.

Copyright 1997, Okidata, Division of OKI America, Inc. All rights reserved. See the OKIDATA Business Partner Exchange (BPX) for any updates to this material. (<http://bpx.okidata.com>)



Service Guide ML393/ML393CPlus

Chapter 1 Specifications

1.10 OPTIONS

1.10.01 Cut Sheet Feeders

Single Bin, CSF 30001

Single Bin with envelope capability

Paper Width: 7.2 to 8.5 inches (18.3 to 21.7 centimeters)

Paper Length: 10.1 to 14 inches (25.7 to 35.6 centimeters)

Capacity: 170 sheets (16 lb.), 100 sheets (24 lb.)

Dual Bin, CSF 3002

Dual Bin with envelope capability

Paper Width: 7.2 to 8.5 inches (18.3 to 21.7 centimeters)

Paper Length: 10.1 to 14 inches (25.6 to 35.6 centimeters)

Capacity: 170 sheets (16 lb.), 100 sheets (24 lb.)

1.10.02 Pull Tractor Kit

NOTES:

A Pull Tractor Assembly MUST be used to feed labels.

The Pull Tractor Assembly is required for bottom feeding.

Bottom Feed

Rear Feed (For Push/Pull Operation)

Paper Types: Continuous Feed and Labels

1.10.03 RAM Buffer Expansion Card

32 kbytes

1.10.04 Font Cartridges

Prestige

Gothic



Service Guide ML393/ML393CPlus

Chapter 1 Specifications

1.11 RELIABILITY

1.11.01 Mean Time Before Failure (MTBF)

Approximately 4,000 hours: 25% duty cycle / 35% page density

1.11.02 Mean Time To Repair (MTTR)

Approximately 15 minutes to major sub-assembly level

1.11.03 Printer Life

Approximately 12,000 hours of power-on time: 25% duty cycle / 35% page density

1.11.04 Printhead Life

Average 200 million characters in 10 cpi utility mode @ normal 25% duty, 35% page density

1.11.05 Ribbon Life

Approximately 4 million characters

1.11.06 Warranty (Limited)

One year, parts, labor, and printhead

1.11.07 Service

Authorized Okidata Service Centers

Copyright 1997, Okidata, Division of OKI America, Inc. All rights reserved. See the OKIDATA Business Partner Exchange (BPX) for any updates to this material. (<http://bpx.okidata.com>)

2.1 ELECTRICAL OPERATION**2.1.01 General Information**

The Control Board consists of the microprocessor and its peripheral circuits, the drive circuits. The power to the Control Board is supplied by the power supply unit. The power to the other electrical parts is distributed via the connectors on the Control Board.

Copyright 1997, Okidata, Division of OKI America, Inc. All rights reserved. See the OKIDATA Business Partner Exchange (BPX) for any updates to this material. (<http://bpx.okidata.com>)

2.1.02 Microprocessors (MPUs) and Peripheral Circuits

Microprocessors (Q16: 83C154UGS and Q11: 80C154VGS)

The Microprocessors are the nucleus of the control circuit. The peripheral circuits operate under program control by these microprocessors. The Master MPU (Q16) controls the interface, code processing and the Slave MPU. The Slave MPU (Q11) controls the spacing and printing functions.

Program ROM for Master MPU (Q6: 27512)

This Program ROM contains the control program for the printer. The master microprocessor operates by execution of this program.

Program ROM for Slave MPU (Q17: 2764)

This Program ROM contains the control program for the printer. The slave microprocessor operates by execution of this program.

DRAM (Q18 and Q19)

The Dynamic RAM chips, each consisting of 64x4 Kbits, are used as the Receive Buffer and Print Buffer. The total buffer size is 64x8 Kbits.

CGROM (Q7)

This is a 1 Mbit ROM which stores the resident character fonts.

EEPROM (Q20)

This 256-bit serial Electrically Erasable and Programmable ROM stores the menu data.

Motor Control LSI (Q9: MSM6990)

This LSI controls the functions listed below.

Space Motor Speed Control

To obtain the carriage speed instructed by the Microprocessor, the LSI generates the pulse switch timing and overdrive time

Dot ON Timing generation

I/O Port (Input port used to read Operator Panel switches)

Address Latch (for lower 8 bits of the slave MPU)

LSI (Q8: MSM74H002)

This LSI drives the 24 pin printhead. The following describes the function of the LSI.

Printhead Drive Control

Printhead Drive Correction

Modifies the drive time under the following circumstances

Correction for edge pin driving

Correction for drive voltage fluctuations

Correction for head gap setting

Interface LSI (Q12: MSM60306)

The MSM60306 is an external interface LSI and controls the following functions.

Interface Control

Controls both the parallel and serial interface functions

Pin 4 of this LSI enables selection of the serial or parallel interface

Address Latch (for lower 8 bits of the master MPU)

MMU (Memory Management Unit) LSI (Q13: MSM73003)

This LSI is connected between the Master and Slave MPUs and performs these functions.

LED Drive Output Port

Master/Slave MPU Interface

Transfers commands and data between the Master and Slave MPUs

Memory Control

Extends the addressable memory by switching banks in/out

Dynamic RAM Refresh

Block Diagram of Microline 393 / 393C-Plus

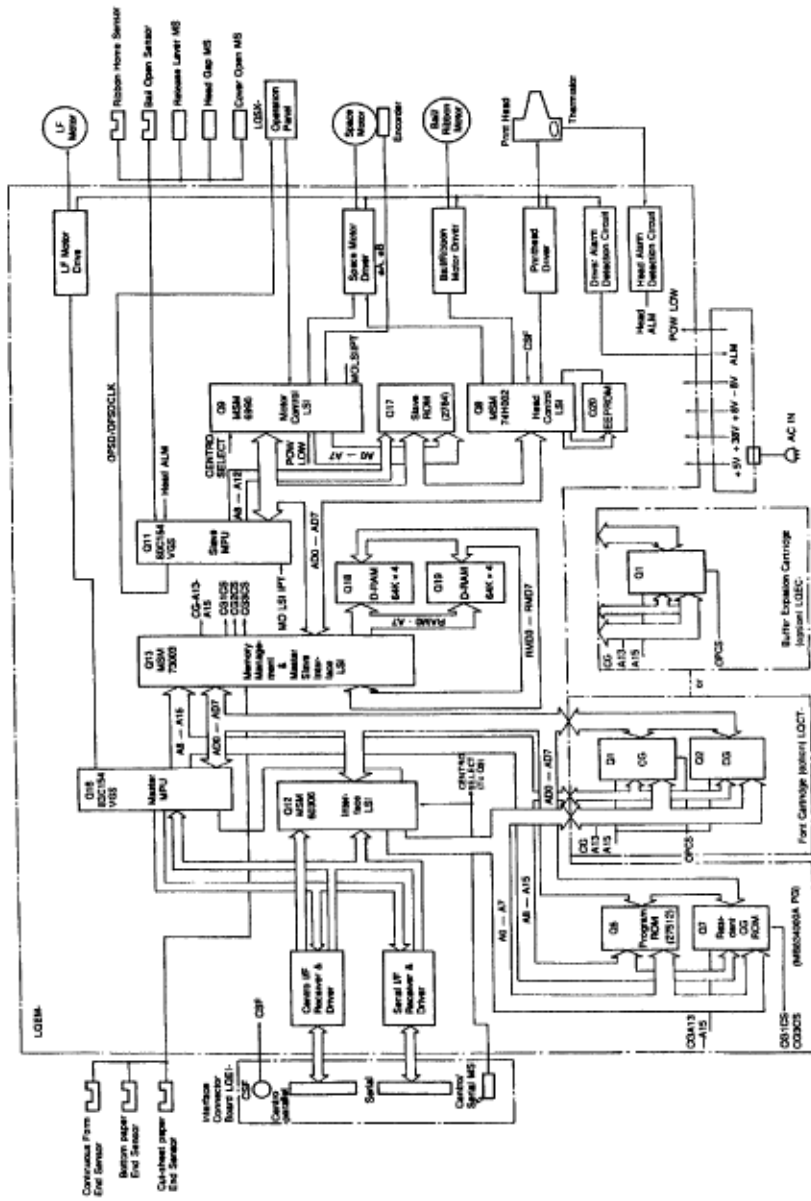

Copyright 1997, Okidata, Division of OKI America, Inc. All rights reserved. See the OKIDATA Business Partner Exchange (BPX) for any updates to this material. (<http://bpx.okidata.com>)



Service Guide ML393/ML393CPlus

Chapter 2 Principles of Operation

2.1.03 Initialization

The printer is initialized whenever the power is turned ON or when the I-PRIME signal is received at the parallel interface. Initialization is started when the RST-P signal is sent from the reset circuit to the MPUs and LSIs.

When RST-P is generated, ROM program execution starts with the mode setting of Q8, Q9, Q12 and Q13. Next, ROM and RAM are checked for errors, RAM is initialized and the carriage, bail and ribbon (color model only) are homed. The program finally establishes the interface signals (output level of ACK, BUSY, etc.), then turns the SELECT lamp ON to inform the host computer that the printer is ready to receive data.

Copyright 1997, Okidata, Division of OKI America, Inc. All rights reserved. See the OKIDATA Business Partner Exchange (BPX) for any updates to this material. (<http://bpx.okidata.com>)



Service Guide ML393/ML393CPlus

Chapter 2 Principles of Operation

2.1.04 Interface Control

The printer is capable of serial or parallel operation. The desired interface method is selected by sliding the interface cover to expose the desired connector. When this is done, the interface select switch is turned ON or OFF to inform the Interface Control LSI (Q12) of the selected interface.

Parallel Interface

When the interface select switch is turned OFF, the parallel interface is selected and the Interface Control LSI is in the parallel mode.

The data from the interface is received through connector (CN-1) and the Interface LSI (Q12) latches this data to the internal register in the LSI at the rising edge of the STB-N signal. The BUSY signal is turned ON as the data is processed. When processing is completed, the BUSY signal is turned OFF and an ACK signal is sent to the host to request more data. The BUSY signal is also turned ON when the printer is not able to receive data (buffer is full, printer is deselected or an error condition exists).

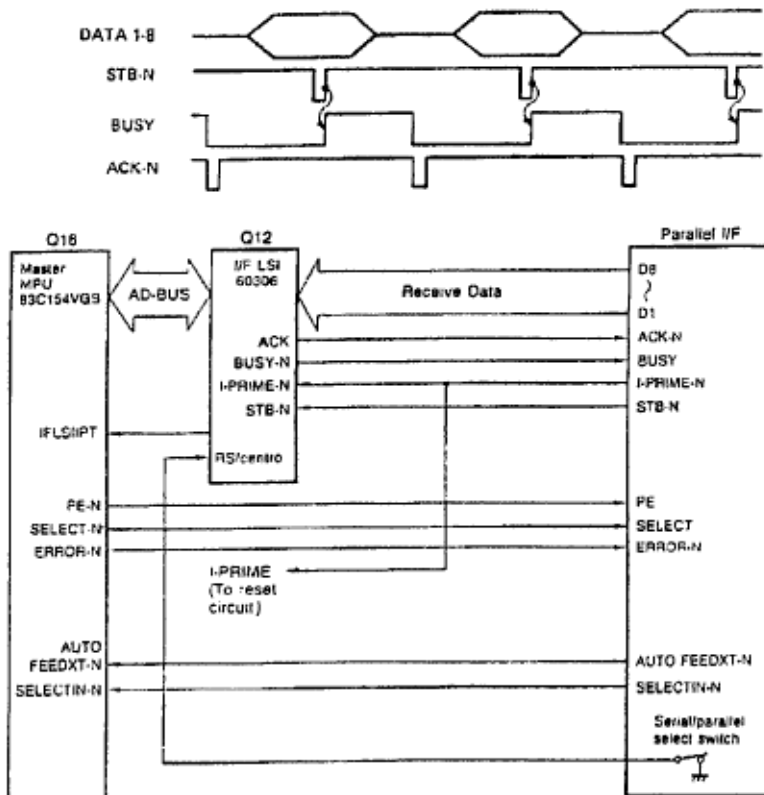

RS232-C Serial Interface

When the interface select switch is turned ON, the serial interface is selected and the Interface Control LSI is in the serial mode.

Then the RS232-C interface signals (DSR, CTS, CD and RD) are converted to TTL levels by the line receiver (Q2) and input to the Master MPU, Slave MPU and MMU. The Master MPU converts the serial data to parallel data.

The interface signals (DTR, RTS, SSD and TD) output from the Master MPU and Interface LSI are converted from TTL levels to RS232-C levels by the line driver (Q2) and sent to the serial interface connector.

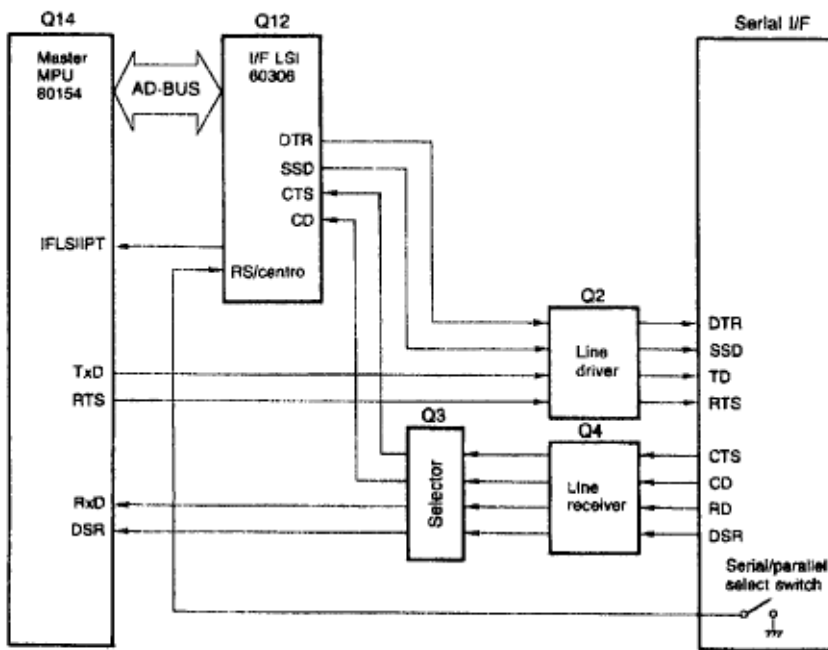
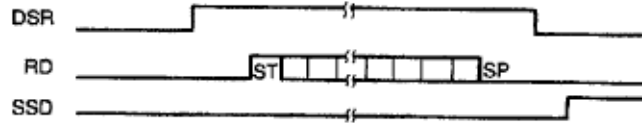

Copyright 1997, Okidata, Division of OKI America, Inc. All rights reserved. See the OKIDATA Business Partner Exchange (BPX) for any updates to this material. (<http://bpx.okidata.com>)



Service Guide ML393/ML393CPlus

Chapter 2 Principles of Operation

2.1.05 Printhead Drive Circuit

This circuit is used to drive the twenty-four (24) print wires.

The signals HD1 through HD24 control the individual print wires. The HD ON signal (even/odd trigger) enables the drive circuit when printing is desired.

The head drive duration is determined by an RC integrating circuit, which modifies the HD ON pulse width. The pulse width of the HD ON signal varies with the number of pins being driven.

Printhead Drive Time

The drive time *increases* as more pins are driven.

The drive time *decreases* as less pins are driven.

The drive time also increases if the head gap lever is placed in positions 4 through 9.

An RC circuit is also used to compensate for the fluctuation of drive voltage (+38 vdc).2-1-04B.pcx

2.1.06 Spacing Drive Circuit

The Motor Control LSI (Q9) outputs the SPMO DA signal upon receiving the spacing command from the Slave MPU (Q11). This is a fixed cycle pulse signal.

To control the motor speed, the Motor Control LSI varies the pulse duty cycle according to the speed data from the Slave MPU.

The SPMO FOW or SPMO REV signal from the Head Control LSI (Q8) changes the current direction in the DC motor to run the motor in either the forward or reverse direction.

As the space motor rotates, it generates feedback pulse signals SP Phase A and SP Phase B. The Motor Control LSI detects the edge pulses from these signals and divides the frequency to output the MO LSI IPT signal for use in Dot Timing.

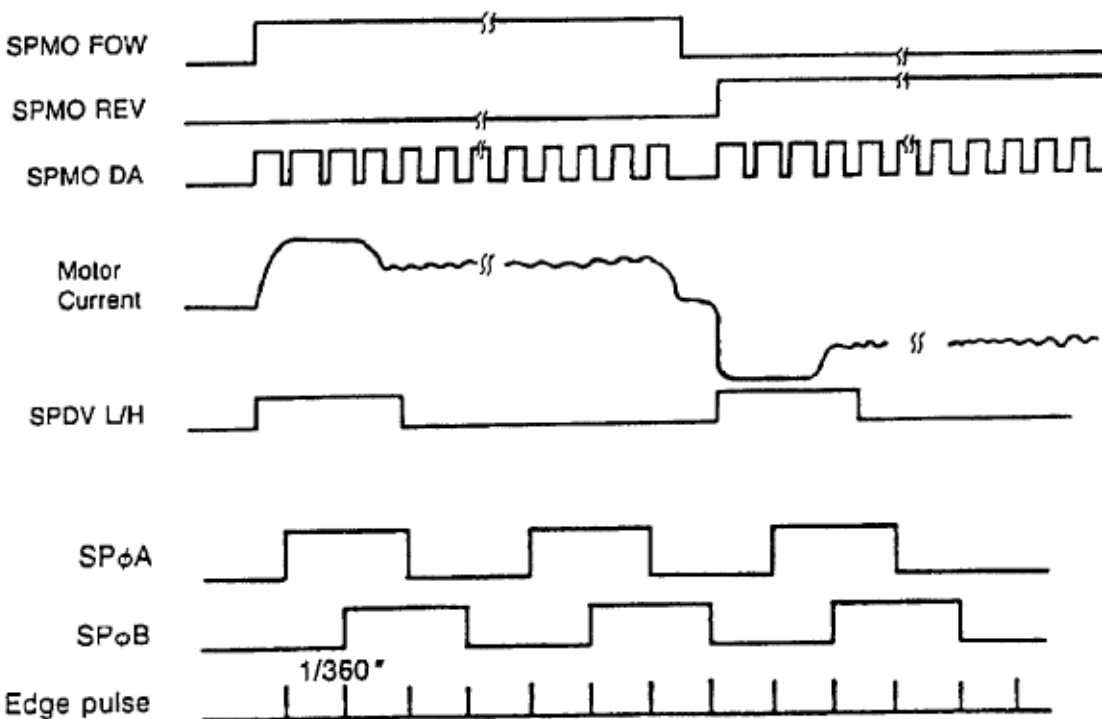



Service Guide ML393/ML393CPlus

Chapter 2 Principles of Operation

2.1.07 Line Feed Circuit

The Line Feed Motor Shaft is held stationary by +8 vdc supplied according to the pulse duty cycle of the LFCHOP signal (the holding current is approximately 30 ma) whenever in a stopped position.

During line feed operation, the Line Feed Motor is driven by +38 vdc in accordance with the LFOVDV-N signal. The signals LF Phase 1 through LF Phase 4 establish the proper phase relationship for driving the motor.

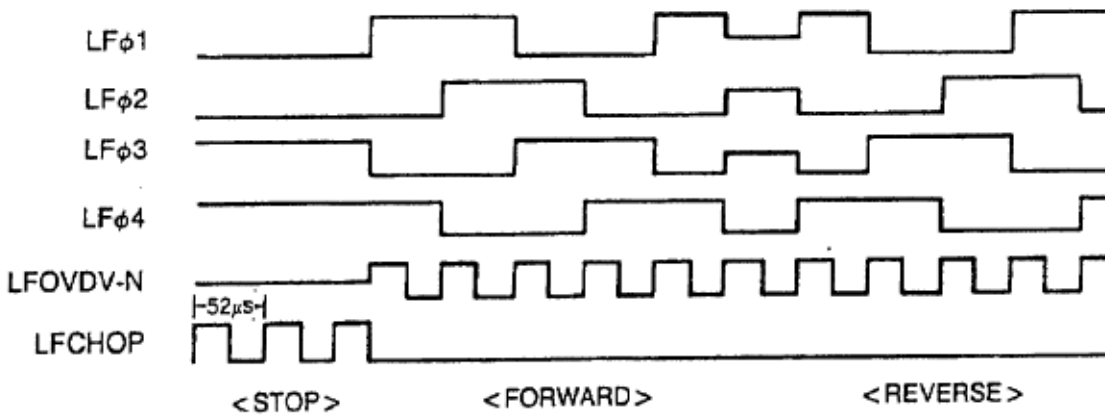

Copyright 1997, Okidata, Division of OKI America, Inc. All rights reserved. See the OKIDATA Business Partner Exchange (BPX) for any updates to this material. (<http://bpx.okidata.com>)



Service Guide ML393/ML393CPlus

Chapter 2 Principles of Operation

2.1.08 Alarm Circuits

Fault Alarm Circuit (in Power Supply Unit)

This protective circuit turns off the Power Supply when a fault occurs in the printhead, line feed, or bail/ribbon motor drive circuits, thus preventing secondary component failure.

To accomplish this, the circuit monitors the overdrive signal of each drive circuit. If the duration of any drive circuit exceeds a predetermined length of time, the appropriate signal (HDE ALM, HDO ALM, LF COM or RBN COM) will be sent to the fault alarm circuit. The fault alarm circuit generates the ALM signal (high) which causes the power supply to turn all DC power OFF.

Printhead Overheat Alarm Circuit

In order to protect the printhead coils, this circuit monitors the printhead temperature by using a thermistor contained in the printhead. The CPU senses this circuit every time a line is printed.

When printing, the printhead temperature rises. If the head temperature reaches approximately 115 to 125 degrees Celsius, a head overheat condition (ALARM 1) is generated.

When ALARM 1 is detected, bi-directional printing stops. Uni-directional printing continues.

If the printhead temperature continues to rise, ALARM 2 is generated. All printing stops.

Printing resumes when the head temperature falls below the ALARM 1 level.

Cover Open Alarm Circuit

When the front access cover is opened, the COVOPEN-N signal is sent to the Slave MPU from the cover interlock microswitch. The Slave MPU relays the switch status to the Master MPU. The Master MPU will halt printing at the completion of the current line and light the ALARM Lamp.



Service Guide ML393/ML393CPlus

Chapter 2 Principles of Operation

2.1.09 Paper End Detection Circuit

Whenever the Release Lever is in the Continuous Feed position, Paper End is detected by the microswitch on the Push Tractor (rear feed) or the Paper End sensor on the sensor board (bottom feed).

Whenever the Release Lever is in the Sheet Feed position, Paper End is detected by a photosensor located in the paper pressure guide.

When the printer detects an out of paper condition, the PE-N signal goes low. Printing stops. The ALARM LAMP is turned ON.

Copyright 1997, Okidata, Division of OKI America, Inc. All rights reserved. See the OKIDATA Business Partner Exchange (BPX) for any updates to this material. (<http://bpx.okidata.com>)

2.1.10 Power Supply

This switching power supply converts the AC input voltage to +5 vdc, +/-8 vdc and +38 vdc for use throughout the printer.

Voltage / Signal Table

Voltage/Signal	Purpose
+5 vdc	IC Logic Levels - LED Drive Voltage
+8 vdc	Serial Interface Logic Levels - Line Feed Motor Locking Voltage
-8 vdc	Serial Interface Logic Levels
+38 vdc	Printhead Space Motor Line Feed Motor Bail/Ribbon Motor Drive Voltage
POW ALM	This signal is sent by the Power Supply in the event of an abnormal temperature rise in the power supply unit or an overcurrent condition of the +38 vdc. The Main Control Board suppresses this condition by temporarily suspending printing. If the condition does not change the Main Control Board will enable the FAN ALARM (Alarm 60) Refer to Section 4 of this Service Handbook.
ALM	This signal is sent by the Main Control Board when an of an overdrive condition is detected in either the printhead line feed motor or bail/ribbon motor drive circuits. The power supply disables the + 38 vdc output when this signal is detected.

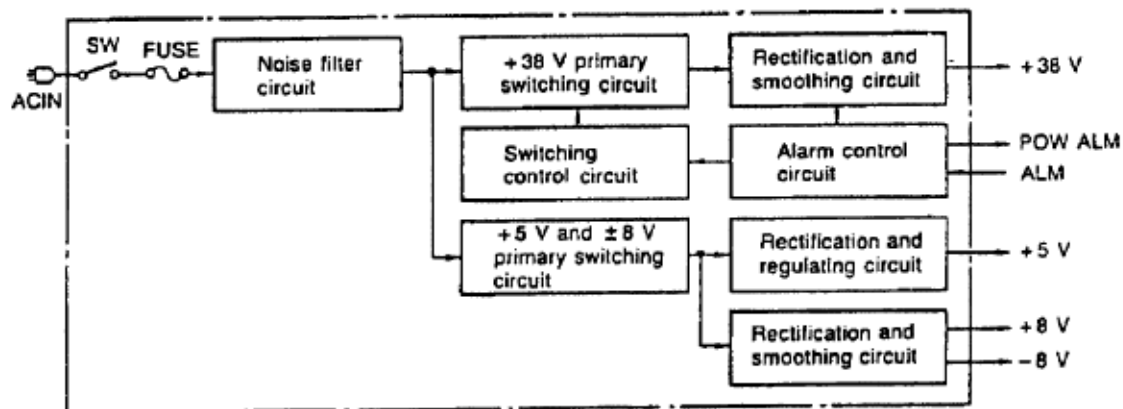

Copyright 1997, Okidata, Division of OKI America, Inc. All rights reserved. See the OKIDATA Business Partner Exchange (BPX) for any updates to this material. (<http://bpx.okidata.com>)



Service Guide ML393/ML393CPlus

Chapter 2 Principles of Operation

2.2 MECHANICAL OPERATION

2.2.01 Printhead Mechanism

The printer uses a highly efficient stored energy type printhead. Power is not consumed until the printwires are activated. This extends printhead life to approximately 200 million characters.

The printhead uses 24 printwires (two columns of 12 wires each). Each wire is welded to an armature. Behind this armature is a spacer ring.

Each of the 24 printwire armatures have a permanent magnet behind them. The magnets attract the armatures, drawing the printwires into the wire guide. This keeps the wires inside the printhead. A coil is wrapped around each of the permanent magnets.

When a dot is to be printed, current passes through the appropriate coil. This creates an electromagnetic field which opposes the magnetic field of the permanent magnet. The armature springs forward. The print wire (which is attached to the armature) strikes the ribbon and prints a dot on the paper.

When current is removed from the coil, the magnetic field of the permanent magnet attracts the armature, retracting the printwire into the wire guide.

The printhead contains a built-in thermistor used to monitor the printhead temperature.

The parts listed below make up the printhead.

- Wire Guide
- Print Wires
- Armature Assembly
- Spacer
- Permanent Magnet Assembly
- Thermistor
- Printed Circuit Board with Coils

Head Gap Adjusting

The head gap adjusting mechanism adjusts the gap between the platen and printhead.

Move the adjusting lever on the left side of the printer mechanism to change the head gap.

When the lever is moved, the carriage shaft rotates. The carriage shaft is attached to the printer mechanism with eccentric collars. As the carriage shaft rotates, the distance between the platen and carriage shaft changes.

Two items factor into printhead gap information.

1. Printhead Gap Adjustment

This is a SERVICE ADJUSTMENT made by a technician.

It is covered in Section 3.3  of this Service Handbook.

The Adjustment measures 0.017, +/- 0.001 inches (0.43, +/- 0.03 mm).

2. Printhead Gap Adjust

This is a manual adjustment performed by the end-user.

It is performed by moving the blue head gap lever, located on the right side of the printer.

The settings are 1, 2, 3, 4, 5, 6, 7, 8, 9

1 is the smallest (narrowest) gap.

9 is the largest (widest) gap.

Setting	Paper Type
1	12 - 15 lb. paper
2	20 - 24 lb. paper
3 - 4	Labels
3 - 4	Two-part forms
4 - 5	Three-part forms
7	Four-part forms
5 - 9	Envelopes

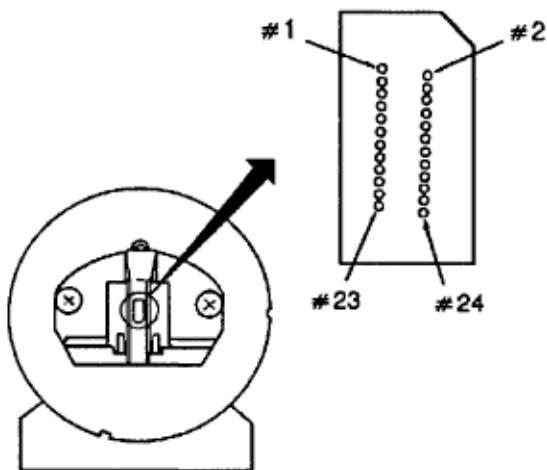

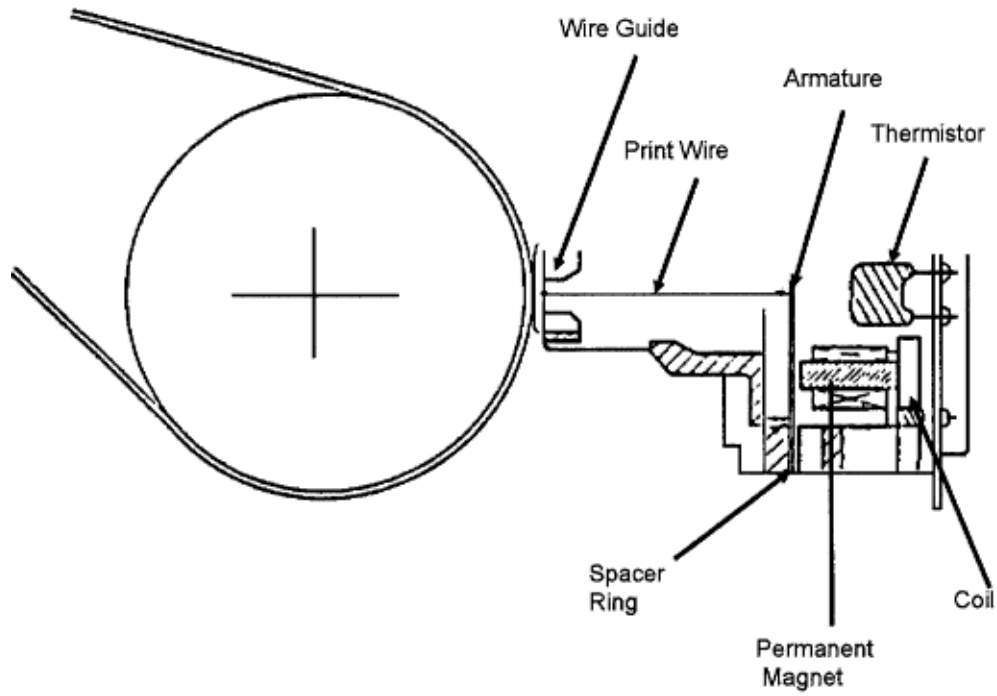

Copyright 1997, Okidata, Division of OKI America, Inc. All rights reserved. See the OKIDATA Business Partner Exchange (BPX) for any updates to this material. (<http://bpx.okidata.com>)

2.2.02 Spacing

Spacing is performed when the space motor drives the carriage along the carriage shaft, parallel to the platen. The spacing mechanism consists of the items listed below.

Space Motor

Drive Pulley

Idle Pulley

Carriage Shaft

Carriage Frame

Space Belt

Spacing Operation

The carriage containing the printhead moves parallel to the platen along the main carriage shaft. Power from the space motor is transferred via the space belt, which is attached to the bottom of the carriage frame. The carriage is designed to move 0.8 inches when the servo motor performs one rotation.

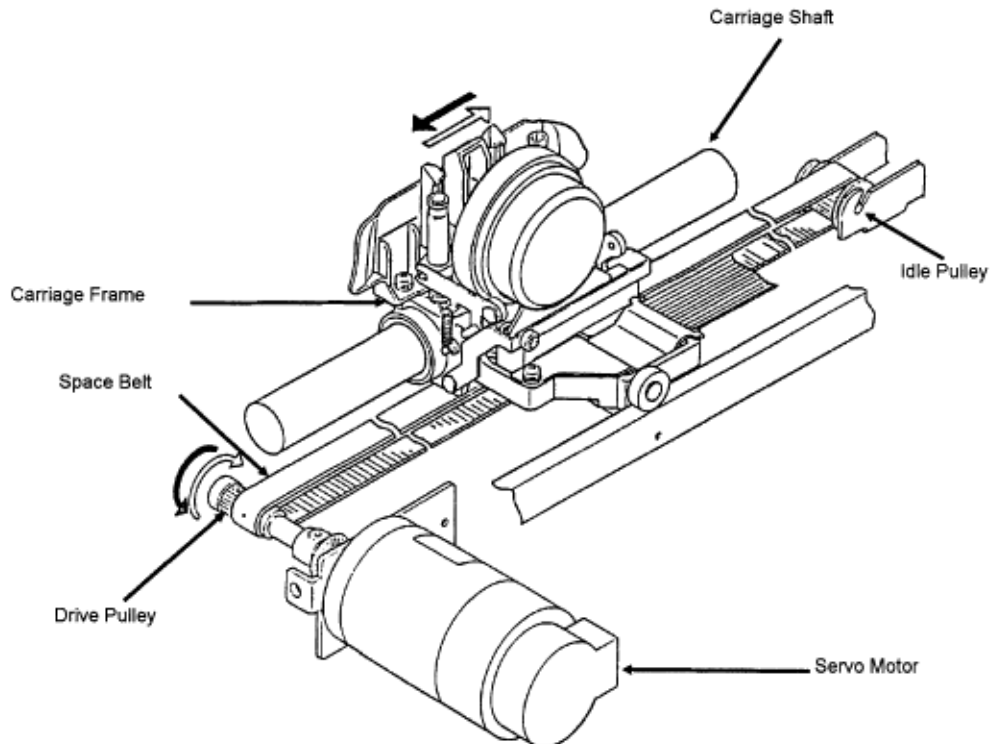

Copyright 1997, Okidata, Division of OKI America, Inc. All rights reserved. See the OKIDATA Business Partner Exchange (BPX) for any updates to this material. (<http://bpx.okidata.com>)

2.2.03 Ribbon Drive

The ribbon drive mechanism moves the ribbon in synchronization with the space motor operation.

The ribbon drive mechanism consists of the items listed below.

Ribbon Drive Assembly

Ribbon Cartridge

Ribbon Cartridge

An endless ribbon with a single direction feed is used. Ink is supplied from an ink tank, which is built-in to the ribbon cartridge.

Ribbon Feed Operation

The rotation of the space motor is transmitted to the drive gear in the ribbon cartridge through the ribbon feed gear assembly. This feeds the ink ribbon.

The feed direction of the ribbon is maintained by switching the rotational direction of the gears in the ribbon drive assembly. This ensures uni-directional ribbon movement when bi-directional printing is used.

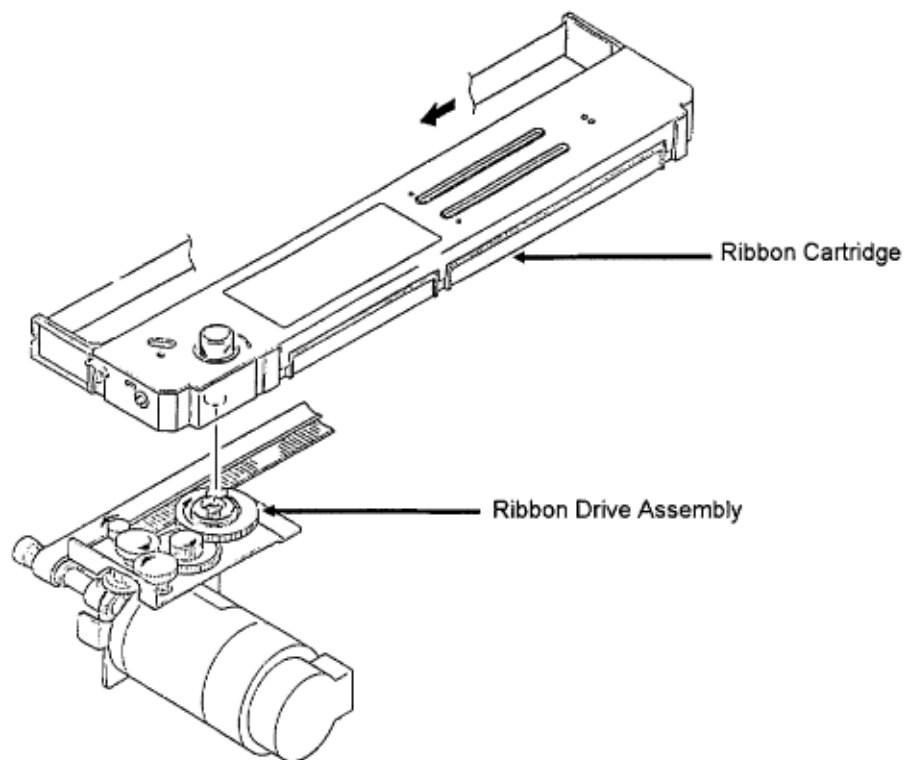

Copyright 1997, Okidata, Division of OKI America, Inc. All rights reserved. See the OKIDATA Business Partner Exchange (BPX) for any updates to this material. (<http://bpx.okidata.com>)

2.2.04 Paper Feed

Paper feeding is performed by turning the platen and the pin tractor, which is driven by the line feed pulse motor.

The paper feed mechanism consists of the items listed below.

Pulse Motor (with gears)

Idler Gear

Change Spring

Change Gear

Platen

Tractor Feed Unit

Paper Pressure Guide

Friction Feed

When the release lever is set to the SHEET FEED position, the change gear is disengaged from the tractor gear. At the same time, the release lever applies pressure to push the pressure rollers against the platen, allowing paper to be fed.

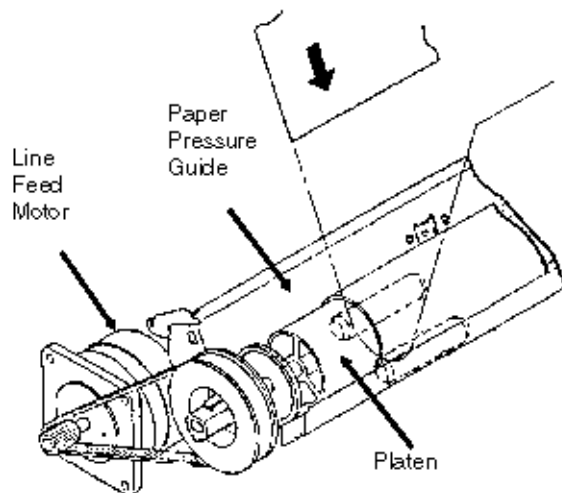

Tractor Feed

When the release lever is set to the TRACTOR FEED position, the release lever allows the reset spring to push the change gear toward the tractor gear. At the same time, the release lever pushes the pressure rollers away from the platen, allowing paper to be fed by the tractors.

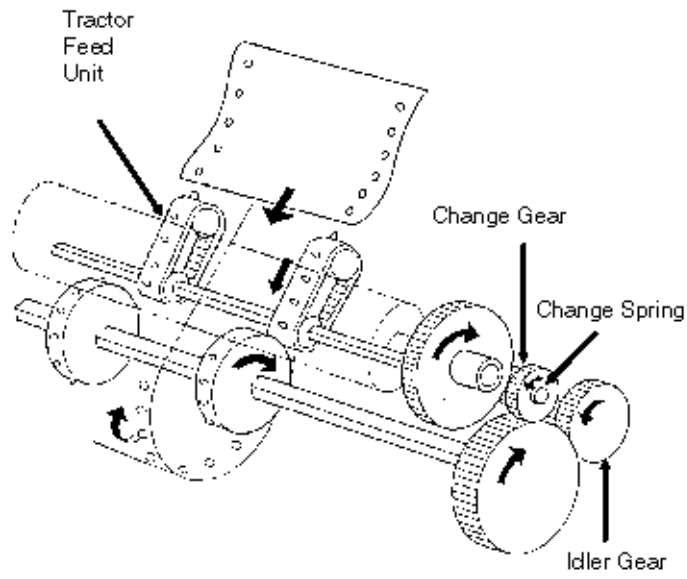

Copyright 1997, Okidata, Division of OKI America, Inc. All rights reserved. See the OKIDATA Business Partner Exchange (BPX) for any updates to this material. (<http://bpx.okidata.com>)

2.2.05 Paper-End Detection

Cut-Sheet Paper-End

When the release lever is in the SHEET FEED position, the photosensor located in the paper pressure guide is active. If sheet paper is installed, the paper is detected by the sensor and the sensor is activated (ON). When the printer is out of sheet paper, the sensor is deactivated (OFF), indicating a paper-end condition.

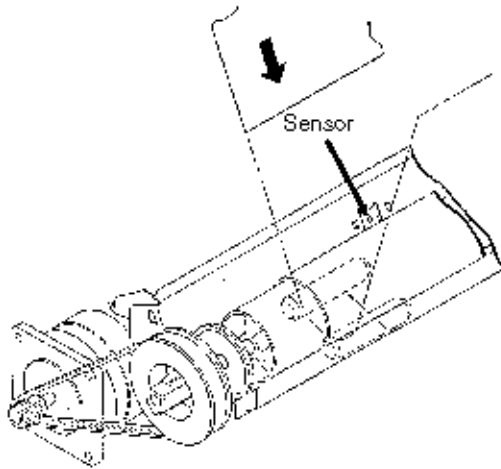

Bottom Feed Paper-End

This is used with optional Pull Tractor.

When the release lever is in the TRACTOR FEED position, the switch on the left push tractor and the paper-end sensor on the sensor board are active. If paper is detected by either of these sensors, paper-end is inhibited.

When bottom feed paper is installed, it moves the bottom paper-end lever to turn the sensor ON. When a paper out condition exists, the lever blocks the sensor, indicating a paper-end condition.

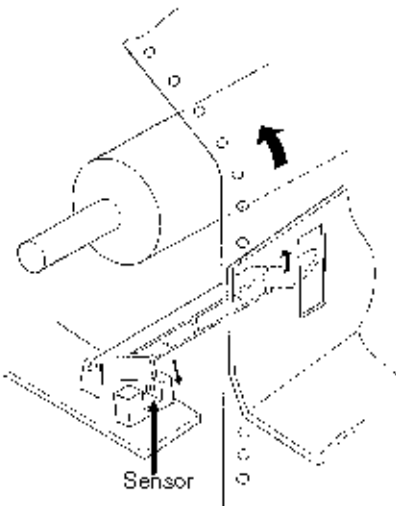

Rear Feed Paper-End

When the release lever is in the TRACTOR FEED position, the switch on the left push tractor and the paper-end sensor on the sensor board are active. If paper is detected by either of these sensors, paper-end is inhibited.

When rear feed paper is installed, pressure is placed on the microswitch, located in the left push tractor. Since the switch is turned ON, paper is detected.

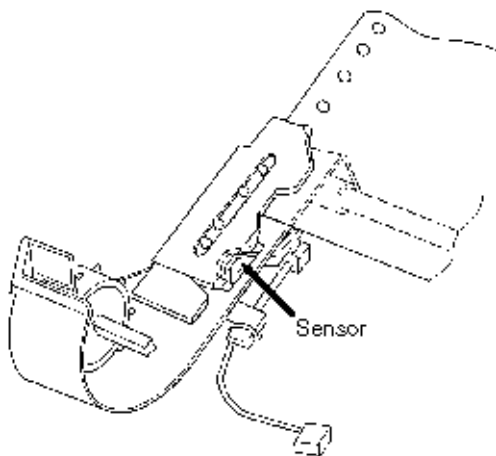



Service Guide ML393/ML393CPlus

Chapter 2 Principles of Operation

2.2.06 Paper Park

General Information

Paper park allows the user to switch from continuous feed paper to single-sheet paper without removing the continuous feed paper from the printer. The continuous feed paper will be retracted from the platen and down into the printer housing without disengaging it from the built-in tractor.

After a single-sheet paper is printed, pull the bail lever forward and the continuous feed paper will move back into the print position.

Paper park cannot be used when the optional pull tractor is installed.

The operation of the Paper Park feature is listed below.

Press PARK/TOF.

Reverse line feed retracts the paper until a paper-end condition exists or until 14 inches of paper has been retracted. The paper will remain on the push tractor, but out of the printing path.

Procedure: Continuous Feed to Single Sheet

1. Tear off any printed pages.
2. Make sure the printer is selected. The SELECT lamp must be lit.
3. Press PARK / TOF.
4. The paper will retract from the paper path.
5. Move the paper selection to the single sheet position (towards the back of the printer).
6. Raise the paper support to its upright position.
7. Align the left paper guide with the paper icon on the support.
8. Place a piece of paper in the paper support.
9. Position the right paper guide to accommodate the right edge of paper.
10. Press FORM FEED to feed single-sheet paper into the printer.
11. Print the single sheet.

Procedure: Single Sheet to Continuous Feed

1. Remove any single-sheet paper in the printer.
 2. Move the paper selection lever to the continuous form position (to the front of the printer).
 3. Lower the paper support.
 4. Press FORM FEED to feed continuous feed paper into the printer.
 5. The paper will advance to the loading position.
 6. Adjust the top of form (if necessary).
-

Copyright 1997, Okidata, Division of OKI America, Inc. All rights reserved. See the OKIDATA Business Partner Exchange (BPX) for any updates to this material. (<http://bpx.okidata.com>)



Service Guide ML393/ML393CPlus

Chapter 2 Principles of Operation

2.2.07 Automatic Paper Loading

Automatic Paper Loading is used to consistently set the print start position when using cut-sheet or continuous sheet paper. The procedure is listed below.

Cut-Sheet Paper

1. Push the Paper Release Lever to the Cut-Sheet position.
2. Insert the paper from behind the platen.
3. Press the FORM FEED switch.
4. The Paper Bail will automatically open.
5. The Line Feed operation will load the paper.
6. The Paper Bail will automatically close.

NOTE:

If the paper does not move, the Auto-Load motion becomes invalid and is treated like an ordinary paper-end.

Continuous Sheet (Rear Feed) SASF

1. Push the Paper Release Lever to the Continuous Sheet side (front of printer).
2. Insert the paper into the push tractor. DO NOT allow the front edge of the paper to extend beyond the white line of the left tractor assembly. The white guide line MUST BE visible.
3. Press the FORM FEED switch.
4. The Paper Bail will automatically open.
5. The Line Feed operation will load the paper.
6. The Paper Bail will automatically close.

NOTE:

If the paper does not advance after the line feed motor has fed the equivalent of 2.4 inches of paper, the Auto-Load process stops. This situation is treated like an ordinary paper-end condition.

3.1 MAINTENANCE

3.1.01 General Information

This section lists the parts replacement, adjustment, cleaning, lubrication, and shipping procedures.

Disassembly should not be performed unless absolutely necessary. **NEVER** perform disassembly on a malfunctioning unit until you have followed the failure analysis procedures in Section Four of this Service Handbook.

Follow the procedures listed in *Adjustments and Service Settings*. Adjustments may be required when either consumables or parts are replaced. Failure to perform these procedures could result in unnecessary service calls.

Cleaning procedures must be performed correctly if high print quality is to be achieved.

3.1.02 Maintenance Items

The following items are required to service the unit.

Disassembly / Adjustments

#1 Phillips Screwdriver (with magnetic tip)

#2 Phillips Screwdriver (with magnetic tip)

#3 Phillips Screwdriver (with magnetic tip)

Straight-slot Screwdriver

Needle Nose Pliers (4 inch)

Diagonal Cutters

Tension Gauge (capable of measuring 1 pound of pressure)

7 mm open-ended wrench

Ruler (capable of measuring 1/16 inch increments)

3/32 inch socket with driver

Feeler Gauge

Digital Multimeter

Cleaning / Lubrication

Shop Vacuum

Cloth (soft and lint-free)

All-Purpose Cleaner

Platen Cleaner

Contact Kleen (Okidata P/N 51802301)

Machine Grease

Machine Oil

3.1.03 Maintenance Precautions

1. Do not disassemble the unit if it is operating normally.
2. Before starting disassembly and assembly, always power OFF the unit and detach the AC power cord.
3. Detach the interface cable, if installed.
4. Do not remove parts unnecessarily. Try to keep disassembly to a minimum.
5. Use the recommended maintenance tools.
6. When disassembling, follow the listed sequence. Failure to follow the correct sequence may result in damaged parts.
7. Since screws, collars and other small parts are easily lost, they should be temporarily attached to the original positions.
8. Use extreme care when handling circuit boards. Integrated circuits (microprocessors, ROM, and RAM) can be destroyed by static electricity.
9. Do not place printed circuit boards directly on conductive surfaces.
10. Follow the recommended procedures when replacing assemblies and units.
11. When replacing the main control board, be sure to remove any socketed PROMS and EEPROMS.

Replacement printed circuit boards are shipped WITHOUT these items.

When removing PROMs and EEPROMs, you MUST follow standard Electrostatic Sensitive Device (ESD) safety precautions or you may damage the components.

12. Perform the line feed belt tension adjustment when any of the following occur.

Erratic line spacing occurs

Parts are replaced

[Line Feed Belt \(3.2.09 !\[\]\(e1d6102fe77919492c04879c8450f1f5_img.jpg\)\).](#)

13. Perform the color adjustment when any of the following occur.

Colors "bleed" into one another

Parts are replaced

[Ribbon Shift Cam and Ribbon Shift Gear \(3.2.27 !\[\]\(ab4e2b3fc7e7887b7a72f548aa6f5e60_img.jpg\)\).](#)

[Ribbon Shift Cam Lever Assembly \(3.2.28 !\[\]\(104fbf564e2e5a8fbd84f31656d114c7_img.jpg\)\).](#)

[14. Perform the printhead gap adjustment procedure \(Refer to Section 3.3 of this Service Handbook !\[\]\(aab88c0d099e5d18d6533a97b13ec28d_img.jpg\) \) when any of the following occur.](#)

Poor Print Quality

Uneven Print Quality (darker on one side of the document).

Excessive wear on the printhead or platen

Parts are replaced

[Printhead \(3.2.01 !\[\]\(f9f168a9979beed8b01f8750d577d508_img.jpg\)\).](#)

[Platen Assembly \(3.2.09 !\[\]\(111c5272ee3f91361f0d2e3665dd6ad0_img.jpg\)\).](#)

[Space Motor Assembly \(3.2.14 !\[\]\(6befd466863f06afb75445d91429f055_img.jpg\)\).](#)

Carriage Shaft (3.2.18)

Copyright 1997, Okidata, Division of OKI America, Inc. All rights reserved. See the OKIDATA Business Partner Exchange (BPX) for any updates to this material. (<http://bpx.okidata.com>)



Service Guide ML393/ML393CPlus

Chapter 3 Maintenance

3.2 DISASSEMBLY/ASSEMBLY PROCEDURES

General Information

This section contains the printer disassembly procedures. Only the removal procedures are explained here. Reverse the procedure for the installation.

At the bottom of each procedure is a listing of the parts covered in that procedure. The Okidata part number, item description, comment (RSPL, Option, Consumable) and cross-reference to Appendix B is provided for each part. Items included in the Recommended Spare Parts List are indicated by the acronym RSPL. N/A will appear where a part number is not available.

Part Item Comment Appendix B Number Description Reference

This Service Handbook lists the disassembly procedures for major components of the unit. Okidata DOES NOT recommend disassembling a unit which is operating normally. If you decide to perform disassembly during this training, Okidata recommends that you perform *only* the disassembly procedures for RSPL items. All other procedures are provided to assist you in identifying parts. It is not likely that you will perform these procedures while servicing the unit.

Be sure to read all notes, cautions, and warnings, as they contain important information regarding disassembly / assembly.

Microline 393C-Plus Only (Color Version)

[3.2.23 Ribbon Shift Arm and Shift Arm Spring](#)

[3.2.24 Roller Lever](#)

[3.2.25 Ribbon Guide](#)

[3.2.26 Bail Open Cam and Bail Open Gear](#)

[3.2.27 Ribbon Shift Cam and Ribbon Shift Gear](#)

[3.2.28 Ribbon Shift Cam Lever Assembly](#)

Cut Sheet Feeder - Option

[3.2.29 Friction Sheet](#)

[3.2.30 Rear Bin](#)

[3.2.31 Side Cover](#)

[3.2.32 Roller Supports and Rollers \(H\)](#)

[3.2.33 Control Board](#)

[3.2.34 Connection Cord](#)

[3.2.35 Motor Assembly](#)

Partner Exchange (BPX) for any updates to this material. (<http://bpx.okidata.com>)

3.2.01 Preliminary Items, Printhead

WARNING:

The printhead will be HOT immediately after printing.

1. Power OFF the printer and detach the AC power cord (1).
2. Detach the interface cable, if installed. [*Not Shown*]
3. Open the printer access cover.
4. Remove the ribbon cartridge (2).
5. Place the head gap adjusting lever (3) to the range 9 position.
6. Remove the two mounting screws (4).
7. Lift the printhead (5) from the connector to remove it.

NOTE: *When installing the printhead, pull the printhead towards the stopper (in the direction of Arrow A). Perform the printhead gap adjustment after installation. Refer to Section 3.3 of this Service Handbook for further information.*

[P/N 56609701 Cord: AC Power \(120 vac\) RSPL B.2.03](#) 

[P/N 56624101 Cable: AC 220V \(ML\) Right Ang RSPL B.2.03](#) 

[P/N 70000803 Kit: Parallel Interface Plug n Play Option B.2.14](#)  **[Accessory \(Cable\)](#)**

[P/N 70012801 Kit: RS232-C Serial Interface Cable Option B.2.14](#) 

[P/N 52103801 Cartridge: Film Ribbon \(Black\) Consumable B.2.04](#)  **[B.2.17](#)** 

[P/N 52103601 Cartridge: Ribbon \(Black\) Consumable B.2.04](#)  **[B.2.17](#)** 

[P/N 52103701 Cartridge: Ribbon \(Color\) Consumable B.2.04](#)  **[B.2.17](#)** 

[P/N 50054202 Printhead: \(Mylar Comp\) RSPL B.2.03](#) 

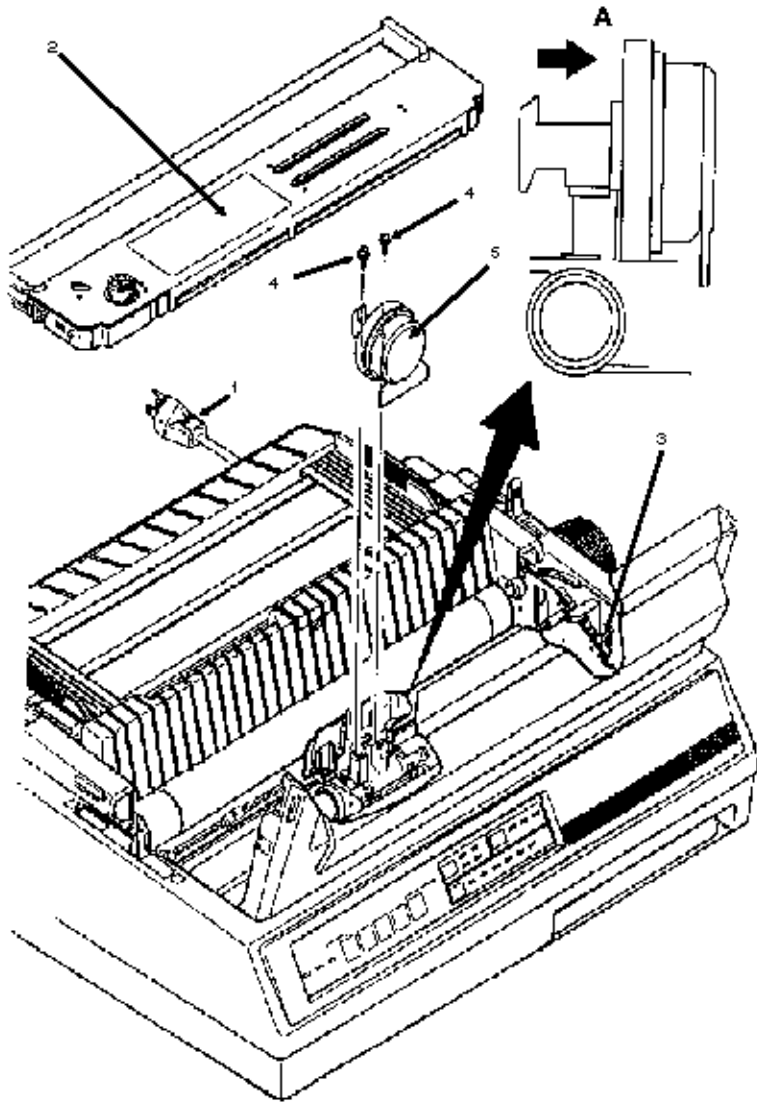

Copyright 1997, Okidata, Division of OKI America, Inc. All rights reserved. See the OKIDATA Business Partner Exchange (BPX) for any updates to this material. (<http://bpx.okidata.com>)



3.2.02 Ribbon Guide

1. Remove the printhead ([3.2.01](#) ).
2. Remove the two mounting screws (1).
3. Lift the ribbon guide (2) and remove it.

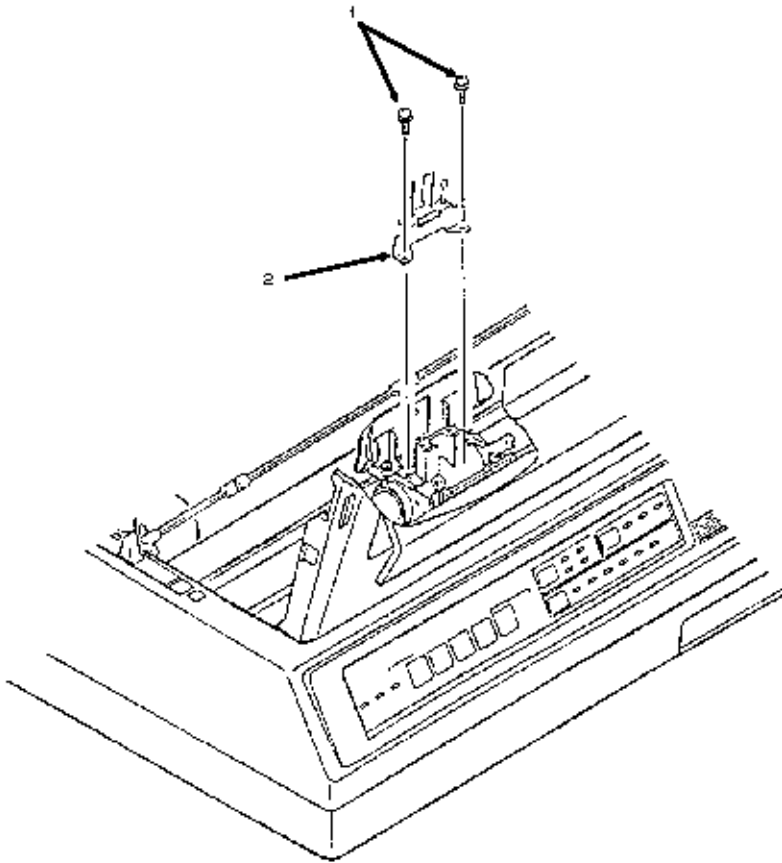
[P/N 53055901 Guide: Ribbon \(Black\) RSPL B.2.12](#) 



3.2.03 Ribbon Protector

1. Remove the printhead (3.2.01 )
2. Remove the ribbon guide (3.2.02 )
3. Remove the two mounting screws (1).
4. Lift the ribbon protector (2) and remove it.

P/N 53527001 Protector: Ribbon RSPL B.2.12  , B.2.13 

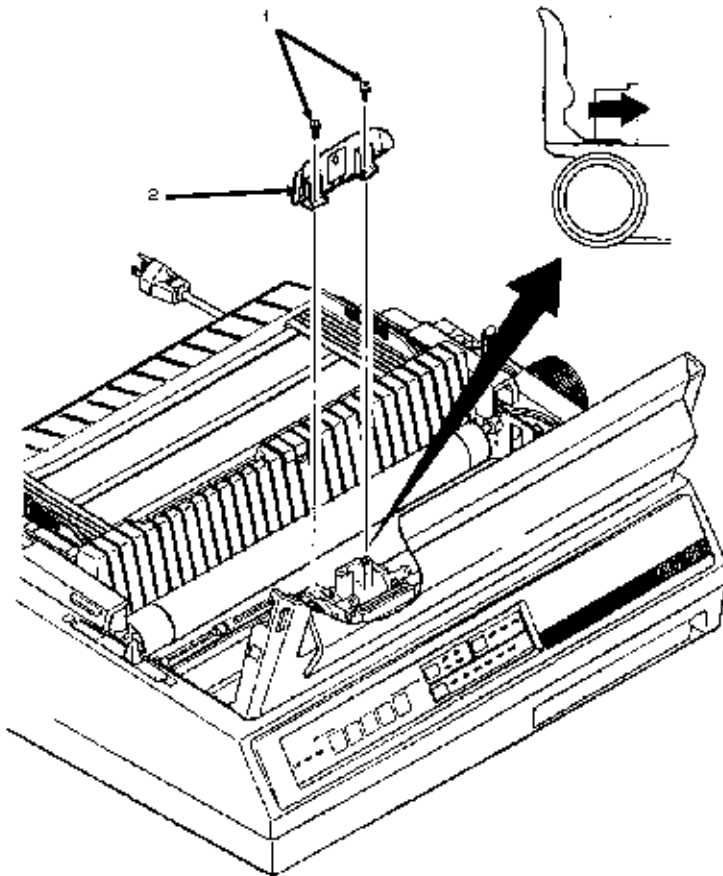

3.2.04 Upper Cover Assembly

Procedure

1. Disconnect the interface cable (1).
2. Remove the font cartridge or buffer expansion cartridge (2) if installed.
3. Detach the two platen knobs (3).
4. Remove the two cover mounting screws (4) at the rear of the printer.
5. Lift the rear access cover (5) to the open position.
6. Lift the upper cover assembly at the back and tilt it towards the front to remove it.

NOTES:

When installing the upper cover assembly, perform the actions listed below.

Move the release lever (6) towards the front of the printer.

Move the bail arm lever (7) towards the back of the printer.

Check that the paper bail moves properly.

When cleaning, refer to Section 3.4 of this Service Handbook. 

The upper cover assembly includes the middle cover, the access cover, the rear cover, the bail lever, the paper separator, and the sheet insertion guide. Refer to Appendix B of this Service Handbook for details.

The parts list appears on the following pages.

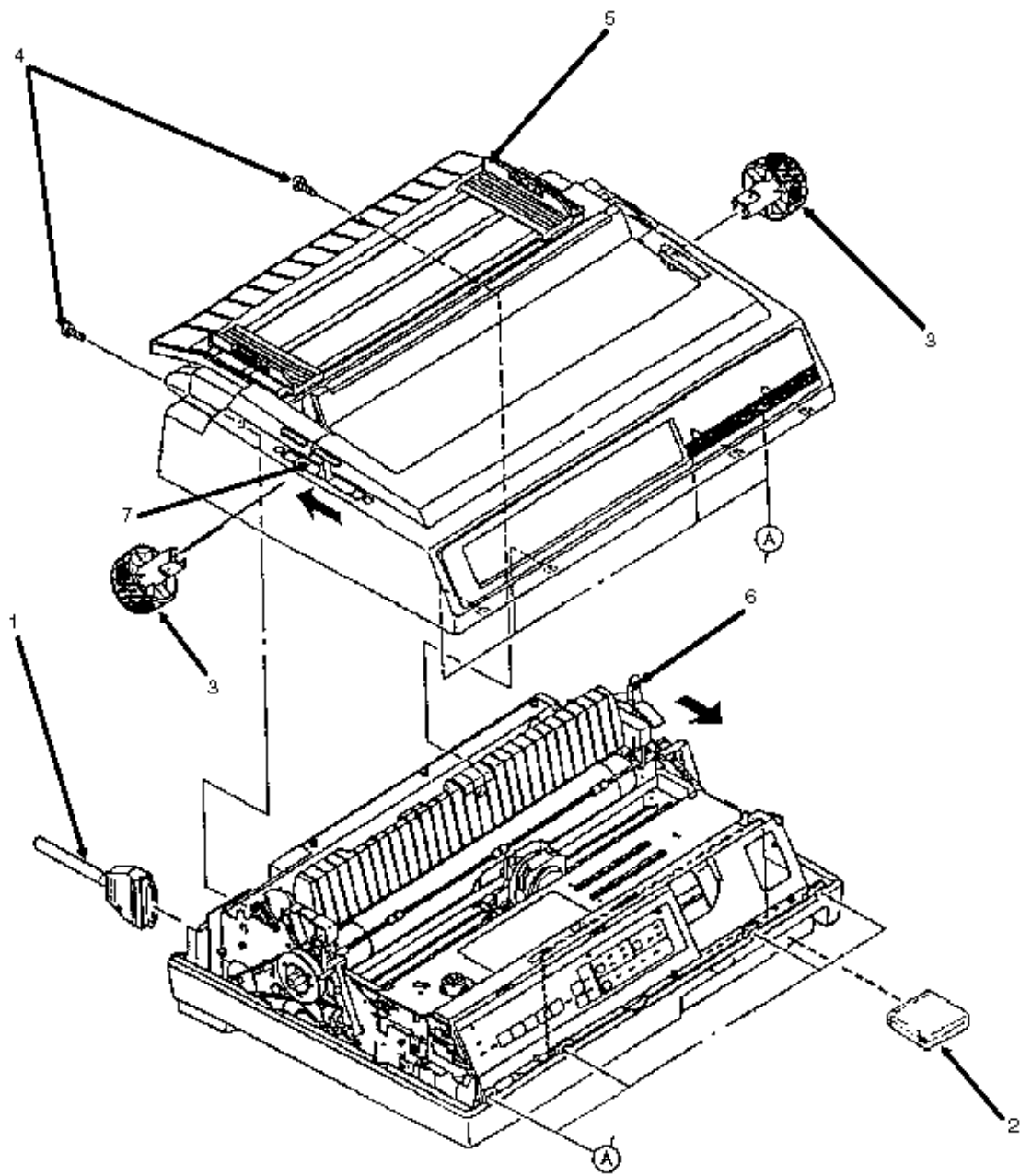

Copyright 1997, Okidata, Division of OKI America, Inc. All rights reserved. See the OKIDATA Business Partner Exchange (BPX) for any updates to this material. (<http://bpx.okidata.com>)

Parts List

[P/N 7000803 Kit: Parallel Interface Plug n Play Option B.2.14 Accessory \(Cable\)](#) 

[P/N 70012801 Kit: RS232-C Serial Interface Cable Option B.2.14](#) 

[P/N 70010201 Gothic Font Cartridge Option B.2.03](#)  , [B.2.14](#) 

[P/N 70010101 Prestige Font Cartridge Option B.2.03](#)  , [B.2.14](#) 

[P/N 70016401 Cartridge: 32 Kbyte RAM Expansion Option B.2.03](#)  , [B.2.14](#) 

[P/N 53478601 Knob: Platen RSPL B.2.03](#) 

[P/N 50212427 Cover: Middle \(ML393+\) RSPL B.2.02](#) 

[P/N 50212426 Cover: Middle \(ML393C+\) RSPL B.2.02](#) 

[P/N 50212306 Cover: Access \(Monochrome\) RSPL B.2.02](#) 

[P/N 50212307 Cover: Access \(Color\) RSPL B.2.02](#) 

[P/N 50212504 Cover: Rear RSPL B.2.02](#) 

[P/N 53482901 Lever: Bail B.2.02](#)  , [B.2.04](#) 

[P/N 51001901 Separator: Paper B.2.02](#) 

[P/N 53482801 Guide: Sheet Insertion B.2.02](#) 

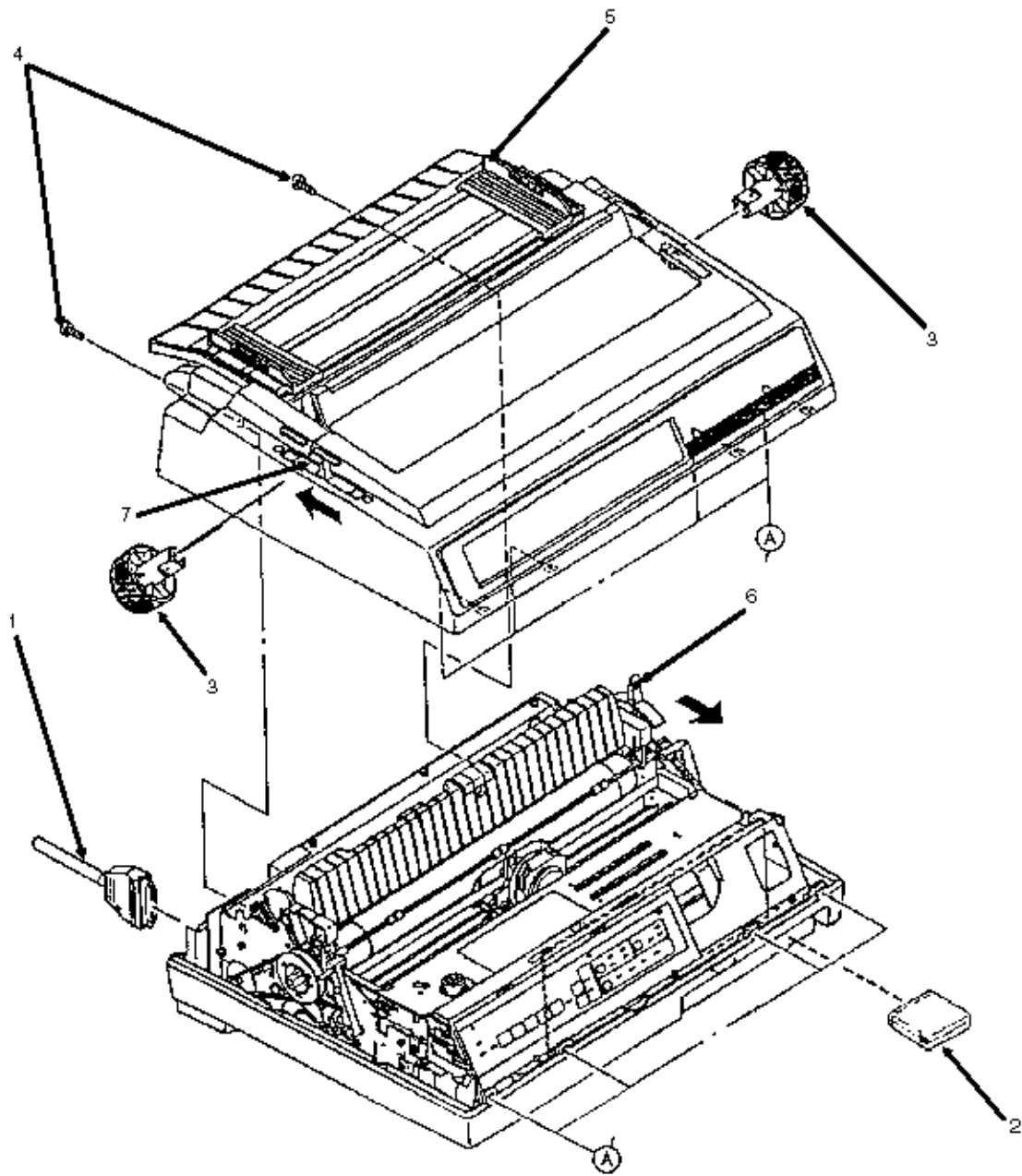

Copyright 1997, Okidata, Division of OKI America, Inc. All rights reserved. See the OKIDATA Business Partner Exchange (BPX) for any updates to this material. (<http://bpx.okidata.com>)

3.2.05 Operator Panel Assembly

1. Remove the upper cover assembly ([3.2.04](#) ).
2. Disconnect the operator panel cable (1) from CN10 (2) on the control board.
3. Remove the two mounting screws (3).
4. Detach the operator panel holder (4) by moving it upward, and then pulling toward the front of the printer.
5. Remove the three mounting screws (5).
6. Open the eleven claws and detach the operator panel (6) from the operator panel holder.

[P/N 55050601 PCB: Operator Panel \(LQSX\) RSPL B.2.05](#) 

[P/N 53479103 Panel: Operator RSPL B.2.05](#) 

[P/N 56614608 Cable: Operator Panel RSPL B.2.05](#) 

[P/N 50910505 Spring: Cover Open RSPL B.2.05](#) 

[P/N 56614301 Cable: Microswitch \(Cover Open\) RSPL B.2.05](#) 

[P/N 53535301 Lever: Cover Open B.2.05](#) 

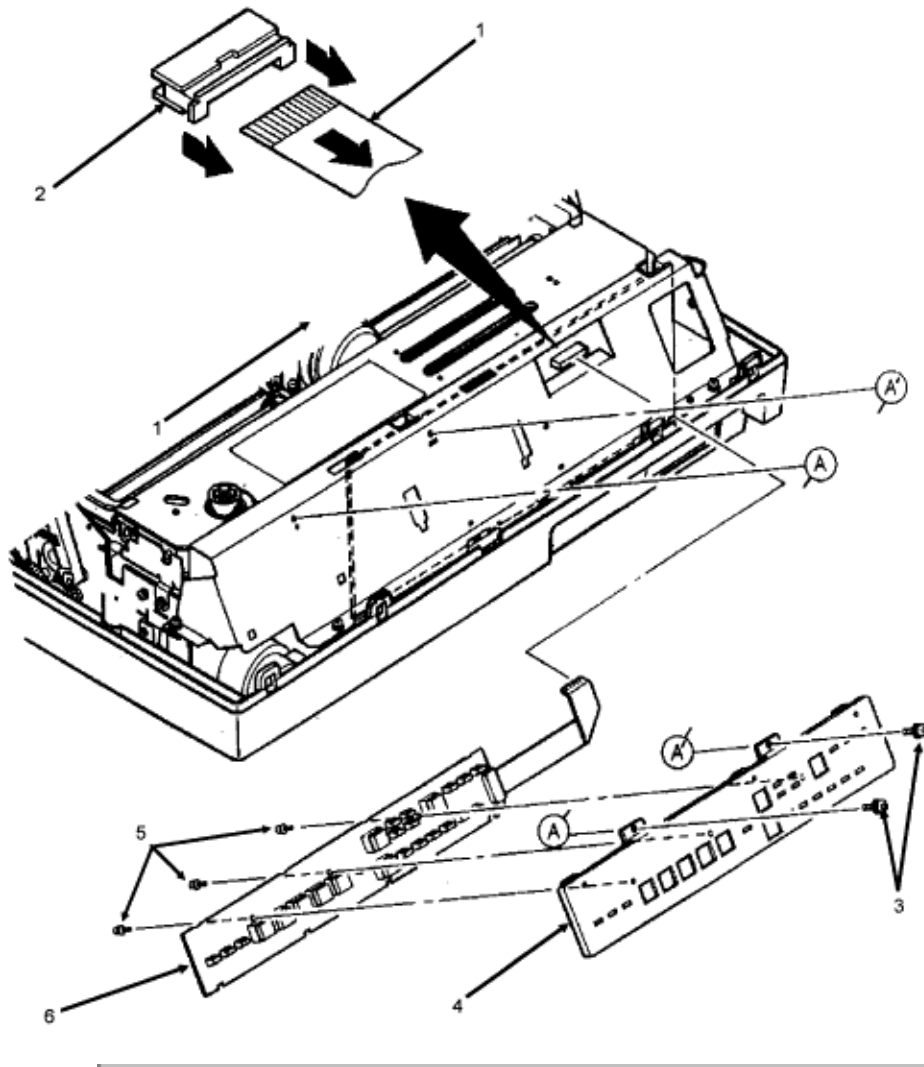

Copyright 1997, Okidata, Division of OKI America, Inc. All rights reserved. See the OKIDATA Business Partner Exchange (BPX) for any updates to this material. (<http://bpx.okidata.com>)



Service Guide ML393/ML393CPlus

Chapter 3 Maintenance

3.2.06 Control Board (LQEM)

1. Remove the upper cover assembly ([3.2.04](#) ) .
2. Remove the ribbon cartridge.
3. Release the lock of connector CN10 (1) and detach the operator panel cable (2).
4. Remove the five shield cover mounting screws (3).
5. While slightly lifting the shield cover (4), detach connector CN13 (5) from the control board (6), then remove the shield cover.
6. Detach the remaining connectors from the control board.
7. Loosen the mounting screw and remove the control board.

NOTES:

Installation

Do not allow cables to get caught under the control board.

Insert the control board into the groove in the base tray (7).

Place the board into the groove (8) in the shield cover, then attach the shield cover.

When replacing the main control board, be sure to remove any socketed PROMS and EEPROMS. Replacement printed circuit boards are shipped WITHOUT these items.

This board has a 2.0 Amp, 125V fuse.

If SP1 is OPEN, an Internal ROM is present. If SP1 is SHORTED - External ROM

SP3 must be OPEN for a Monochrome Model. It must be SHORTED for a Color Model.

CAUTION:

When removing PROMs and EEPROMs, you MUST follow standard Electrostatic Sensitive Device (ESD) safety precautions or you may damage the components.

[P/N 55050411 PCB: Main \(LQEM-1\) Black RSPL B.2.03](#) 

[P/N 55050412 PCB: Main \(LQEM-2\) Color RSPL B.2.04](#) 

[P/N 56619201 Cord: I/F Main PCB Connection \(50 Pin\) RSPL B.2.03](#) 

[P/N 55938501 IC: EEPROM BR93CS46-2-NW RSPL B.2.04](#) 

[P/N 56301703 Fuse: 2A, 125V B.2.04](#) 

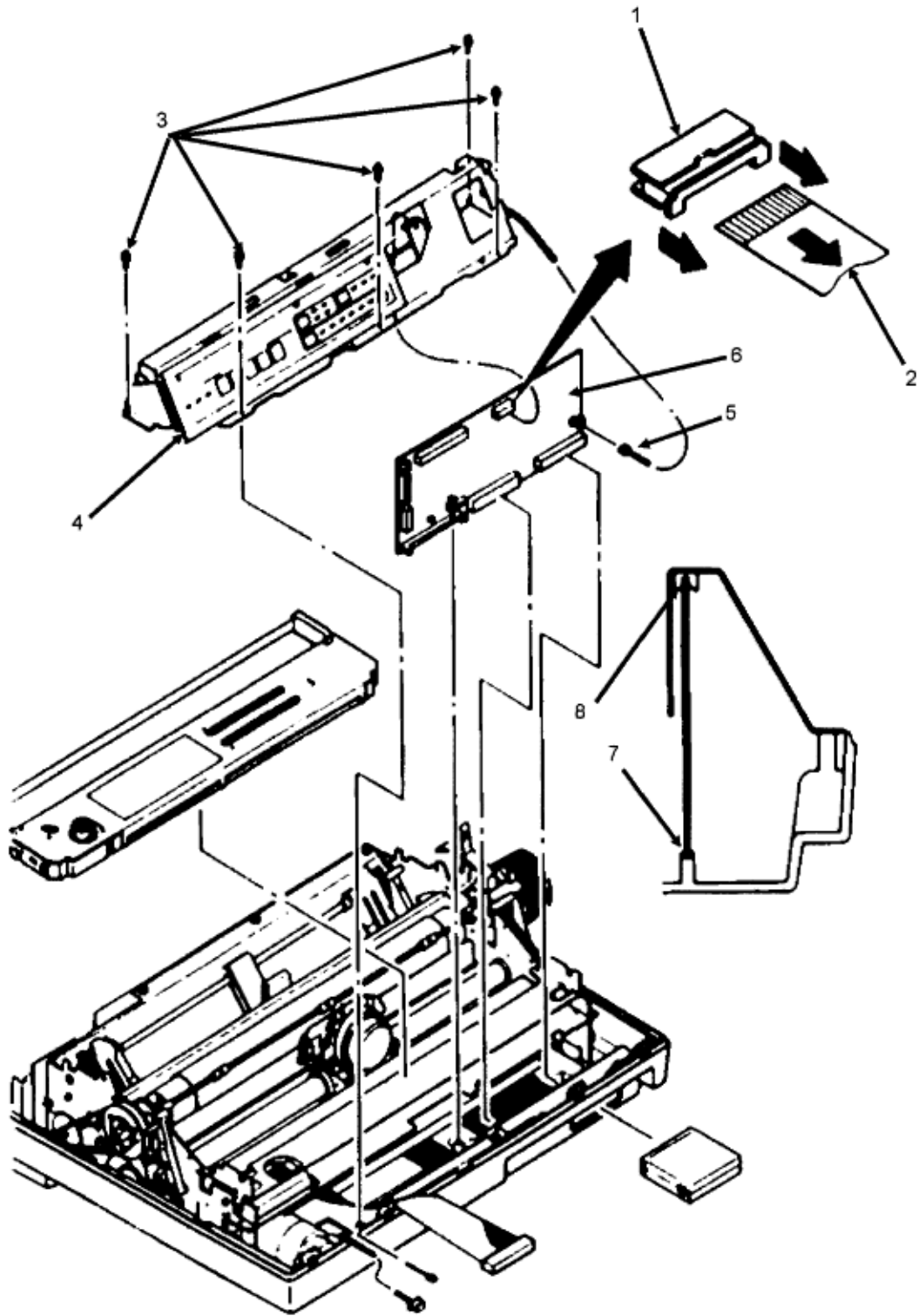

Copyright 1997, Okidata, Division of OKI America, Inc. All rights reserved. See the OKIDATA Business Partner Exchange (BPX) for any updates to this material. (<http://bpx.okidata.com>)

3.2.07 Interface Connector Board (LQPN)

NOTE:

To allow easier access to the mounting screw and cables, configure the interface connector board to use the serial interface connector.

1. Remove the upper cover assembly ([3.2.04](#) ).
2. Disconnect connectors CN102 (1) and CN103 (2).
3. Remove the two mounting screws (3).
4. Lift the interface connector board (4).
5. Detach connector CN101 (5).
6. Remove the interface connector board.

NOTE:

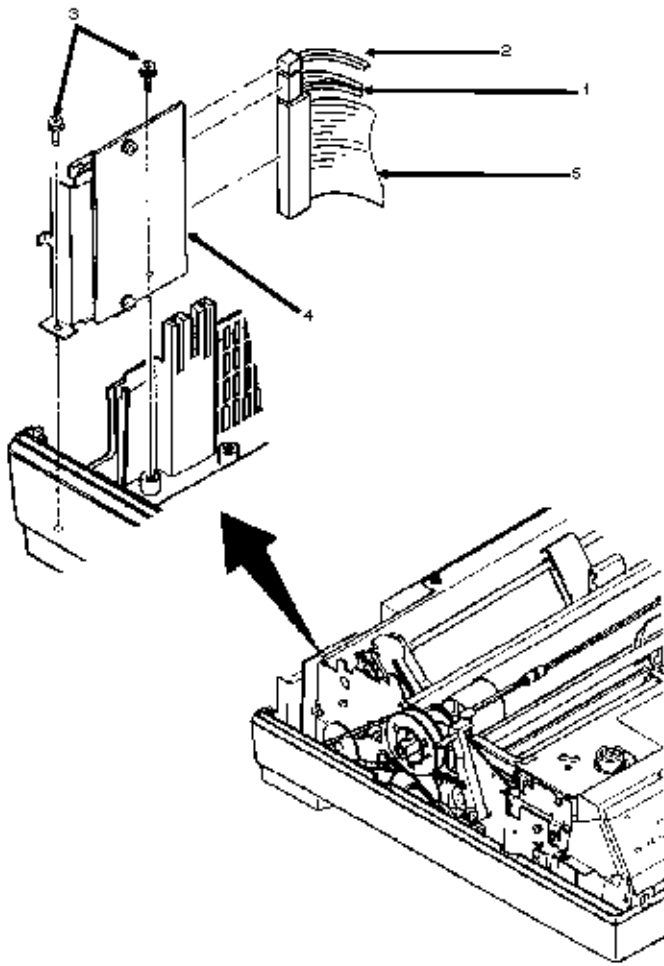

After assembly, configure the interface connector board (if necessary).

[P/N 55034501 PCB: LQPN-Interface Connection RSPL B.2.03 \[Assembly\]](#) 



Copyright 1997, Okidata, Division of OKI America, Inc. All rights reserved. See the OKIDATA Business Partner Exchange (BPX) for any updates to this material. (<http://bpx.okidata.com>)

3.2.08 Printer Mechanism

1. Remove the upper cover assembly ([3.2.04](#) ).
2. Remove the control board ([3.2.06](#) ).
3. Detach connectors CN102 (1) and CN103 (2) from the interface connector board.
4. Remove the three mounting screws (3) at the rear of the printer mechanism (4).
5. Remove the three mounting screws and brackets (5). There are two on the left side of the printer mechanism and one on the right side.

CAUTION:

Do not grasp the ribbon cartridge bracket, paper chute, or the guide shaft of the sheet feeder assembly when lifting the printer during the next step. These parts are easily bent.

6. While holding the base tray, lift the printer mechanism and remove it.

NOTE:

When assembling the printer, do not allow cables to get caught under the control board.

P/N 50213301 Frame: Base [B.2.08](#) , [B.2.11](#) 

P/N 50512923 Rubber Grommet (in base) [B.2.08](#) , [B.2.11](#) 

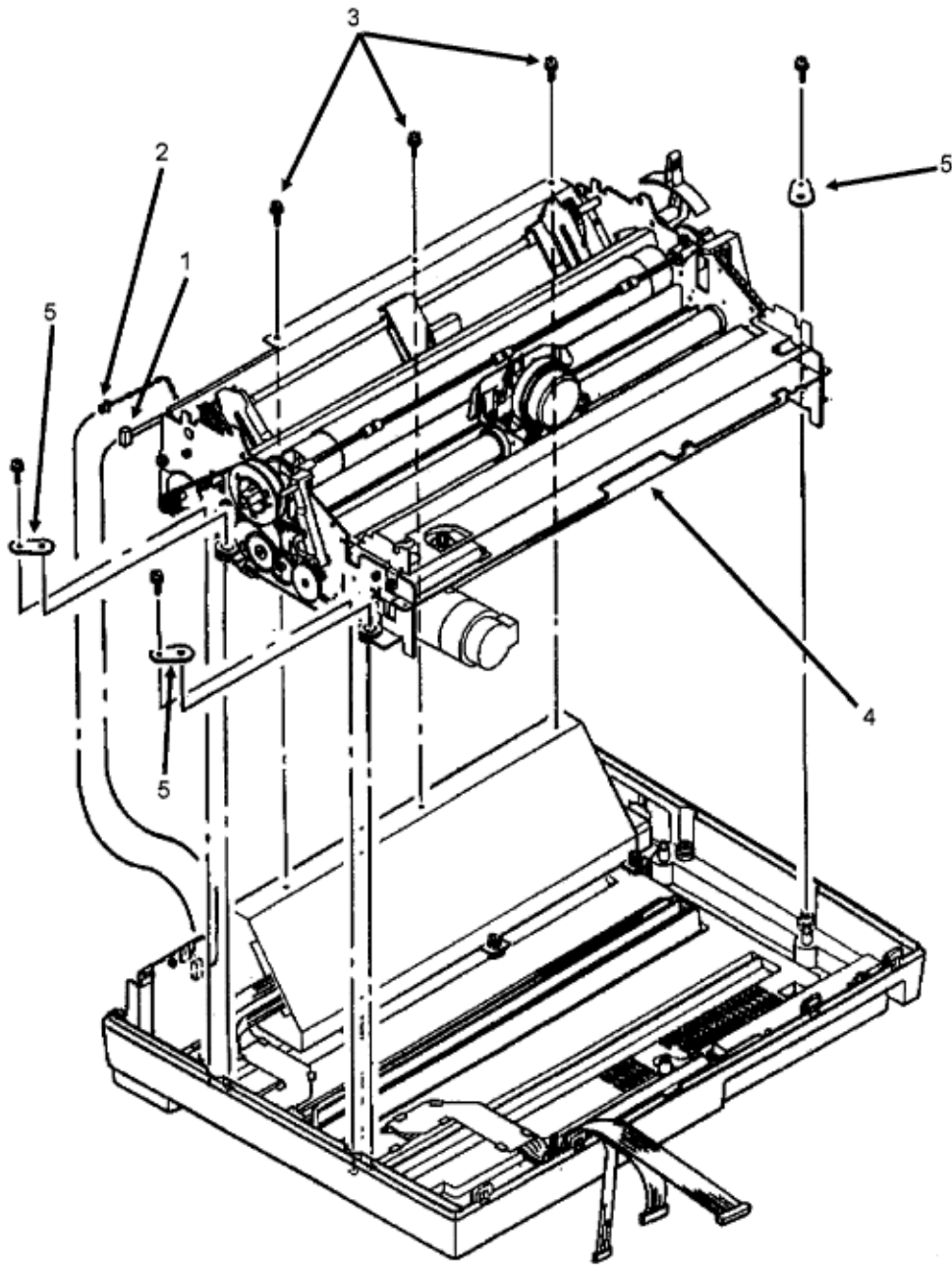

Copyright 1997, Okidata, Division of OKI America, Inc. All rights reserved. See the OKIDATA Business Partner Exchange (BPX) for any updates to this material. (<http://bpx.okidata.com>)

3.2.09 Platen Assembly

1. Remove the upper cover assembly ([3.2.04](#) ).
2. Loosen the three 7 mm line feed motor mounting bolts (1).
3. Move the line feed motor (2) closer to the platen (3) and detach the line feed mini-pitch belt (4).
4. Remove the snap (5A), washer (5B), idle gear spring (5C) and idle gear (5D).
5. Remove the screw (6) and detach the gear pulley (6A), washer (6B), and platen bearing (6C).
6. Remove the screw (7) and detach the platen gear A (7A) and platen bearing (7B).
7. Push in the platen lever (8), lift the bail, and remove the platen assembly (3).

NOTE:

Perform the line feed belt tension adjustment (3.3.02) after replacing the line feed drive belt.

When cleaning, refer to Section 3.4 of this Service Handbook.

Perform the printhead gap adjustment after installation. Refer to Section 3.3 of this Service Handbook for further information.

[P/N 50054101 Platen: \(Assembly\) RSPL B.2.06](#) , [B.2.09](#) 

[P/N 51302790 Belt: Mini Pitch \(Line Feed\) RSPL B.2.06](#) , [B.2.09](#) 

[P/N 50705603 Snap B.2.08](#) , [B.2.11](#) 

[P/N 54123804 Washer B.2.08](#) , [B.2.11](#) 

[P/N 50910305 Spring: Idle Gear RSPL B.2.07](#) , [B.2.10](#) 

[P/N 51214401 Gear: Idle \(Release Lever\) RSPL B.2.07](#) , [B.2.09](#) 

[P/N 51215001 Pulley: Platen RSPL B.2.06](#) , [B.2.09](#) 

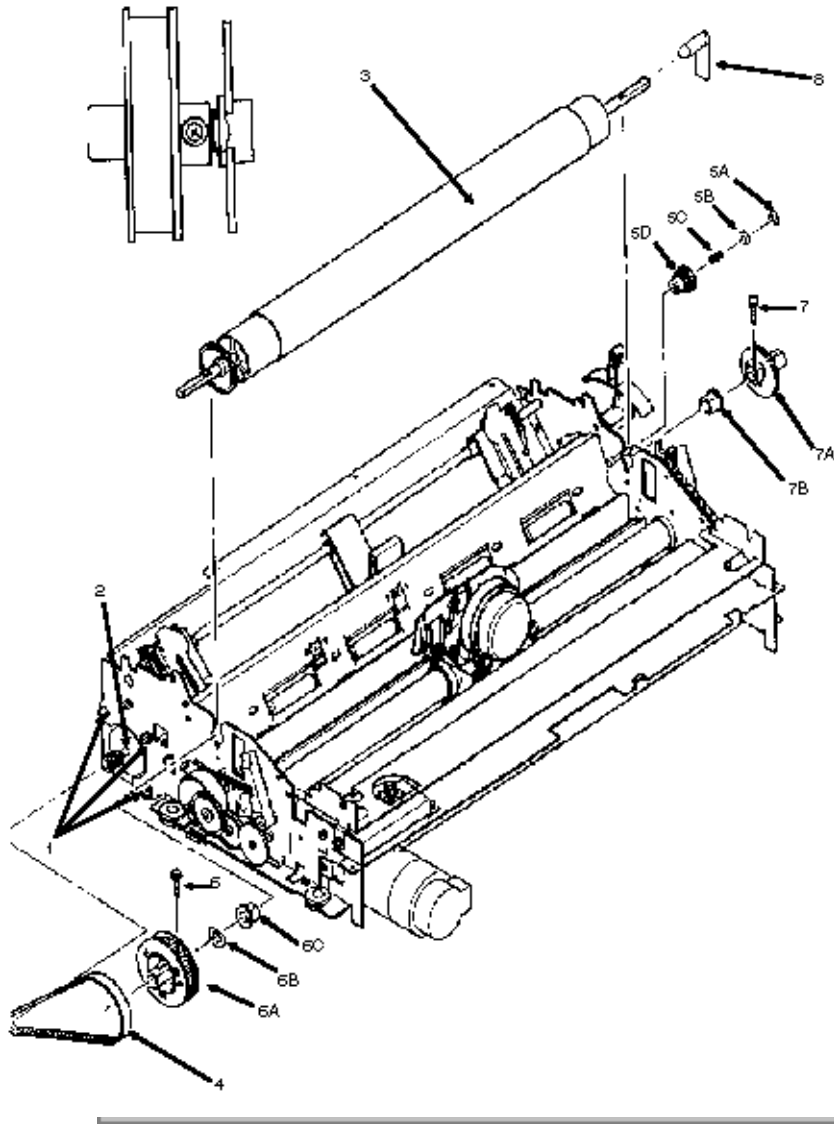

[P/N 51214501 Gear: Platen - A RSPL B.2.06](#) , [B.2.09](#) 

[P/N 51605001 Bearing: Platen B.2.08](#) , [B.2.11](#) 



Copyright 1997, Okidata, Division of OKI America, Inc. All rights reserved. See the OKIDATA Business Partner Exchange (BPX) for any updates to this material. (<http://bpx.okidata.com>)

3.2.10 Line Feed Motor

1. Remove the upper cover assembly (3.2.04 ).
2. Remove the printer mechanism (3.2.09 ).
3. Remove the three mounting bolts and washers (1).
4. Remove the line feed motor (2).

NOTE:



When installing the line feed motor, the cable should be positioned toward the top.

Adjust the line feed belt tension (3.3.02 ) after installing the line feed motor.

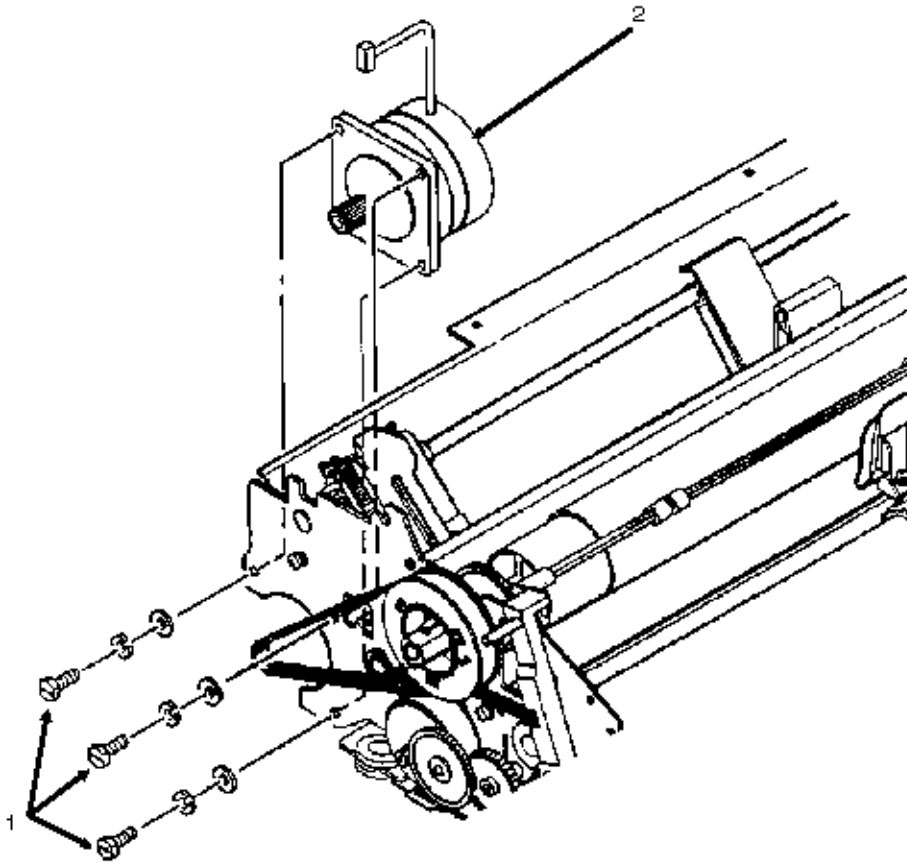
P/N 56508401 Motor: Line Feed Assembly RSPL B.2.06 , 09 



3.2.11 Printhead Cable Assembly

1. Detach the printhead ([3.2.01](#) ) .
2. Remove the upper cover assembly ([3.2.04](#) ) .
3. Remove the printer mechanism ([3.2.09](#) ) .
4. Work from the bottom of the printer mechanism and loosen the two mounting screws (1).
5. Detach tabs (A) and (B) from the frame and remove the cable holder (2).
6. Remove the left shoulder screw [color] (3A) and right should screw [color] (3B).
7. Detach the cartridge bracket (4).
8. Remove the mounting screw (5)
9. Detach the connector clamp (6).
10. Detach the head cable connector (7) from the carriage frame (8).
11. Lift the front of the printer mechanism and remove the printhead cable assembly by pulling downward.

NOTE:

The ribbon cartridge balance spring is NOT shown. Refer to Appendix B of this Service Handbook for further information.

[P/N 50312103 Screw: Shoulder Left \(Color\) RSPL B.2.10](#) 

[P/N 50312106 Screw: Shoulder Right \(Color\) RSPL B.2.10](#) 

[P/N N/A Cartridge Bracket](#)

[P/N N/A Clamp B.2.12](#) , **[B2.13](#)** 

[P/N 56614201 Cable: Printhead Assembly RSPL B.2.12](#) , **[B2.13](#)** 

[P/N 50910601 Spring: Ribbon Cartridge Balance \(Color\) RSPL B.2.10](#) 

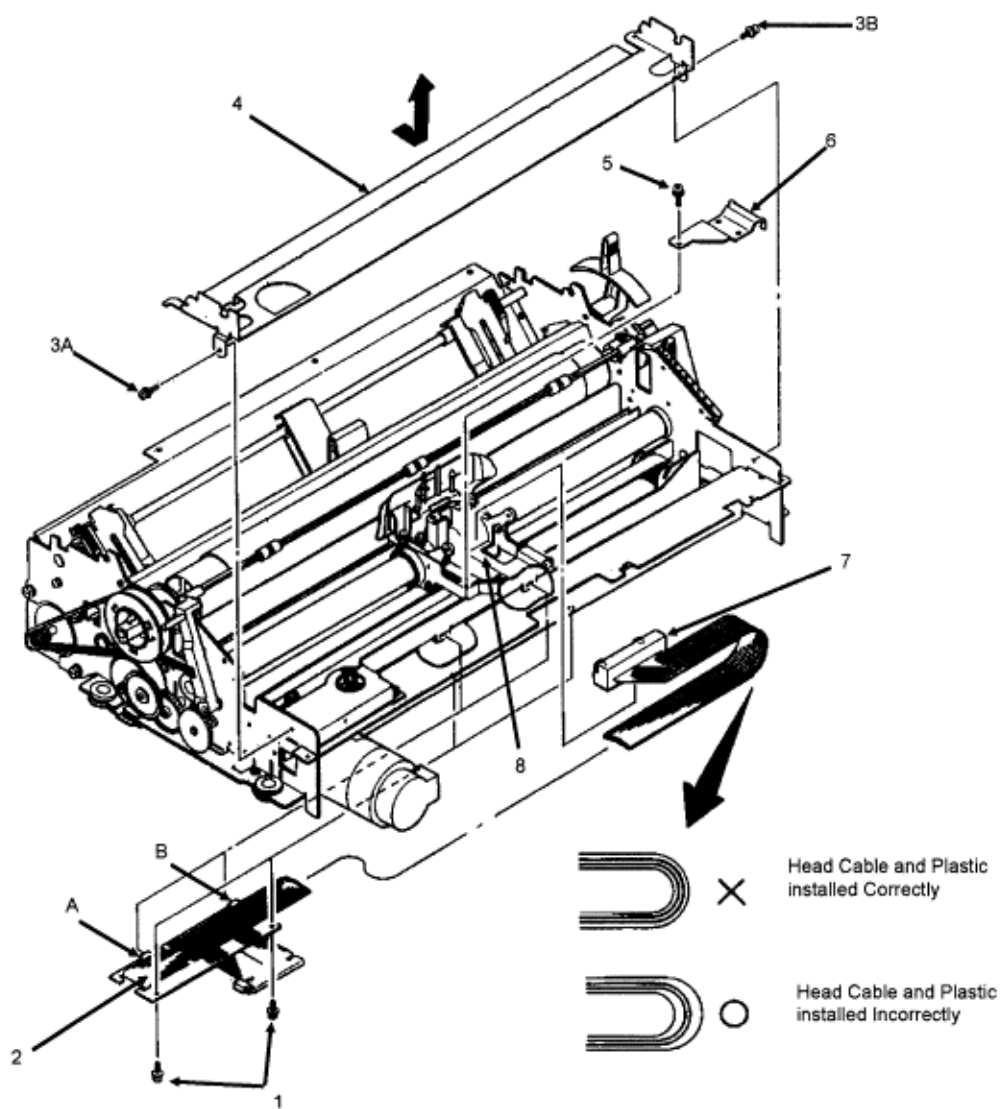

Copyright 1997, Okidata, Division of OKI America, Inc. All rights reserved. See the OKIDATA Business Partner Exchange (BPX) for any updates to this material. (<http://bpx.okidata.com>)

3.2.12 Sensor Board

1. Remove the upper cover assembly [\(3.2.04 !\[\]\(9dc885fa0d6d341860a6e69645e59475_img.jpg\)\)](#).
2. Remove the printer mechanism [\(3.2.09 !\[\]\(5d2b0686f24c91a69ec6f054f466d184_img.jpg\)\)](#).
3. Raise the front of the printer mechanism.
4. Disconnect cables CN2 (1) and CN3 (2) from the sensor board (3).
5. Remove the three sensor board mounting screws (4).
6. Disconnect connector CN1 (5) and detach the sensor board.

[P/N 55050501 PCB: Sensor \(LQEW or LPRW\) RSPL B.2.06 !\[\]\(83f22ed94ec5517769dd76d702c6bfd8_img.jpg\)](#)

[P/N 55050502 PCB: Sensor \(LQEW-2\) \(Color\) RSPL B.2.10 !\[\]\(8d0f0e0fe25b320c33272c52aec1fbca_img.jpg\)](#)

[P/N 56619101 Cable: Sensor Board Connection RSPL B.2.06 !\[\]\(642aa997563f9a325b310230bb5078b7_img.jpg\) , B.2.09 !\[\]\(9bef82f5a53106f2ad06a2de7acf5bcf_img.jpg\)](#)

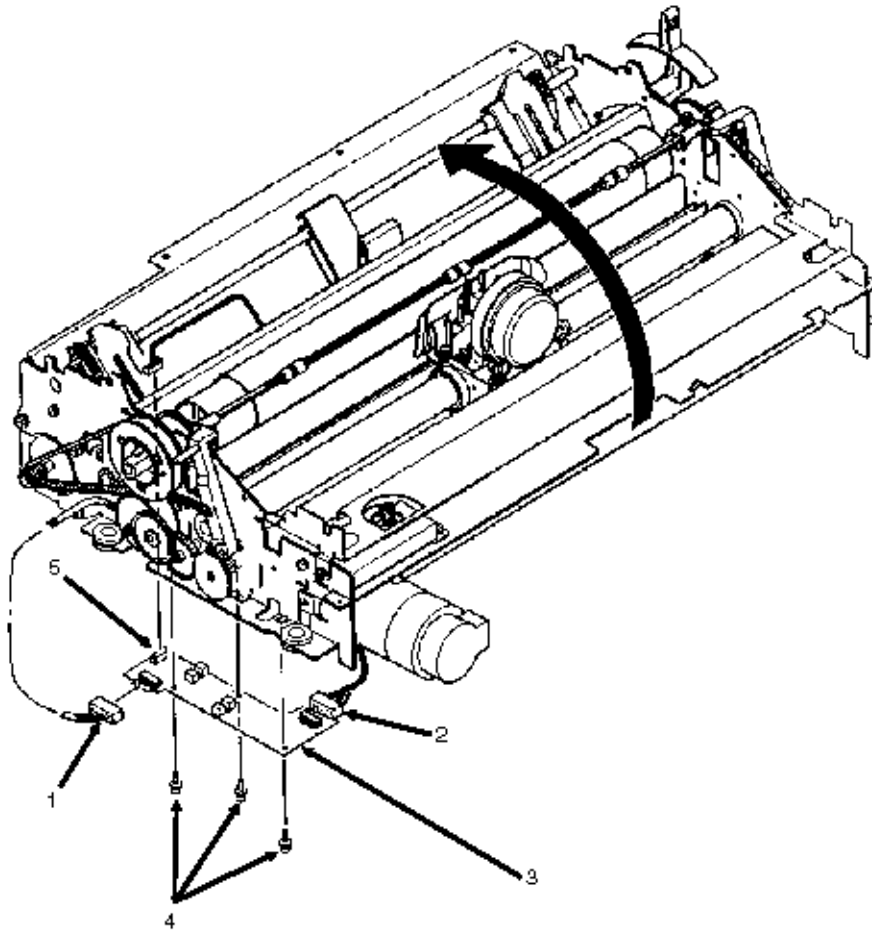

Copyright 1997, Okidata, Division of OKI America, Inc. All rights reserved. See the OKIDATA Business Partner Exchange (BPX) for any updates to this material. (<http://bpx.okidata.com>)



Service Guide ML393/ML393CPlus

Chapter 3 Maintenance

3.2.13 Ribbon Feed Assembly

1. Remove the upper cover assembly ([3.2.04](#)).
2. Remove the printer mechanism ([3.2.08](#)).
3. Remove the left shoulder screw [color] (1A) and right should screw [color] (1B).
4. Detach the cartridge bracket (2).
5. Remove the two mounting screws (3).
6. Detach the ribbon feed assembly (4).

NOTE:

When assembling, install the ribbon drive assembly so that the gear teeth contact properly (5). The gears must not bind together.

The ribbon cartridge balance spring is NOT shown. Refer to Appendix B of this Service Handbook for further information.

[P/N 50312103 Screw: Shoulder Left \(Color\) RSPL B.2.10](#)

[P/N 50312106 Screw: Shoulder Right \(Color\) RSPL B.2.10](#)

[P/N N/A Cartridge Bracket](#)

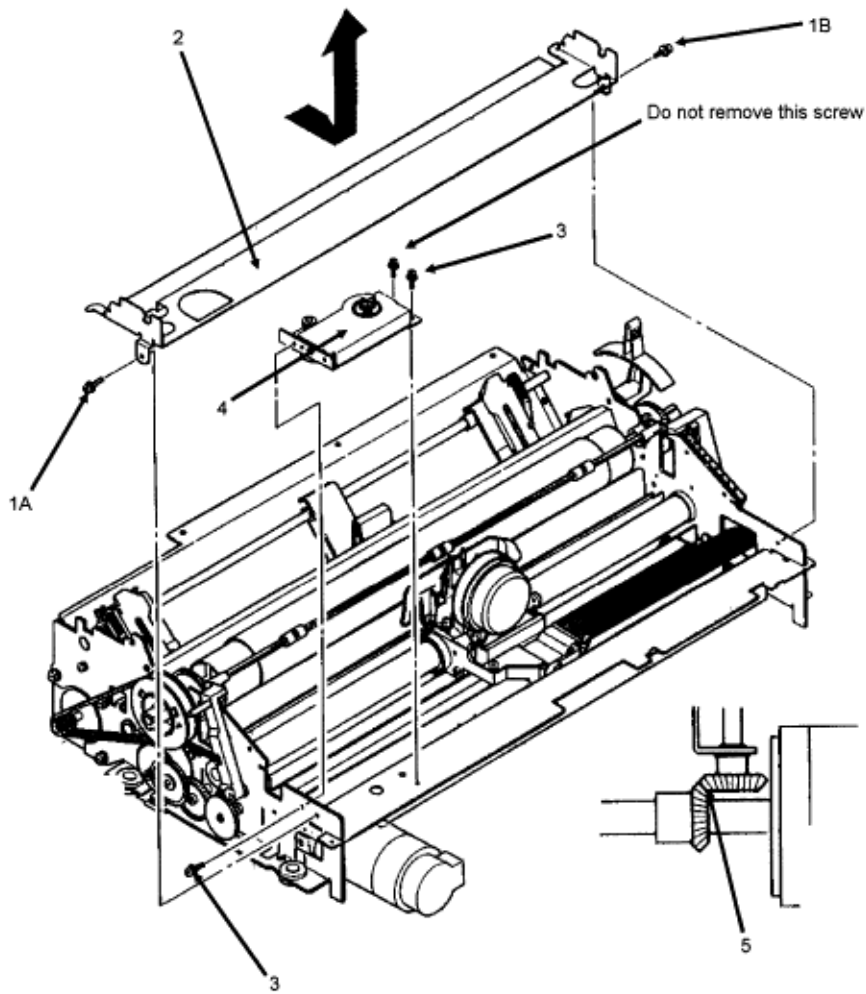

[P/N 50054301 Assembly: Ribbon Feed RSPL B.2.07](#) , **[B.2.10](#)**

[P/N 50910601 Spring: Ribbon Cartridge Balance \(Color\) RSPL B.2.10](#)



Copyright 1997, Okidata, Division of OKI America, Inc. All rights reserved. See the OKIDATA Business Partner Exchange (BPX) for any updates to this material. (<http://bpx.okidata.com>)

3.2.14 Space Motor Assembly

1. Remove the printhead ([3.2.01](#) ) .
2. Remove the upper cover assembly ([3.2.04](#) ) .
3. Remove the ribbon feed assembly ([3.2.13](#) ) .
4. Loosen the two belt pulley bracket mounting screws (1).
5. While pushing the belt pulley bracket (2) to the left, temporarily tighten the two screws. This will ease the tension on the space belt.
6. Remove the three space motor mounting screws (3).
7. Remove the space motor (4) by pulling it toward the front of the printer.

NOTE:



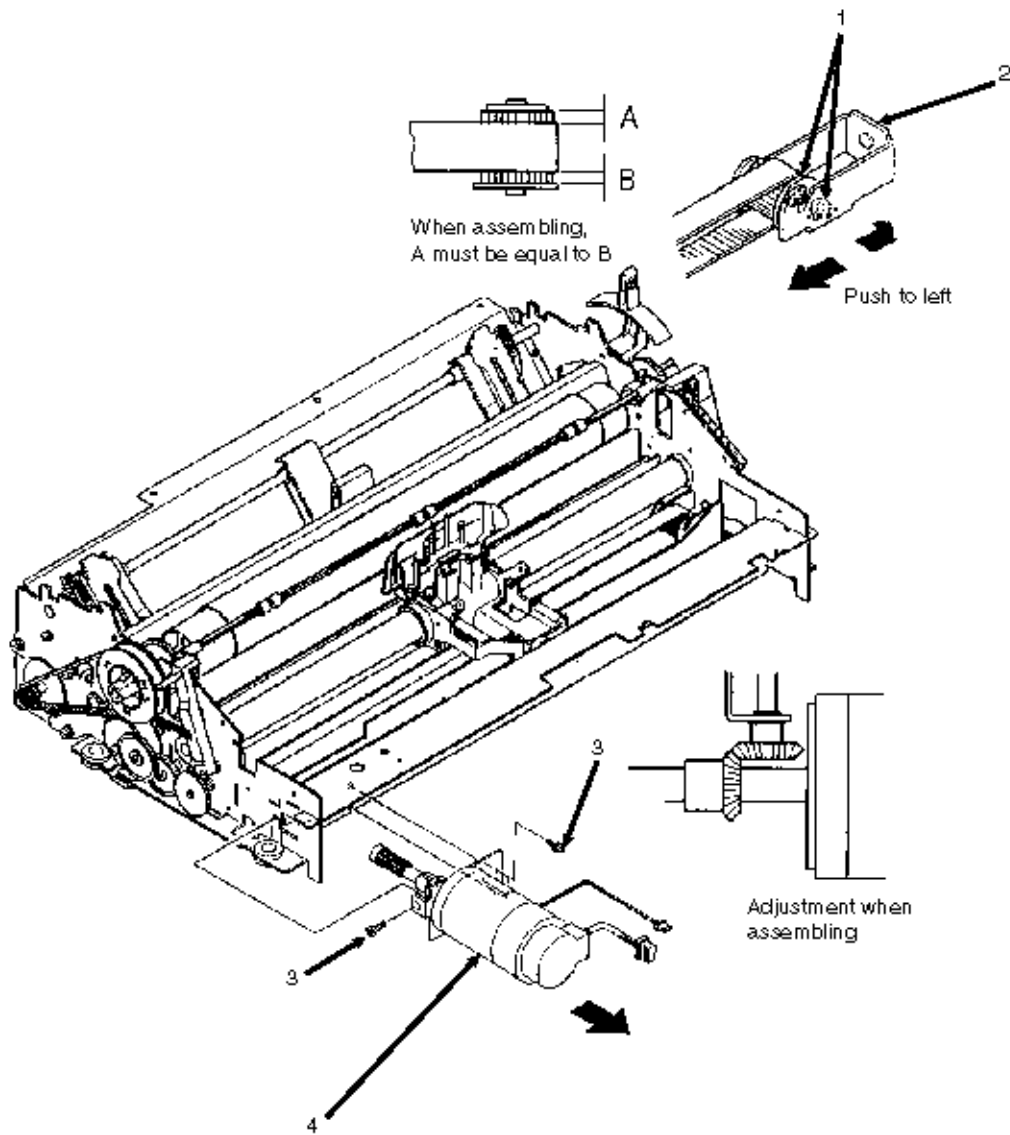

Perform the printhead gap adjustment after installation. Refer to Section 3.3 of this Service Handbook for further information.

[P/N 56506201 Motor: Space Assembly RSPL B.2.06](#)  , [B.2.09](#) 



Copyright 1997, Okidata, Division of OKI America, Inc. All rights reserved. See the OKIDATA Business Partner Exchange (BPX) for any updates to this material. (<http://bpx.okidata.com>)



3.2.15 Space Belt

1. Remove the printhead ([3.2.01](#) )
2. Remove the upper cover assembly ([3.2.04](#) )
3. Remove the head cable assembly ([3.2.11](#) )
4. Remove the space motor assembly ([3.2.14](#) )
5. Remove the mounting screw (1).
6. Detach the belt clamp (2).
7. Remove the idle pulley (3) from the idle pulley shaft (4) and detach the mini-pitch space belt (5).

NOTE:

When installing the belt clamp, make sure that the ribbed side is facing up as shown.

P/N 50702301 Clamp: Belt RSPL [B.2.12](#) , [B.2.13](#) 

P/N 51215601 Pulley: Idle [B.2.08](#) , [B2.11](#) 

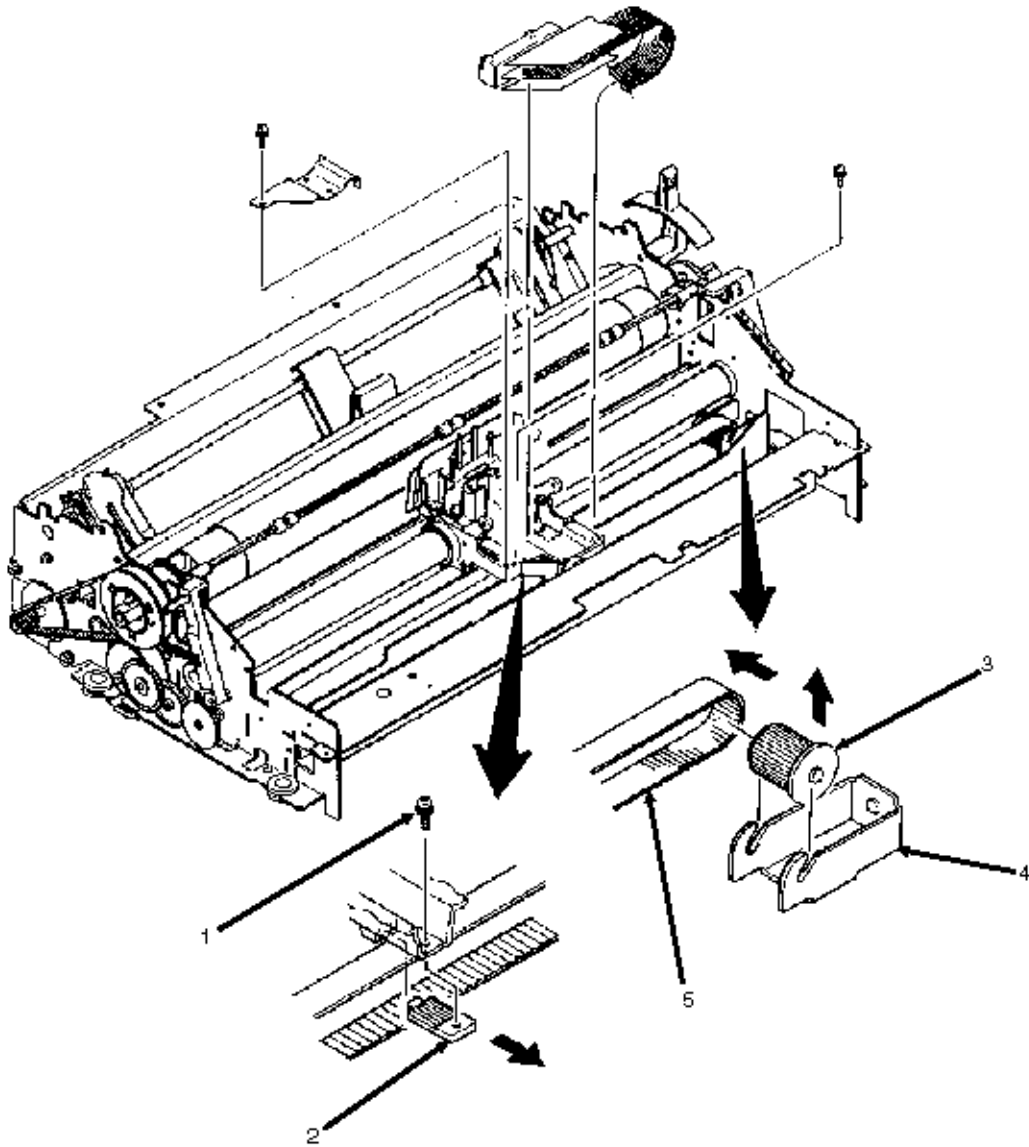

P/N 53327801 Shaft: Idle Pulley [B.2.08](#) , [B2.11](#) 

P/N 51303101 Belt: Mini Pitch (Space) RSPL [B.2.12](#) , [B.2.13](#) 





Copyright 1997, Okidata, Division of OKI America, Inc. All rights reserved. See the OKIDATA Business Partner Exchange (BPX) for any updates to this material. (<http://bpx.okidata.com>)

3.2.16 Bail/Ribbon Motor Assembly

1. Remove the upper cover assembly (3.2.04 ).
2. Remove the printer mechanism (3.2.09 ).
3. Disconnect connector CN2 (1).
4. Remove the two mounting screws (2).
5. Detach the bail/ribbon motor assembly (3).



NOTE:

When assembling, install the bail/ribbon motor assembly so that the gear teeth contact properly. The gears must not bind together.

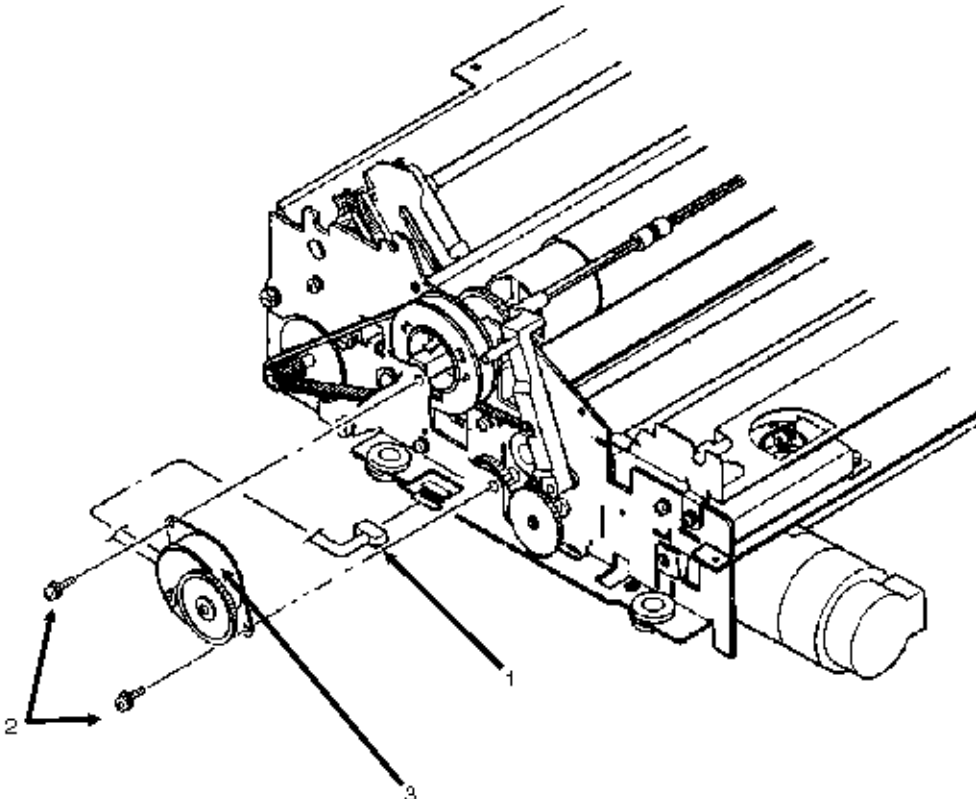
P/N 56506301 Motor: Step (Bail Arm) Assembly [RSPL B.2.07](#) , [B.2.10](#) 







3.2.17 Paper Bail Assembly



1. Remove the upper cover assembly ([3.2.04](#) ).
2. Remove the printer mechanism ([3.2.08](#) ).
3. Remove the bail/ribbon motor assembly ([3.2.16](#) ).
4. Detach the left bail arm spring (1A) and right bail arm spring (1B).
5. Remove the bail arm idle gear (2).
6. Detach the E snap ring and remove the bail open cam (3).
7. Detach the E snap ring (4) and remove the left bail arm (5) from the indicator shaft assembly (6) by pulling to the left.
8. Remove the right bail arm (7) by pulling to the right while expanding the clamps (8).
9. Detach the right bail arm from the indicator shaft assembly.

NOTE:*Installation*

The left bail arm spring (1A) is longer than the right bail arm spring (1B). Be sure to install each spring on the proper side.

P/N 50910701 Spring: Bail Arm (Left) [RSPL B.2.07](#) , [B.2.10](#) 

P/N 50910801 Spring: Bail Arm (Right) [RSPL B.2.07](#) , [B.2.10](#) 

P/N 51210201 Gear: Idle (Bail Arm) [RSPL B.2.07](#) , [B.2.10](#) 

P/N 51214701 Cam: Bail Open (Black) [RSPL B.2.07](#) 

P/N 53478501 Arm: Left Bail [RSPL B.2.07](#) , [B.2.10](#) 

P/N 50054401 Assembly: Indicator Shaft [RSPL B.2.07](#) , [B.2.10](#) 

P/N 53478502 Arm: Right Bail [RSPL B.2.07](#) , [B.2.10](#) 

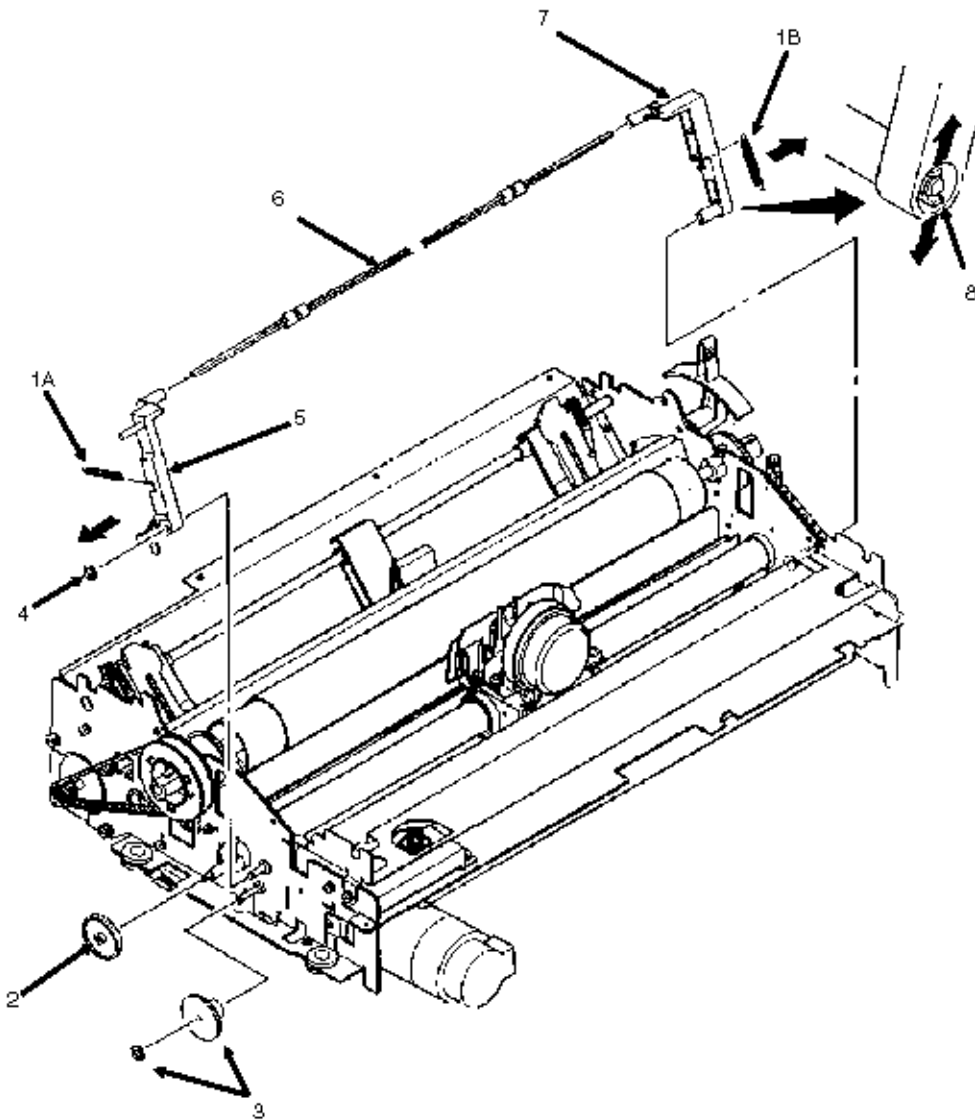

Copyright 1997, Okidata, Division of OKI America, Inc. All rights reserved. See the OKIDATA Business Partner Exchange (BPX) for any updates to this material. (<http://bpx.okidata.com>)

3.2.18 Carriage and Carriage Shaft

Procedure

1. Remove the printhead [\(3.2.01 !\[\]\(815df092dd722ee9268ef8e6d0193e3a_img.jpg\)](#)).
2. Remove the upper cover assembly [\(3.2.04 !\[\]\(c72edb9626cad660f3a9f5fb0f22a68c_img.jpg\)](#)).
3. Loosen the screw (1) and slide it towards the back of the printer. This screw affects the placement of the slide guide (1A).
4. Loosen the mounting screw (2) and detach the left eccentric collar (3).
5. Remove the screw and detach the blue printhead gap adjusting lever. (*Not shown*)
6. Loosen the screw (4) and detach the right eccentric collar (5).
7. Remove the two stopper cushion rings (6).
8. Slide the carriage shaft (7) to the right and remove the carriage (8) and round spacer (*Not Shown*).
9. Continue sliding the carriage shaft to the right, then remove the carriage shaft.

NOTE:

Installation

The protrusions on the eccentric collars face the outside of the printer.

The long extension end of the carriage shaft goes to the right side of the printer.

The printhead gap adjust lever is NOT shown. Refer to Appendix B of this Service Handbook for further information.

When cleaning, refer to Section 3.4 of this Service Handbook .

Perform the printhead gap adjustment after installation. Refer to Section 3.3  of this Service Handbook for further information.

The parts list appears on the following pages.

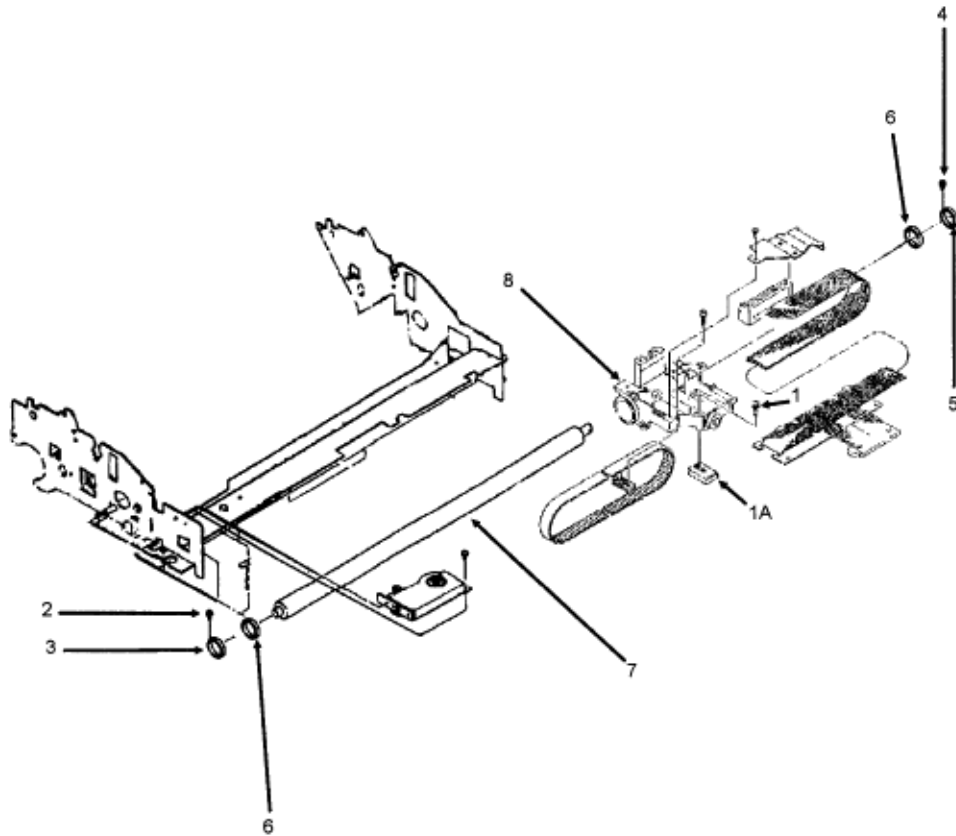



Copyright 1997, Okidata, Division of OKI America, Inc. All rights reserved. See the OKIDATA Business Partner Exchange (BPX) for any updates to this material. (<http://bpx.okidata.com>)



Service Guide ML393/ML393CPlus



Chapter 3 Maintenance

Parts List

P/N 51005501 Guide: Slide [B.2.12](#) , [B.2.13](#) 

P/N 50703701 Collar: Eccentric (Carr. Rail) [B.2.08](#) , [B.2.11](#)  Head Adjustment



P/N 53478401 Lever: Printhead Gap Adjust [RSPL B.2.07](#) , [B.2.10](#) 

P/N 50705701 Ring: Cushion (Stopper) [B.2.08](#) , [B.2.11](#) 

P/N 51110301 Shaft: Carriage [B.2.08](#) , [B.2.11](#) 

P/N 50057601 Carriage: Black Assembly [B.2.12](#) 

P/N 50069401 Carriage: Color Assembly, [B.2.13](#) 

P/N N/A Spacer: Round [B.2.12](#) , [B.2.13](#) 

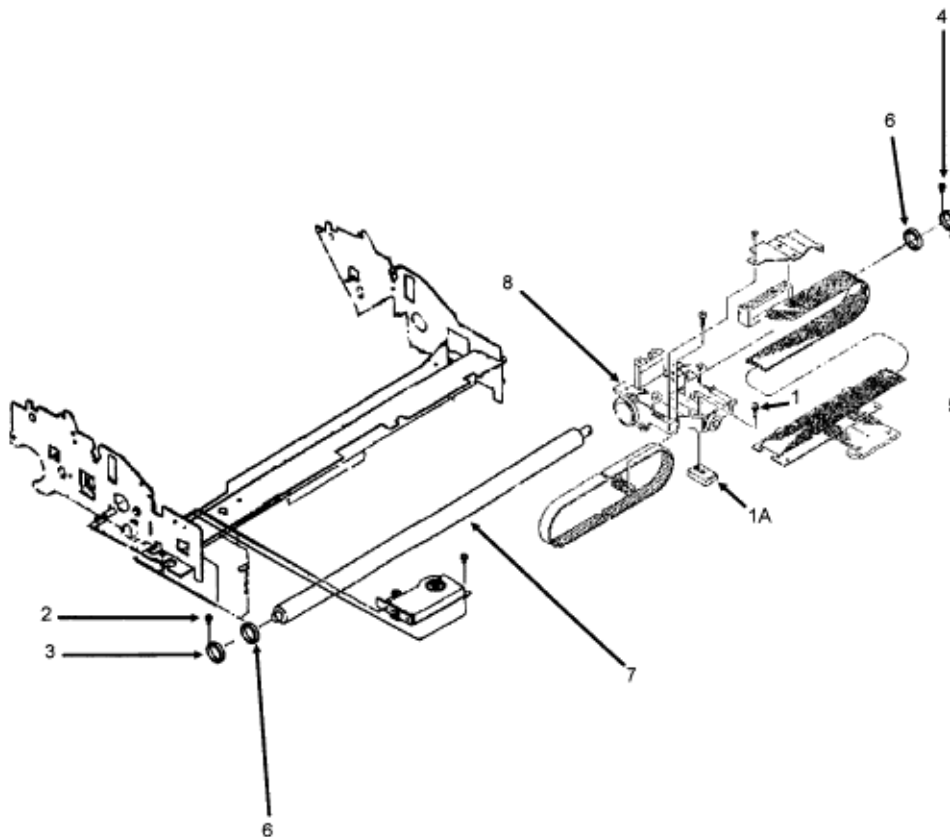



Service Guide ML393/ML393CPlus

Chapter 3 Maintenance

3.2.19 Paper Pressure Guide

1. Remove the printhead ([3.2.01](#)).
2. Remove the upper cover assembly ([3.2.04](#)).
3. Remove the two paper chute springs (1) located on each side of the paper chute assembly (2).
4. Loosen the two screws, located under the post on the left side of the printer mechanism. [*Not Shown*]
5. Remove the release lever detent spring (3), located on the release lever (4) at the right side of the printer.
6. Separate the claws and remove the release lever (4).
7. Remove the release lever guide block. (*Not Shown. Refer to Appendix B of this Service Handbook.*)
8. Remove the paper pressure bar (5) by sliding it to the right.
9. Using needle-nose pliers, squeeze the nylon latch (7A) to release the cut-sheet paper-end sensor (7B), which is located at the left side of the printer mechanism.
10. Lift and remove the paper chute assembly.
11. This is the rear guide (7).

NOTE:

Installation

The flat side of the paper pressure bar faces up.

P/N 50907502 Spring: (Paper Chute) [RSPL B.2.06](#) , [B.2.09](#)

P/N 50082001 Assembly: Paper Chute [B.2.08](#) , [B.2.11](#)

P/N 50910201 Spring: Detent (Release Lever) [RSPL B.2.07](#) , [B.2.09](#)

P/N 53478706 Lever: Release RSPL [RSPL B.2.06](#) , [B.2.09](#)

P/N 53478801 Block: Release Lever Guide RSPL [B.2.08](#) , [B.2.11](#)

P/N N/A Paper Pressure Bar [B.2.08](#) , [B.2.11](#)

P/N 55034801 Sensor: Cut-Sheet Paper-End [RSPL B.2.07](#) , [B.2.09](#)

P/N N/A Rear Guide [B.2.08](#) , [B.2.11](#)

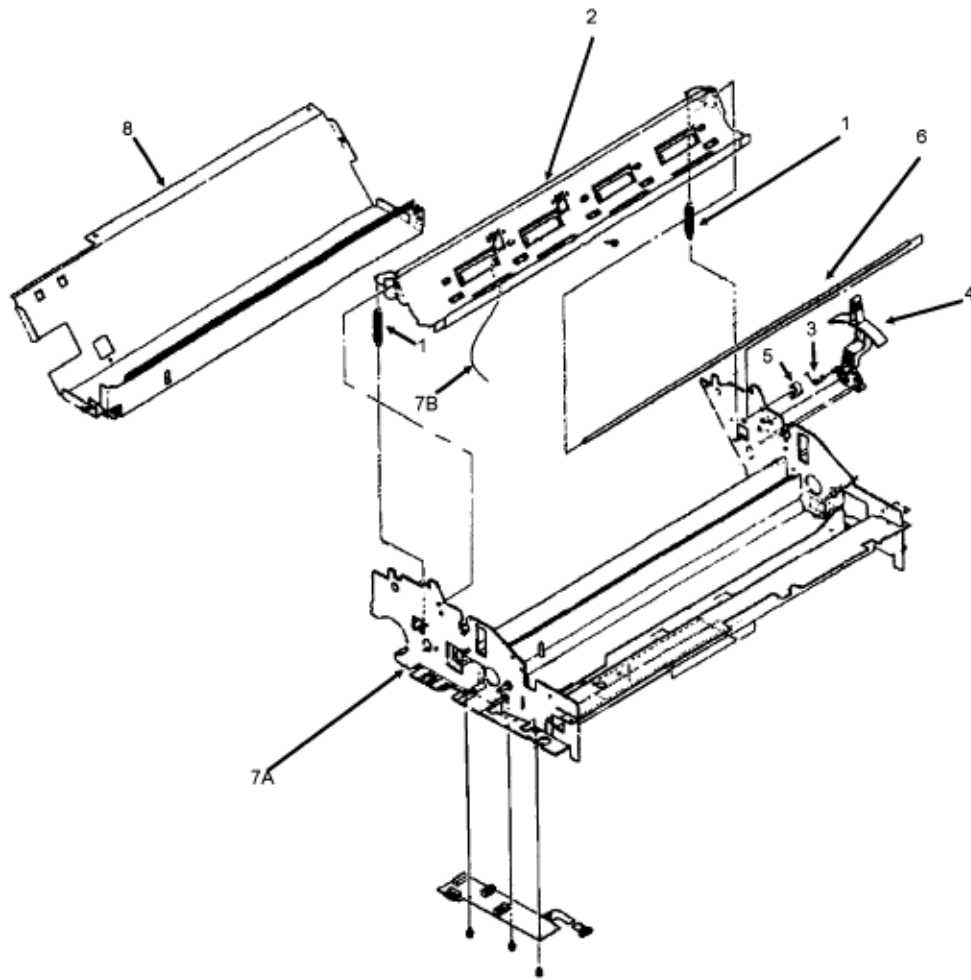

Copyright 1997, Okidata, Division of OKI America, Inc. All rights reserved. See the OKIDATA Business Partner Exchange (BPX) for any updates to this material. (<http://bpx.okidata.com>)

3.2.20 Printhead Gap / Release Lever Microswitches

1. Remove the upper cover assembly ([3.2.04](#) ).
2. Remove the mounting screw to remove the adjust and release lever micro switch (1).
3. Push down on the mounting tab and remove the printhead gap microswitch (2).
4. Using a needle nose pliers, detach the nylon cable clamp (3) and remove the harness and switches from the printer mechanism.
5. The printhead gap indication bracket is the plastic piece imprinted with numbers. [*Not Shown*]

P/N 56209901 Switch: Micro (Adj and Rel Lever) [RSPL B.2.06](#)  , [B.2.09](#) 

P/N 53063801 Bracket: PH Gap Indication [RSPL B.2.07](#)  , [B.2.09](#) 

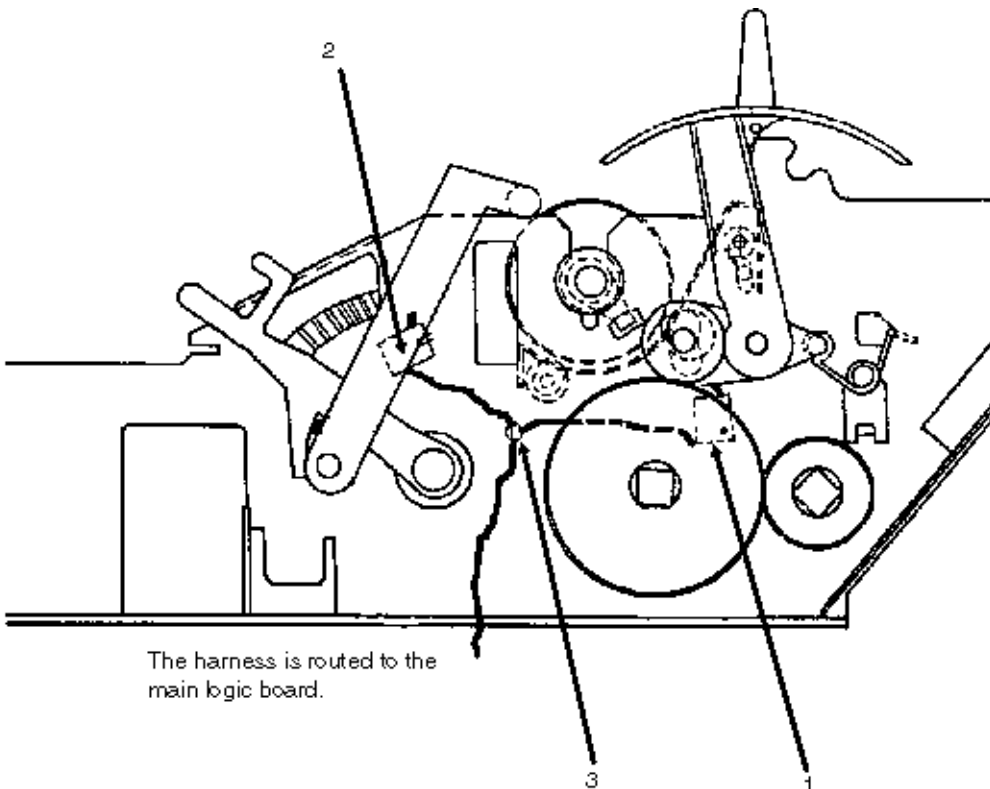

3.2.21 Push Tractor Assembly

Procedure - Disassembly

1. Remove the upper cover assembly ([3.2.04](#) ).
2. Remove the lower center guide A(1A) and lower center guide B (1B).
3. Separate the claws (2) and remove the drive gear A (3A) and drive gear B (3B) from the right side of the printer mechanism. Drive gear B contacts the bushing.
4. Using a needle nose pliers, remove the nylon cable clamp (4).
5. Slide the upper drive shaft (5) to the left and remove it.
6. Slide the lower drive shaft (6) to the left.
7. Remove the upper center guide (7), being careful not to lose the friction piece (8).
8. Remove the lower drive shaft (6).
9. Loosen the two screws (9) [one is located on each side of the printer mechanism].
10. Lift and remove the left push tractor assembly (10A), the right push tractor assembly (10B), and the locking shaft (11).
11. To remove the tractors from the locking shaft, raise the lock lever and slide the tractor off.

Installation Notes appear on the following pages.

The parts list appears on the following pages.

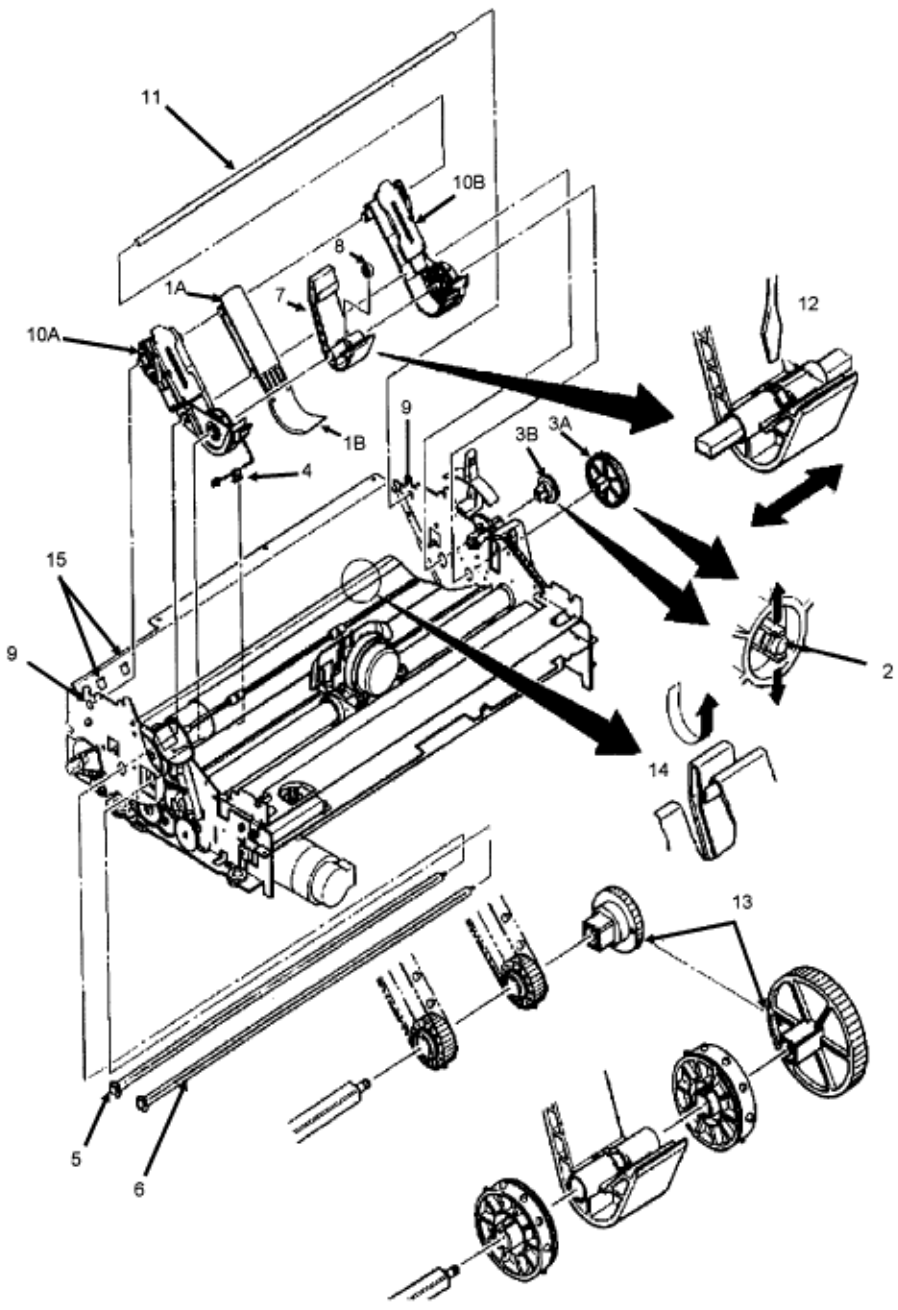

Copyright 1997, Okidata, Division of OKI America, Inc. All rights reserved. See the OKIDATA Business Partner Exchange (BPX) for any updates to this material. (<http://bpx.okidata.com>)

Procedure - Installation Notes**NOTES:**



When installing the push tractor assembly, follow the precautions listed below.



1. Install the friction piece in the upper center guide. If the upper center guide moves easily along the locking shaft, use a standard screwdriver to rotate the friction piece 45 degrees (12).
2. Check the installation; if the guide moves with difficulty, it is properly installed.
3. Synchronize the tractors by aligning the synchronization marks in the same direction.
4. Position the guide holes (13) in the tractor drive gears in the same direction.
5. Position the groove of the upper center guide (7) behind the paper pressure guide (14).
6. The left tractor assembly (10A) must be positioned between the two locking tabs (15).

Parts List

P/N 51002501 Guide: Center Lower - A [RSPL B.2.06](#)  , [B.2.09](#) 

P/N 51002601 Guide: Center Lower - B [RSPL B.2.06](#)  , [B.2.09](#) 

P/N 51214201 Gear: Drive - A [RSPL B.2.07](#)  , [B.2.10](#) 

P/N 51214301 Gear: Drive - B [RSPL B.2.07](#)  , [B.2.10](#) 



P/N 51605101 Bushing [B.2.08](#)  , [B.2.11](#) 



P/N N/A Shaft: Upper Drive [B.2.08](#)  , [B.2.11](#) 



P/N N/A Shaft: Lower Drive [B.2.08](#)  , [B.2.11](#) 

P/N 51002401 Guide: Center Upper [RSPL B.2.06](#)  , [B.2.09](#) 

P/N 51002301 Friction: Piece [RSPL B.2.06](#)  , [B.2.09](#) 

P/N 50054501 Tractor: Push (Left) Assembly [RSPL B.2.06](#)  , [B.2.09](#) 

P/N 50054601 Tractor: Push (Right) Assembly [RSPL B.2.06](#)  , [B.2.09](#) 

P/N N/A Shaft: Locking [B.2.08](#)  , [B.2.11](#) 

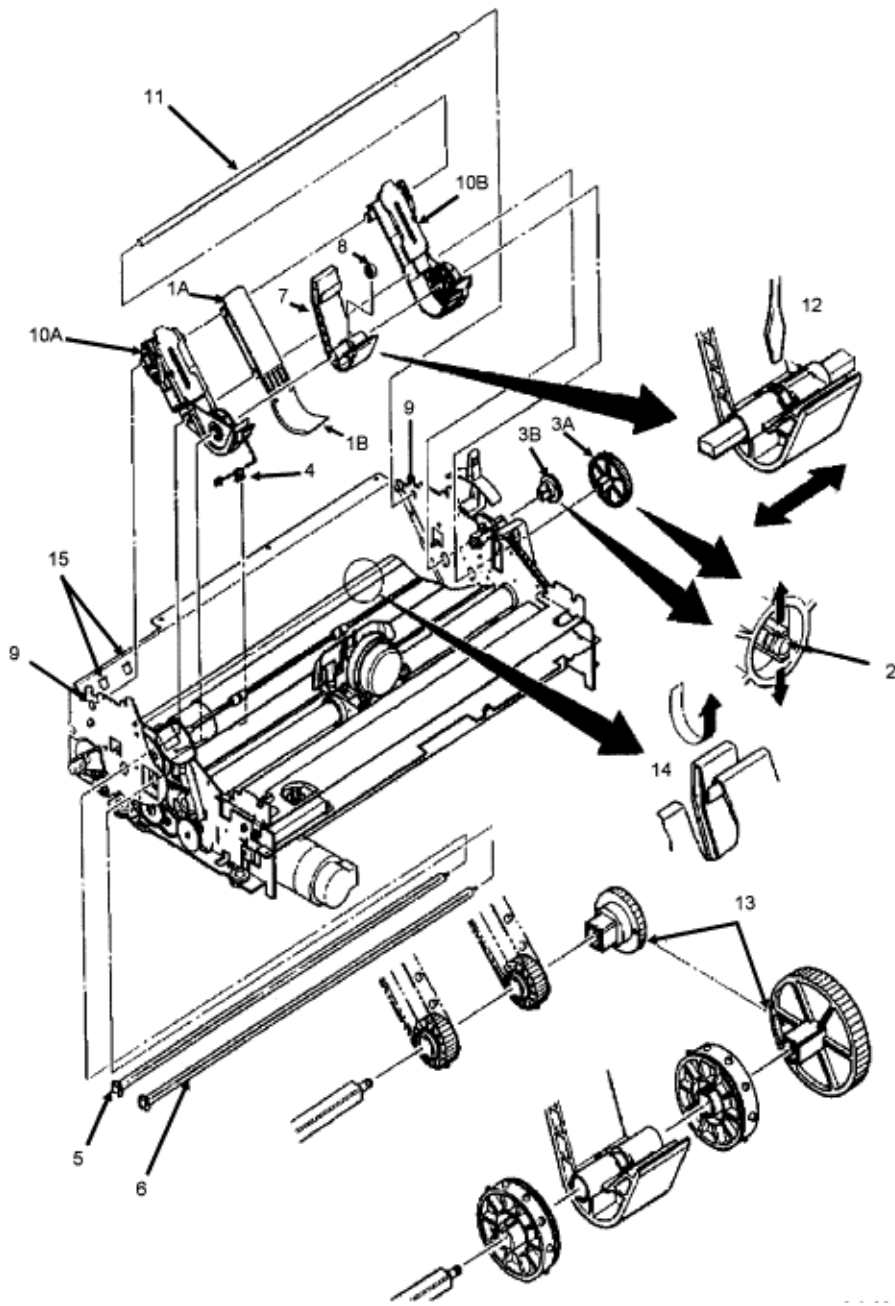

Copyright 1997, Okidata, Division of OKI America, Inc. All rights reserved. See the OKIDATA Business Partner Exchange (BPX) for any updates to this material. (<http://bpx.okidata.com>)

3.2.22 Power Supply Unit

1. Remove the printer mechanism ([3.2.08](#) ).
2. Disconnect the two cables (1) from the left side of the power supply unit (2).
3. Remove the four power supply mounting screws (3).
4. Remove the power supply unit by pulling toward the left-front side of the printer. You must raise the power supply unit slightly so it will become detached from the two guides (A) in the lower cover.

NOTE:

Be careful not to damage the cables with the power supply unit mounting bracket (located at the left/rear of the power supply unit).

[P/N 56406202 Power Supply Assembly \(220 vac\) RSPL B.2.03](#) 

[P/N 56411201 Power Supply Assembly \(120 vac\) RSPL B.2.03](#) 

[P/N 56406301 Power Supply \(220 v\) Option B.2.14](#) 

[P/N 56614101 Cord: Power Connection \(9 Pin\) RSPL B.2.03](#) 

[P/N 56614801 Cord: Power Connection \(13 Pin\) RSPL B.2.03](#) 

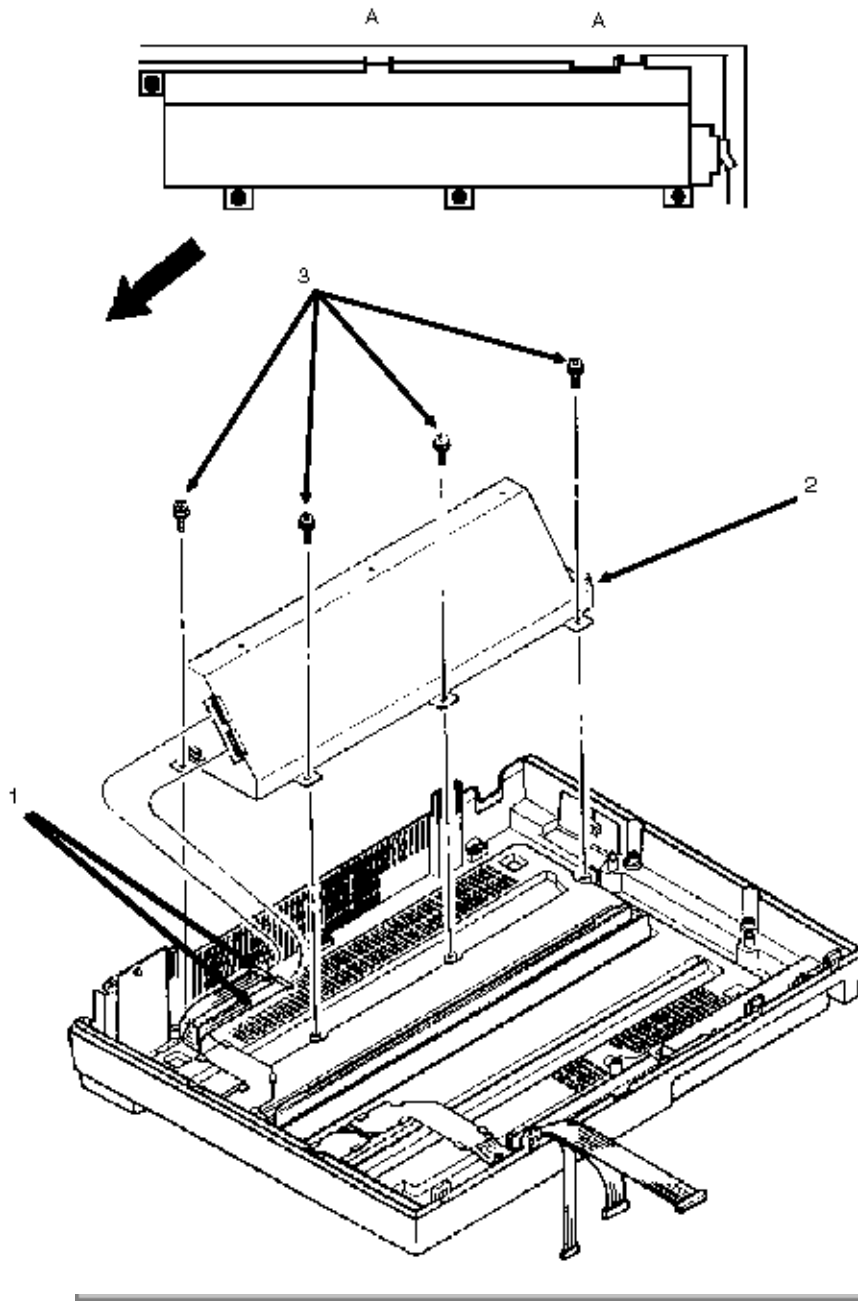

Copyright 1997, Okidata, Division of OKI America, Inc. All rights reserved. See the OKIDATA Business Partner Exchange (BPX) for any updates to this material. (<http://bpx.okidata.com>)



Service Guide ML393/ML393CPlus
Chapter 3 Maintenance

Page: 77

Sections **3.2.23** through **3.2.28** apply to the **Microline 393C-Plus - Color Model Only**

Copyright 1997, Okidata, Division of OKI America, Inc. All rights reserved. See the OKIDATA Business Partner Exchange (BPX) for any updates to this material. (<http://bpx.okidata.com>)

Microline 393C-Plus - Color Model Only**3.2.23 Ribbon Shift Arm Spring / Ribbon Shift Arm**

1. Detach the printer access cover.
2. Remove the ribbon cartridge (1).
3. Remove the shift arm spring (2).
4. Remove the 7 mm mounting bolt (3) and detach the ribbon shift arm (4).

P/N 53478901 Arm: Ribbon Shift (Color) RSPL B.2.13 

P/N 50315401 Screw (Color) RSPL B.2.13 

P/N 50917811 Spring: Ribbon Shift Arm (Color) RSPL B.2.13 

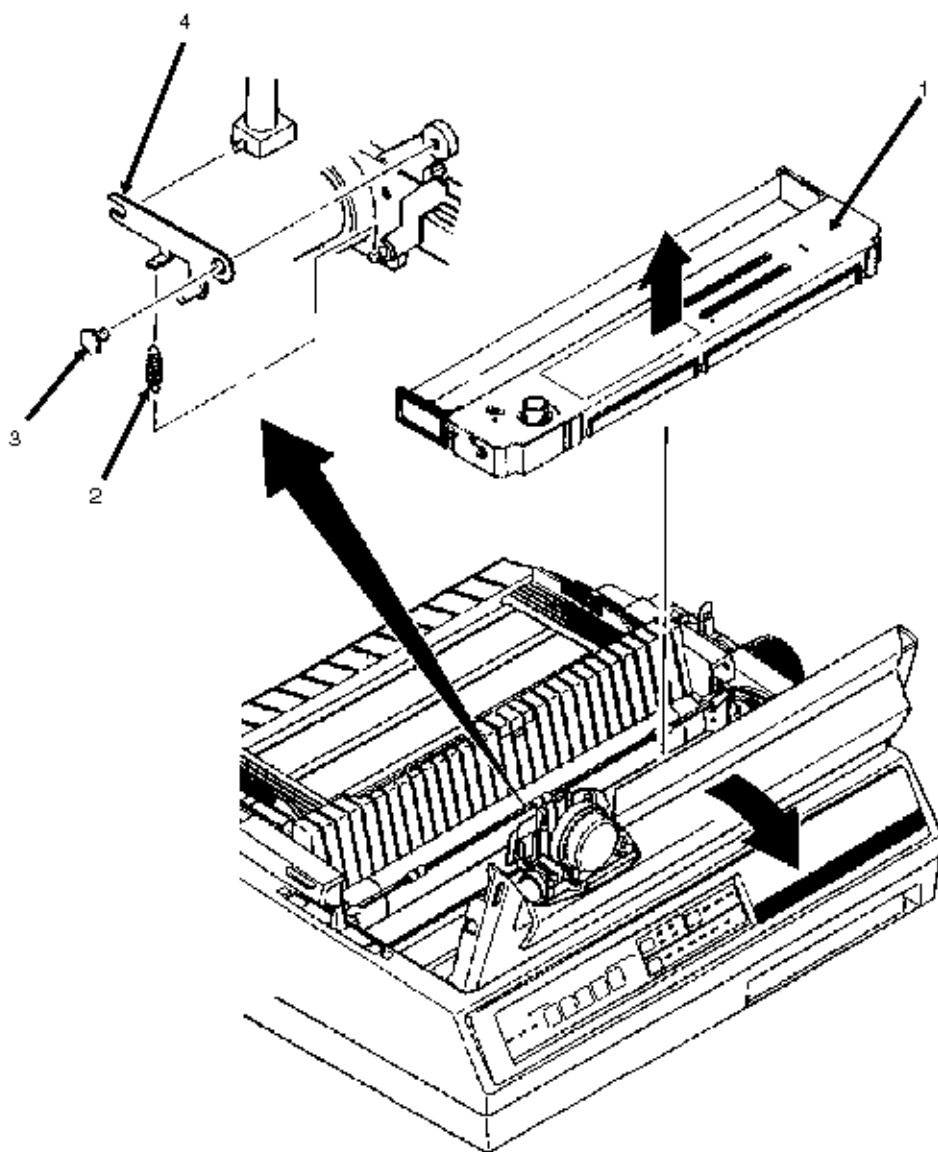

Copyright 1997, Okidata, Division of OKI America, Inc. All rights reserved. See the OKIDATA Business Partner Exchange (BPX) for any updates to this material. (<http://bpx.okidata.com>)

3.2.24 Roller Lever

1. Open the printer access cover.
2. Remove the ribbon cartridge.
3. Remove the shift arm spring ([3.2.23](#) ).
4. Remove the two 7 mm bolts (1) and detach the roller lever (2).

P/N 53479001 Lever: Roller (Color) RSPL B.2.13 

P/N N/A Screw B.2.13 

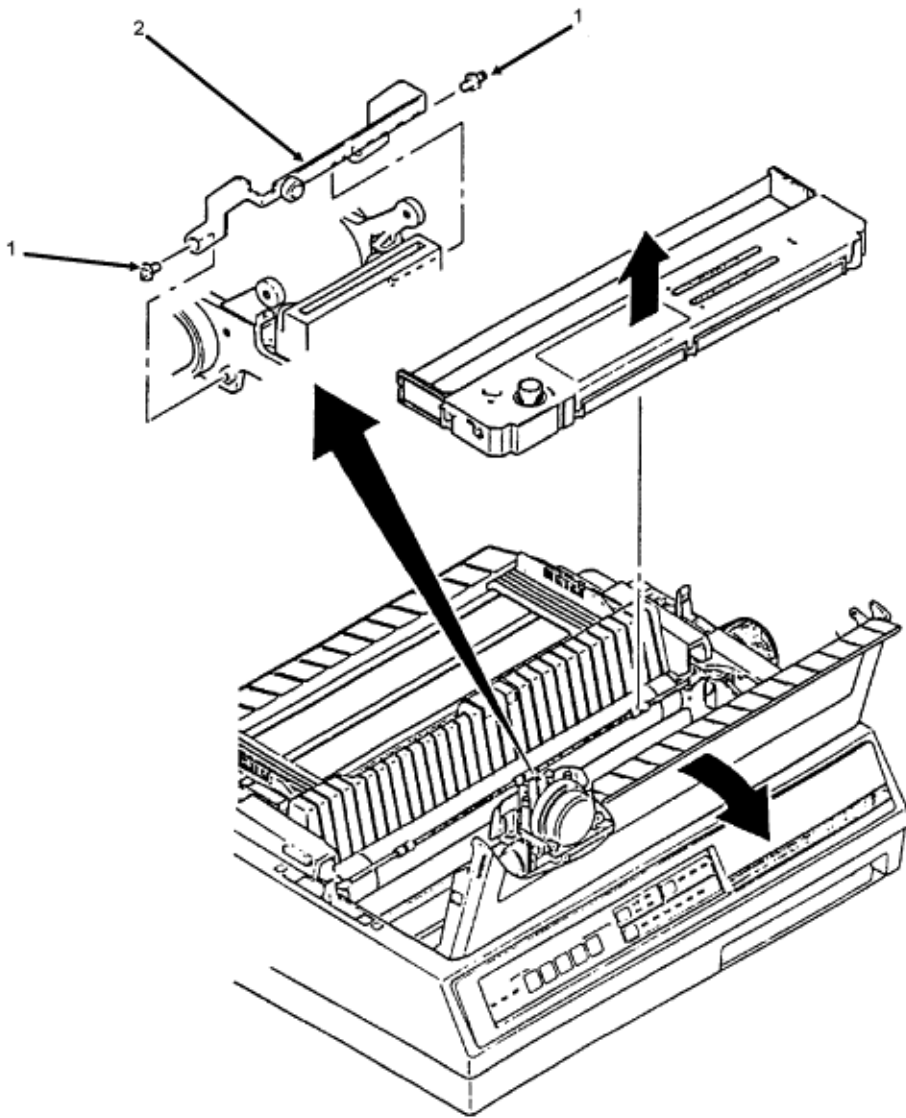

Copyright 1997, Okidata, Division of OKI America, Inc. All rights reserved. See the OKIDATA Business Partner Exchange (BPX) for any updates to this material. (<http://bpx.okidata.com>)

3.2.25 Ribbon Guide

1. Remove the printhead ([3.2.01](#) ).
2. Loosen the 7 mm ribbon shift arm mounting bolt (1) and detach the ribbon shift arm (2) from projection A of the ribbon guide (3).
3. Remove the two printhead mounting screws.
4. Lift the printhead from the printer. As you lift the printhead, the ribbon guide can be removed.

P/N 53056002 Guide: Ribbon (Color) [RSPL B.2.13](#) 

P/N 50605701 Post: Ribbon Guide (Color) [RSPL B.2.13](#) 

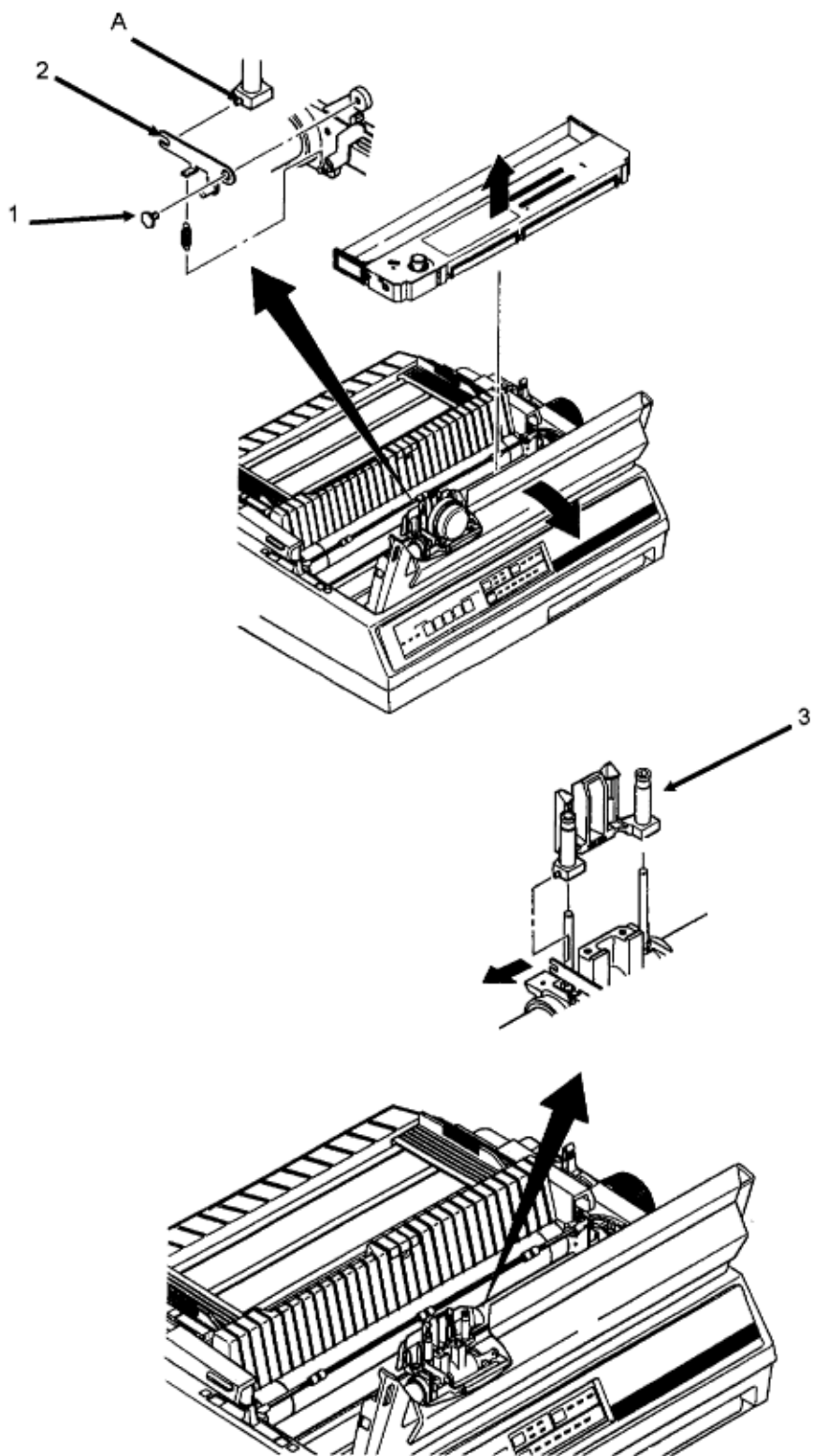

Partner Exchange (BPX) for any updates to this material. (<http://bpx.okidata.com>)

3.2.26 Bail Open Cam and Bail Open Gear

1. Remove the printer mechanism ([3.2.08](#) ).
2. Detach the E snap ring (1).
3. Remove the bail open gear (2).
4. Remove the bail open cam (3).
5. Remove the plastic ring (4).

Caution:*Installation*

When installing, make sure that the plastic ring is positioned against the rim on the bail open cam.

Installation may be easier if the bail open cam is installed on the shaft first, followed by the bail open gear.

Press down on the spring (5) slightly when installing the cam and ring.

The plastic ring MUST rest against the spring.

[P/N 50911001 Spring: Brake - B \(Color\) RSPL B.2.10](#) 

[P/N 51222601 Cam: Bail Open \(Color\) RSPL B.2.10](#) 

[P/N 51214601 Gear: Bail Open \(Color\) RSPL B.2.10](#) 

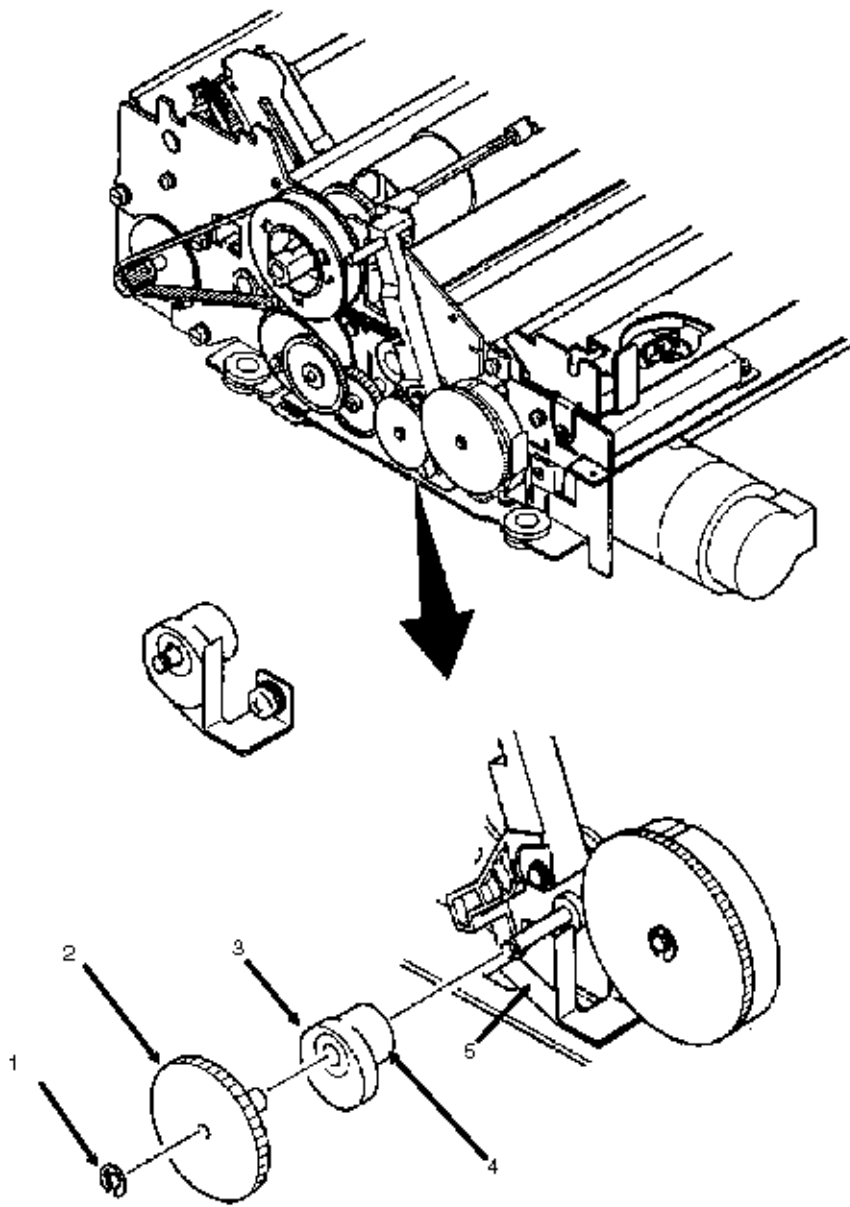

Copyright 1997, Okidata, Division of OKI America, Inc. All rights reserved. See the OKIDATA Business Partner Exchange (BPX) for any updates to this material. (<http://bpx.okidata.com>)

3.2.27 Ribbon Shift Cam and Ribbon Shift Gear

1. Remove the printer mechanism ([3.2.08](#) ).
2. Detach the E snap ring (1).
3. Remove the ribbon shift gear (2).
4. Remove the washer.
5. Remove the ribbon shift cam (3).

NOTE:*Installation*

Hold back the spring (4) while pushing the gear and cam on the shaft.

Place the roller (5) in the groove (6) of the ribbon shift cam.

Perform the color adjustment. Refer to Section 3.3  of this Service Handbook.

P/N 50910901 Spring: Brake - A RSPL B.2.10 B.2.10 

P/N 51222501 Cam: Ribbon Shift (Color) RSPL B.2.10 B.2.10 

P/N 51215101 Gear: Ribbon Shift (Color) RSPL B.2.10 B.2.10 

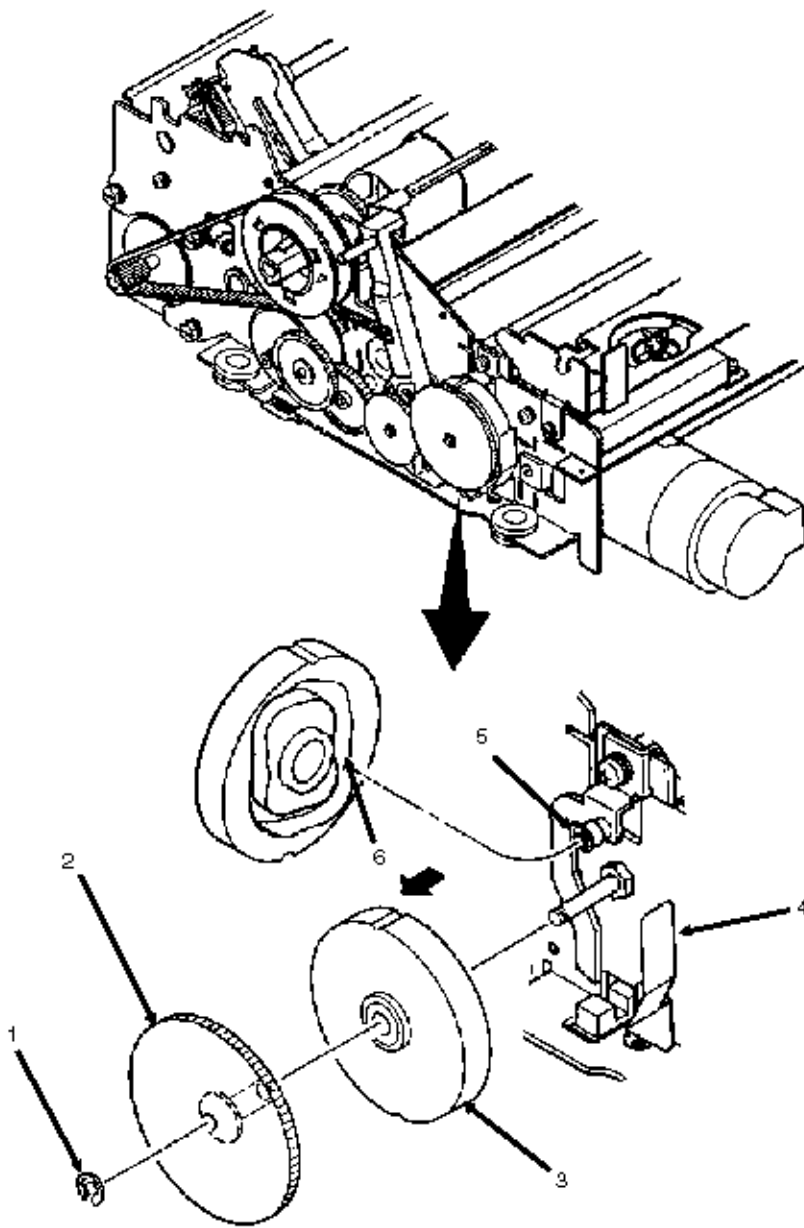

Copyright 1997, Okidata, Division of OKI America, Inc. All rights reserved. See the OKIDATA Business Partner Exchange (BPX) for any updates to this material. (<http://bpx.okidata.com>)

3.2.28 Ribbon Shift Cam Lever Assembly

1. Remove the printer mechanism [\(3.2.08 !\[\]\(cf5be311f7b2821912d8009884508fa2_img.jpg\)](#)).
2. Remove the ribbon shift cam and ribbon shift gear [\(3.2.27 !\[\]\(9804e70d96ff9fe9899b264c06a33cd7_img.jpg\)](#)).
3. Remove the mounting screw (1)
4. Detach the ribbon shift cam lever (2) from the cartridge bracket (3).

NOTE:

Installation

Perform the color adjustment. Refer to Section 3.3 of  this Service Handbook.

P/N 50054701 Lever: Shift Cam (Color) RSPL B.2.10 

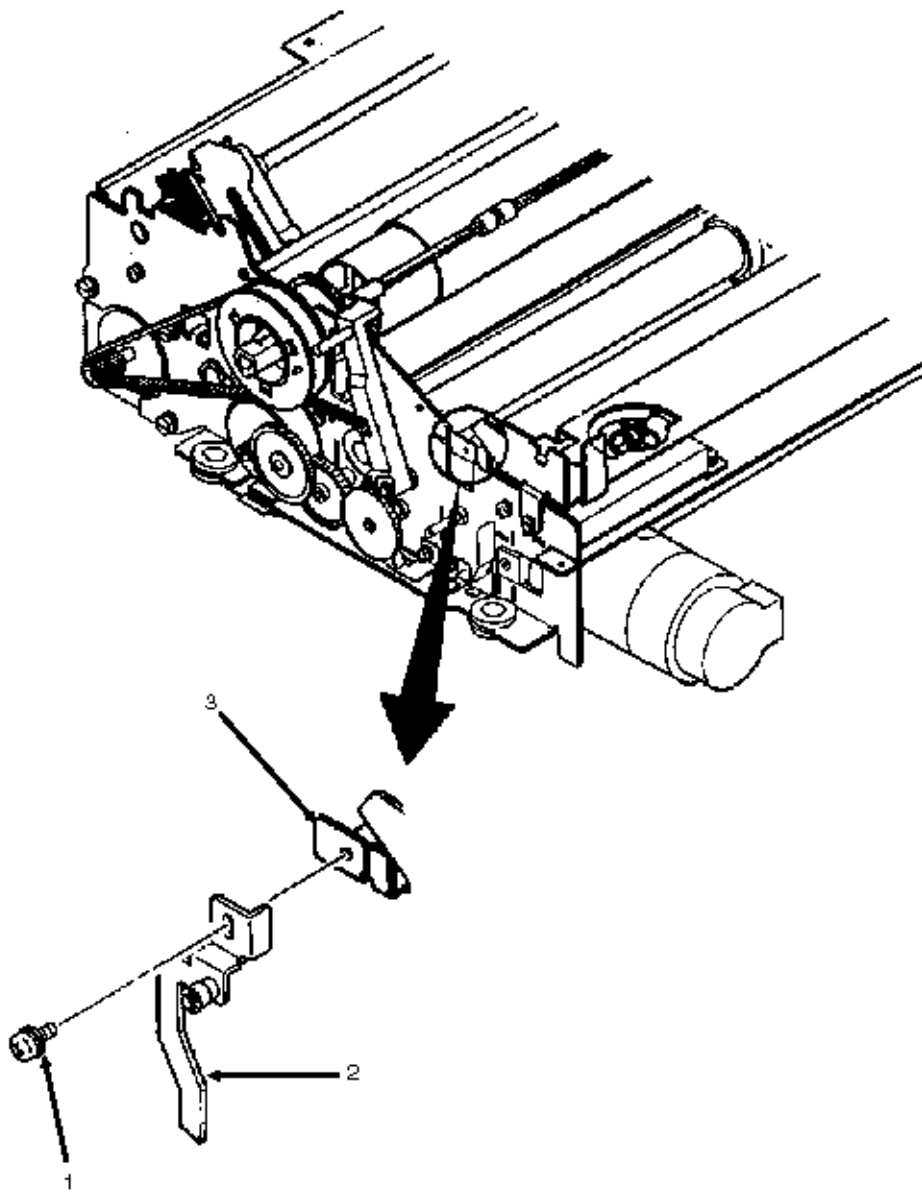

Copyright 1997, Okidata, Division of OKI America, Inc. All rights reserved. See the OKIDATA Business Partner Exchange (BPX) for any updates to this material. (<http://bpx.okidata.com>)



Sections **3.2.29** through **3.2.35** apply to the **CUT SHEET FEEDER - OPTION**

Copyright 1997, Okidata, Division of OKI America, Inc. All rights reserved. See the OKIDATA Business Partner Exchange (BPX) for any updates to this material. (<http://bpx.okidata.com>)

3.2.29 Friction Sheet

1. Power OFF the printer.
2. Remove the cut sheet feeder.
3. Remove the sheet supporter (1).
4. Move the paper lock lever (2) towards the back.
5. Remove the friction sheets (5) from the sheet guide A (3) and sheet guide B (4).

NOTE:*Installation*

When installing new friction sheets, remove the peel-off backing.

Place the sheets on the sheet guides.

[P/N 70010601 Cut Sheet Feeder 3001 Single Bin Option B.2.14](#) 

[P/N 70010701 Cut Sheet Feeder 3002 Dual Bin Option B.2.14](#) 

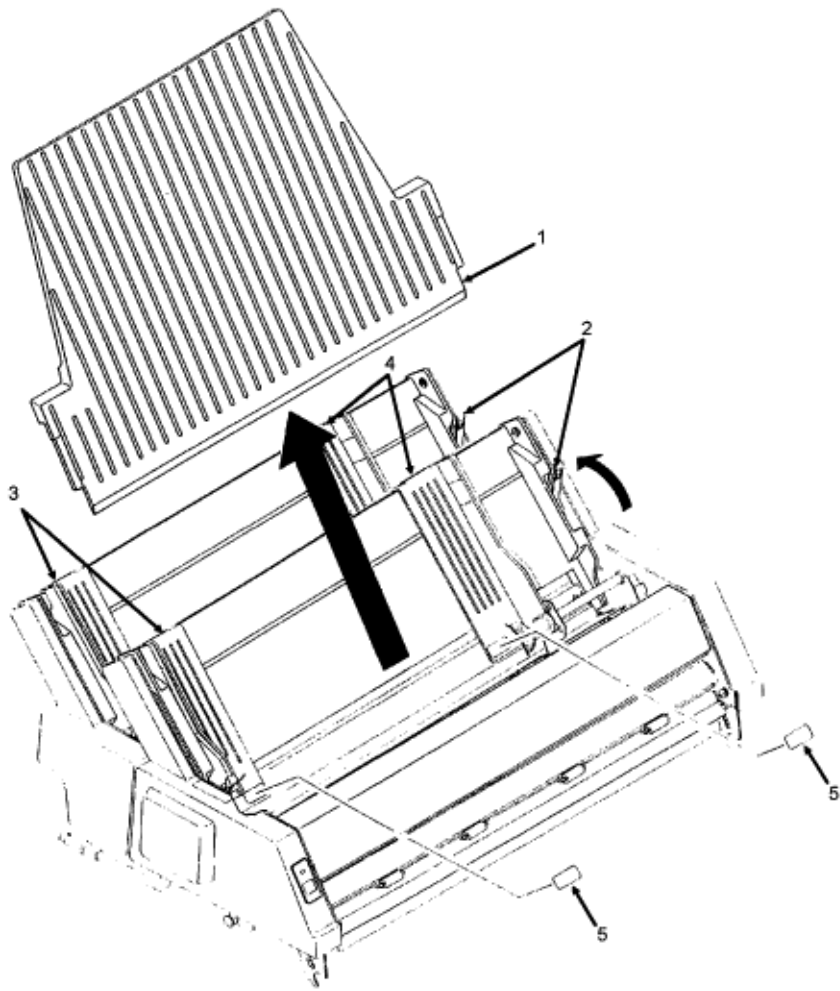

Copyright 1997, Okidata, Division of OKI America, Inc. All rights reserved. See the OKIDATA Business Partner Exchange (BPX) for any updates to this material. (<http://bpx.okidata.com>)

3.2.30 Rear Bin

6. Power OFF the printer.
7. Remove the cut sheet feeder.
8. Remove the front sheet supporter (1).
9. Remove the rear sheet supporter (2).
10. Use a screwdriver (5) to push the lock levers (6) in the direction of arrow A. The levers are inside the left side cover (3) and right side cover (4) of the rear-bin unit (10).
11. Move the rear-bin unit (11) in the direction of arrow D to disengage the lock plate (8) from the post (7) on the front bin unit (10).
12. Lift the rear-bin unit (11) in the direction of arrow C and pull in the direction of arrow D to disengage the lock plate (8) from the post (9) on the front bin unit (10). The rear-bin unit (11) will disengage from the front-bin unit (10).

NOTE:*Installation*

Engaging the front-bin unit to the rear-bin unit.

Keep the lock plate (8) on the post (9).

Press the rear-bin unit (11) against the front-bin unit (10).

The lock lever (6) will engage with the post (7).

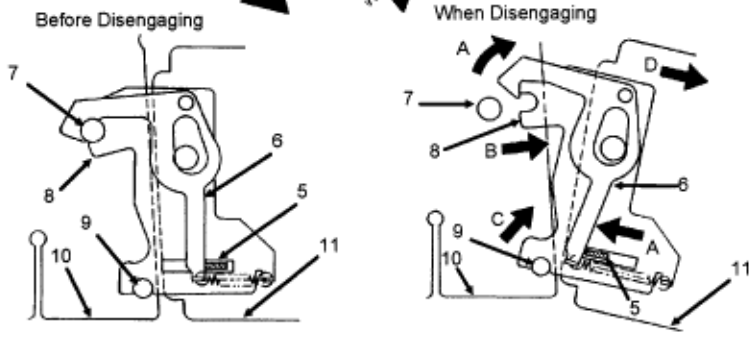
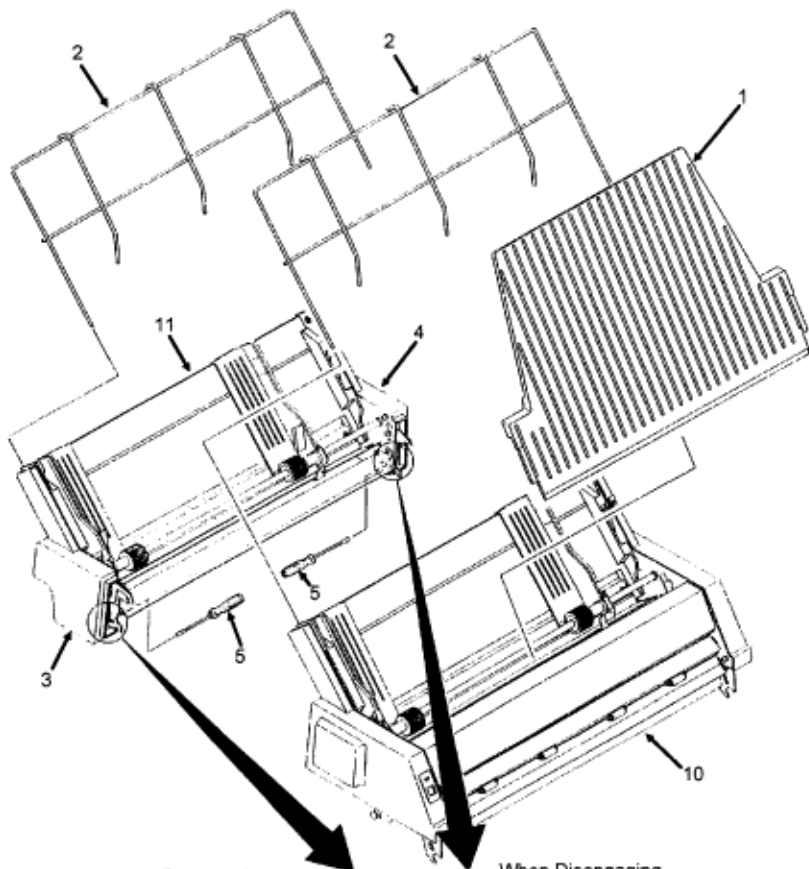

Copyright 1997, Okidata, Division of OKI America, Inc. All rights reserved. See the OKIDATA Business Partner Exchange (BPX) for any updates to this material. (<http://bpx.okidata.com>)

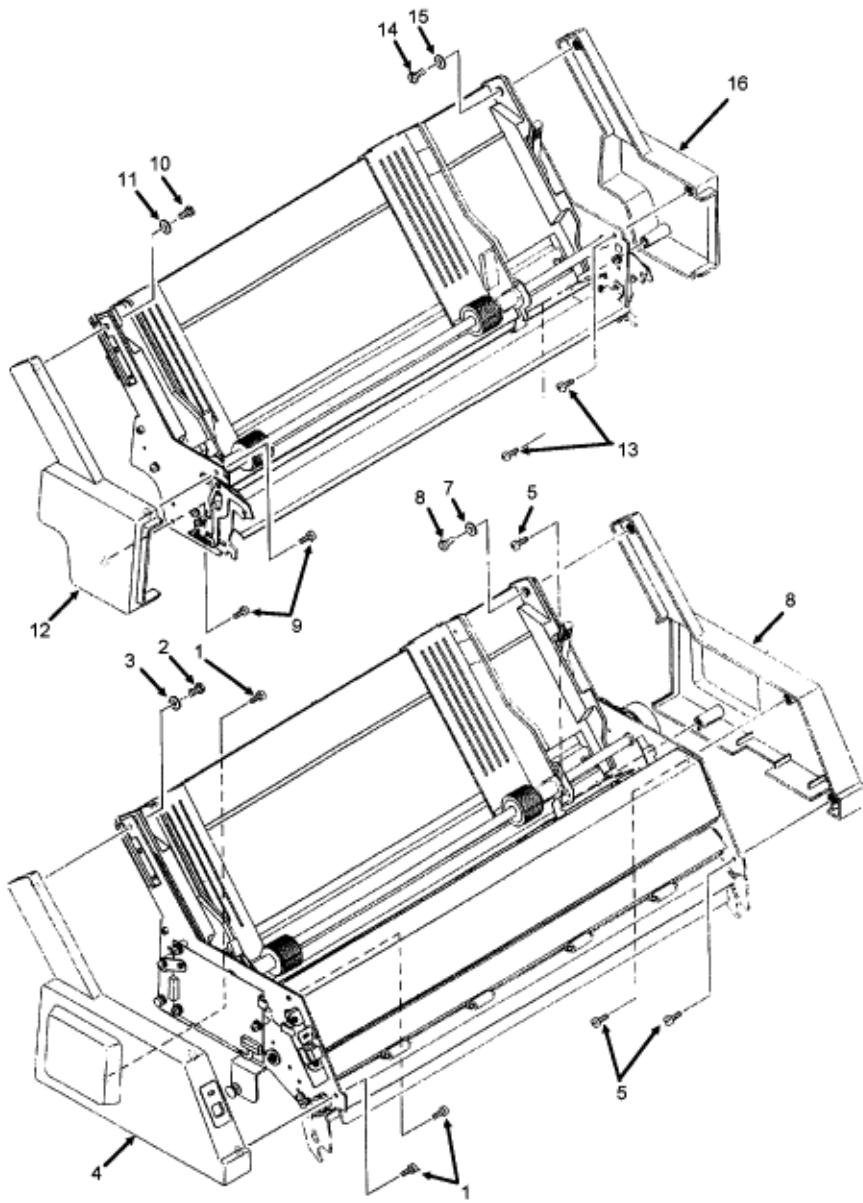

3.2.31 Side Cover

1. Power OFF the printer.
2. Remove the cut sheet feeder.
3. Disengage the rear-bin unit from the front-bin unit ([3.2.30](#) ).
4. Remove the three screws (1).
5. Remove the bolt (2).
6. Remove the collar (3).
7. Remove the left side cover (4) of the front-bin unit.
8. Remove the three screws (5).
9. Remove the bolt (6).
10. Remove the collar (7).
11. Remove the right side cover (8) of the front-bin unit.
12. Remove the two screws (9).
13. Remove the bolt (10).
14. Remove the collar (11).
15. Remove the left side cover (12) of the rear-bin unit.
16. Remove the two screws (13).
17. Remove the bolt (14).
18. Remove the collar (15).
19. Remove the left side cover (16) of the rear-bin unit.



Copyright 1997, Okidata, Division of OKI America, Inc. All rights reserved. See the OKIDATA Business Partner Exchange (BPX) for any updates to this material. (<http://bpx.okidata.com>)

3.2.32 Roller Supports and Rollers (H)

1. Power OFF the printer.
2. Remove the cut sheet feeder.
3. Disengage the rear-bin unit from the front-bin unit (3.2.30 ).
4. Remove the left and right side covers from the front and rear bin units (3.2.31 ).
5. Remove the three screws (2).
6. Slide the control board (3) in the direction of arrow A. [Single-bin units ONLY]
7. Remove the E-shaped snap ring (4).
8. Pull the hopper shaft (5) in the direction of arrow B.
9. Remove the left roller support (6).
10. Remove the right roller support (7).
11. Remove the roller H (8). The collar (9) will also be removed at the same time.
12. Remove the rollers H (8) from the left roller support (6) and the right roller support (7).

NOTE:*Installation*

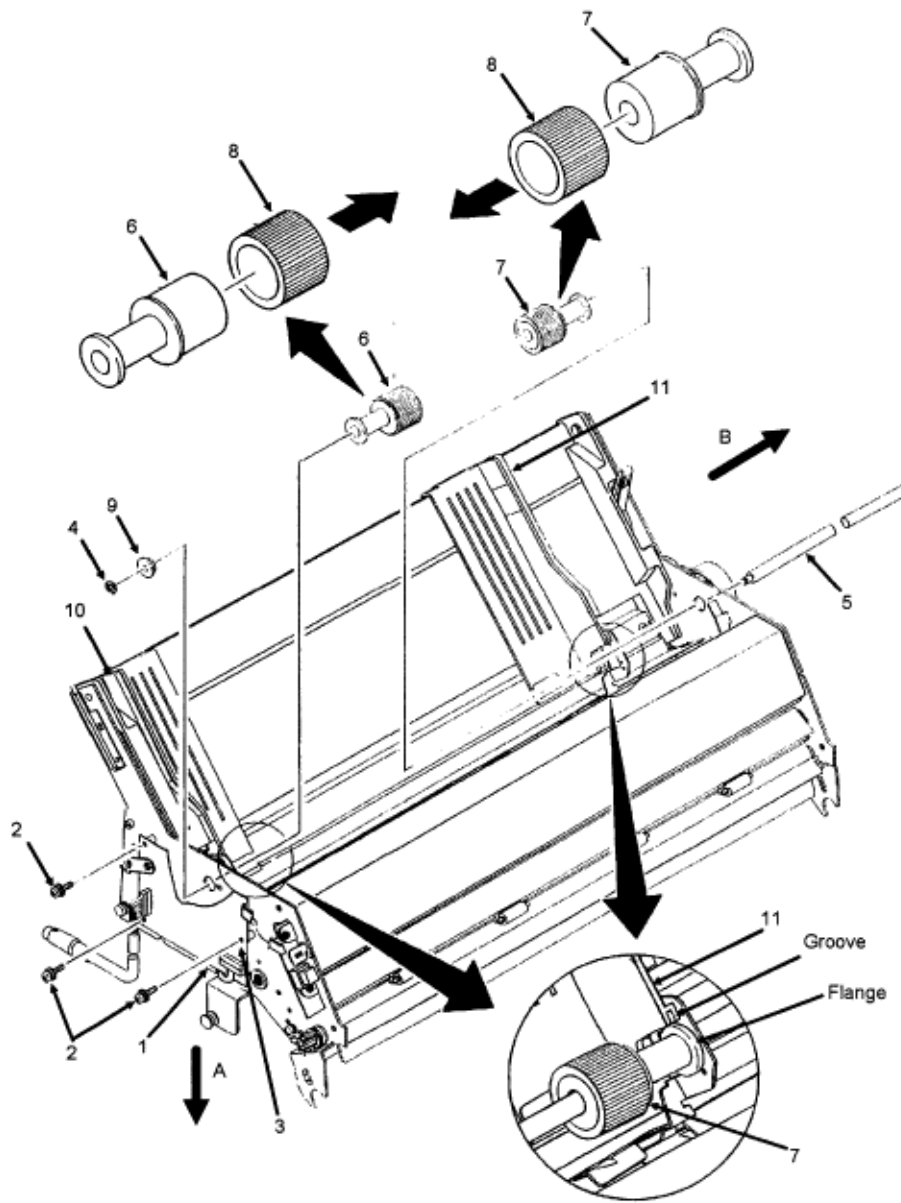

When installing the roller support bearings, be sure to install the blue side on the right and the white side on the left.

When installing the hopper shaft (5), fit the flanges of the left roller support (8) and right roller support (7) into the grooves of the sheet guide A (10) and sheet guide B (11).





Copyright 1997, Okidata, Division of OKI America, Inc. All rights reserved. See the OKIDATA Business Partner Exchange (BPX) for any updates to this material. (<http://bpx.okidata.com>)

3.2.33 Control Board

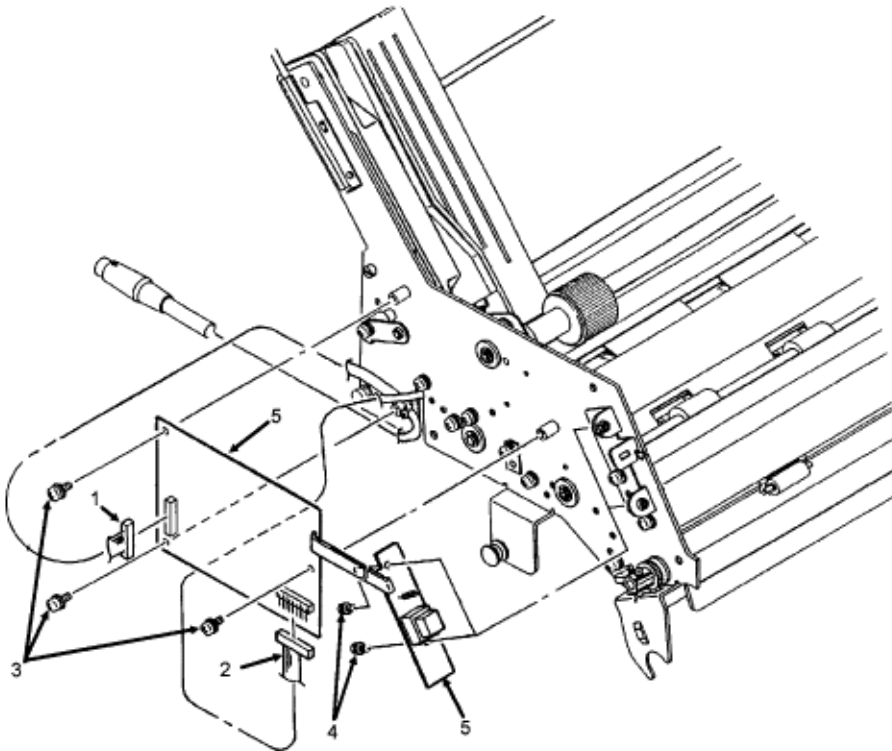
1. Power OFF the printer.
2. Remove the cut sheet feeder.
3. Disengage the rear-bin unit from the front-bin unit (3.2.30 ).
4. Remove the left side cover from the front bin unit (3.2.31 ).
5. Disconnect connectors CN1 (1) and CN2 (2).
6. Remove the three screws (3).
7. Remove the two screws (4).
8. Remove the control board (5).



3.2.34 Connection Cord

1. Power OFF the printer.
2. Remove the cut sheet feeder.
3. Disengage the rear-bin unit from the front-bin unit (3.2.30 ).
4. Remove the left side cover from the front bin unit (3.2.31 ).
5. Disconnect connector CN1 (2) from the control board (1).
6. Remove the three screws (3).
7. Remove the control board (1).
8. Cut the tie wrap (4).
9. Remove the connection cord (6) from the post (5).

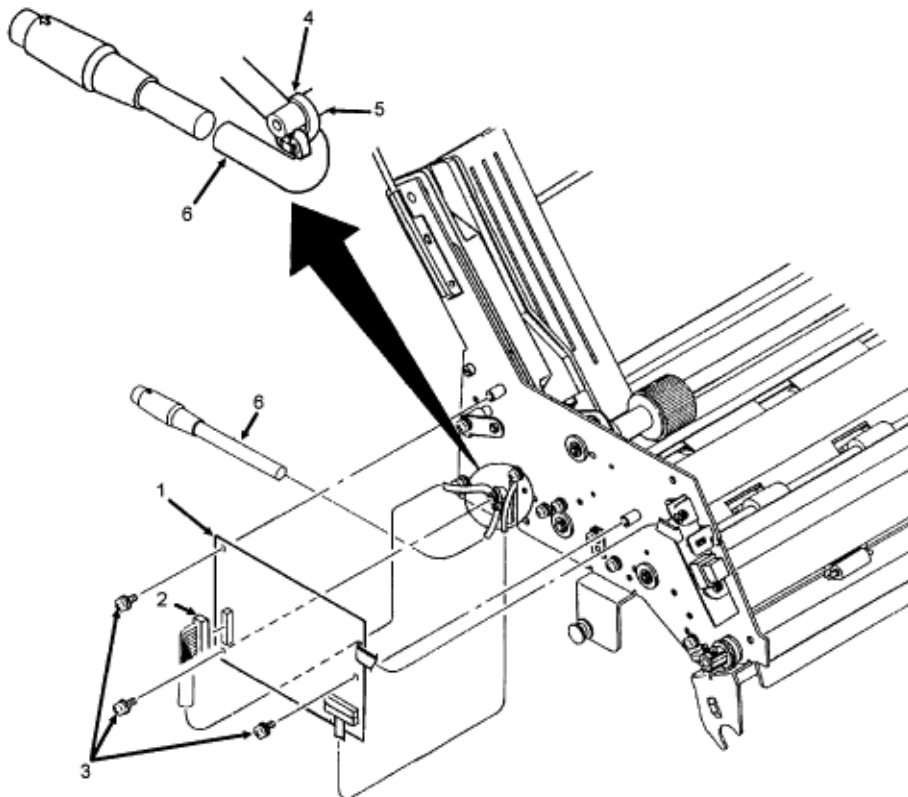

NOTE:*Installation*

Use a new tie wrap when installing the connection cord.



Copyright 1997, Okidata, Division of OKI America, Inc. All rights reserved. See the OKIDATA Business Partner Exchange (BPX) for any updates to this material. (<http://bpx.okidata.com>)

3.2.35 Motor Assembly

1. Power OFF the printer.
2. Remove the cut sheet feeder.
3. Disengage the rear-bin unit from the front-bin unit **(3.2.30 )**.
4. Remove the left and right side covers from the front bin unit **(3.2.31 )**.
5. Remove the control board **(3.2.33 )**.
6. Remove the four screws (1).
7. Remove the right sheet guide assembly (2).
8. Pull out the connection cord (4) from the groove (A) in the side frame (3).
9. Unbend the three cable clamps (5) to release the connection cord (4).
10. Remove the two screws (6).
11. Remove the motor assembly (7).
12. Remove the idle gear (8).

NOTE:*Installation*

Use a new tie wrap when installing the connection cord.

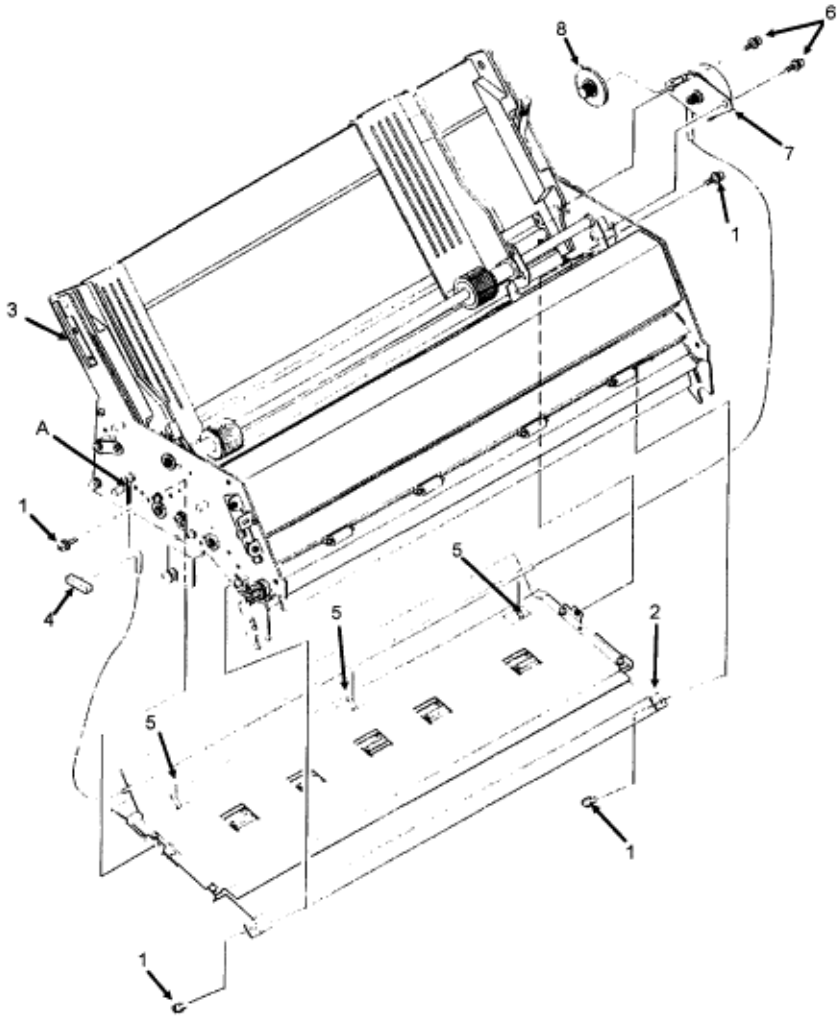

3

Copyright 1997, Okidata, Division of OKI America, Inc. All rights reserved. See the OKIDATA Business Partner Exchange (BPX) for any updates to this material. (<http://bpx.okidata.com>)



3.3 PRINTER ADJUSTMENTS

3.3.01 General Information

This section contains the procedures for performing adjustments on the printer. These procedures may be required when replacing either consumables or parts. The disassembly/assembly procedures list the required adjustments and refer you to this section. Failure to perform these procedures may result in unnecessary service calls.

Copyright 1997, Okidata, Division of OKI America, Inc. All rights reserved. See the OKIDATA Business Partner Exchange (BPX) for any updates to this material. (<http://bpx.okidata.com>)

3.3.02 Printhead Gap Adjustment

General Information

Before performing this adjustment, always verify that the printhead is properly installed.

Perform the printhead gap adjustment procedure when any of the following occur.

Poor Print Quality

Uneven Print Quality (darker on one side of the document).

Excessive wear on the printhead or platen

Parts are replaced

Printhead [\(3.2.01 !\[\]\(4fe57c3593bf1b21d272ae7ac8dfaf77_img.jpg\)](#))

Platen Assembly [\(3.2.09 !\[\]\(0d5ec72f61334709c3fc9450209b754f_img.jpg\)](#))

Space Motor Assembly [\(3.2.14 !\[\]\(b792654f2cef9719eabeb6c5be00811e_img.jpg\)](#))

Carriage Shaft [\(3.2.18 !\[\]\(7d1d6890825e83a6a4a51febe2dcc7f3_img.jpg\)](#))

NOTE:

Place a new ribbon cartridge in the printer before testing.

Procedure

1. Remove the printhead [\(3.2.01 !\[\]\(1fd18b524d5424e49d618cba18b5cf0d_img.jpg\)](#))
2. Remove the ribbon guide [\(3.2.02 !\[\]\(7462404f68a272b27cdfb7ddb881c55b_img.jpg\)](#)).
3. Remove the ribbon protector [\(3.2.03 !\[\]\(7e8076cb91acf7af6780e8527ba40e6f_img.jpg\)](#)).
4. Install the printhead.
5. Set the printhead gap lever to position 1.
6. Set the paper release lever to the OPEN position.
7. Loosen the left and right eccentric collar setscrews.

STEP A

8. Place the printhead at the left side of the platen.
9. Rotate the left adjusting collar until you obtain a .017" (+/- .001") gap between the printhead and the platen.
10. Place the printhead at the right side of the platen.
11. Rotate the right adjusting collar until you obtain a .017" (+/- .001") gap between the printhead and the platen.
12. When the correct gap has been attained, tighten the left and right eccentric collar setscrews.

13. Check the gap at the left side, center and right side of the platen. If the printhead gap is not within specification, go to STEP A.
14. Remove the printhead.
15. Install the ribbon protector, ribbon guide and printhead.

CAUTION:

Be sure to pull the printhead toward the stopper whenever it is installed.

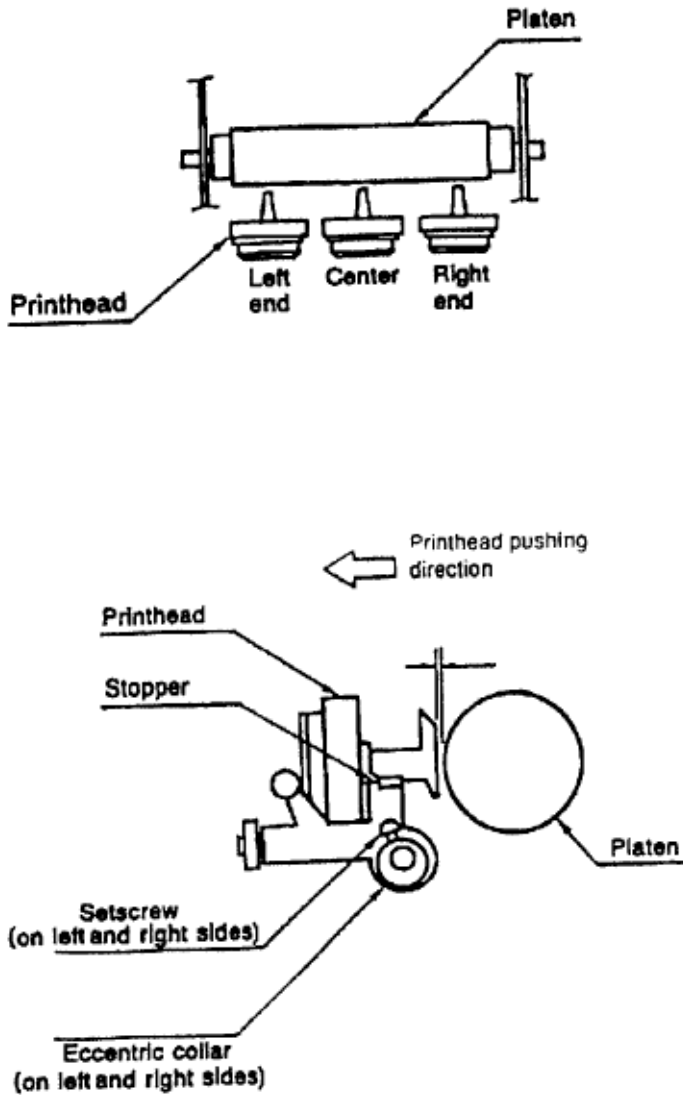

3.3.03 Line Feed Belt Tension

General Information

Perform the line feed belt tension adjustment when any of the following occur.

Erratic line spacing occurs

Parts are replaced

Line Feed Belt (3.2.09 ).

Procedure

1. Rotate the platen pulley at least once before making the adjustment
2. Loosen the three line feed motor mounting bolts (1).
3. Using a tension gauge, apply .5 pound of pressure at point A.
4. Adjust the line feed motor (2) position to obtain a 1 /16 inch deflection at point B.
5. Tighten the three mounting bolts.

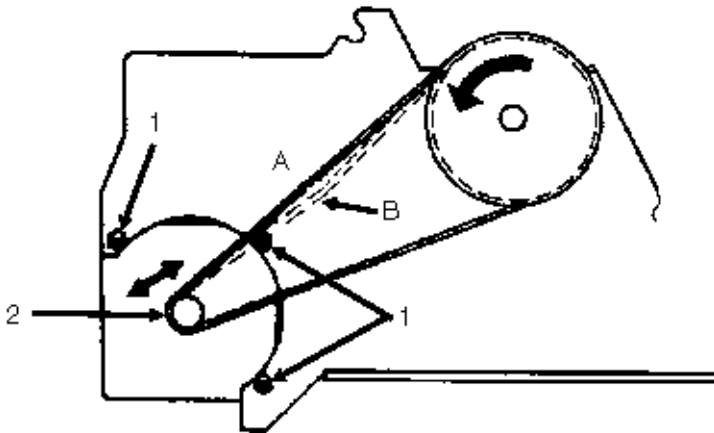

3.3.04 Color Adjustment (Microline 393C-Plus Printer)

General Information

Perform the color adjustment when any of the following occur.

Colors "bleed" into one another

Parts are replaced

Ribbon Shift Cam and Ribbon Shift Gear [\(3.2.27\)](#)

Ribbon Shift Cam Lever Assembly [\(3.2.28\)](#)

Procedure: Ribbon Home Adjustment

1. Remove the upper cover assembly [\(3.2.04\)](#).
2. Remove the printer mechanism [\(3.2.08\)](#).
3. Rotate the ribbon shift cam (1) so the ribbon guide (2) is at the top of the post (3).
4. The gap from the end face of the ribbon sensor (4) to the shift cam lever (5) must be .020 inches.
5. If adjustment is necessary, loosen the shift cam lever mounting screw (6) and position the lever to obtain the desired clearance.
6. Check that the ribbon guide remained at the top of the post. If it moved, repeat the procedure.

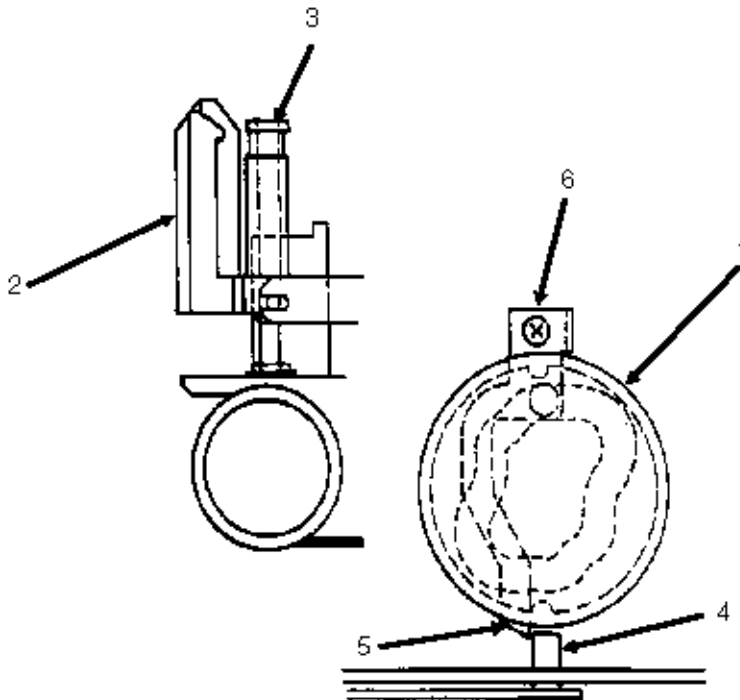

Copyright 1997, Okidata, Division of OKI America, Inc. All rights reserved. See the OKIDATA Business Partner Exchange (BPX) for any updates to this material. (<http://bpx.okidata.com>)

3.3.05 Key Combinations

Key Combination	Function
SELECT + FORM FEED (Hold during power ON)	Activates Hexadecimal Dump Mode
SELECT + PARK/TOF (Hold during power ON)	Resets Printer Menu to factory defaults
LINE FEED (Hold during power ON)	Activate Font Test To end Font Test press SELECT
QUIET (Press with printer deselected / OFF-LINE)	Activate Menu To exit press SELECT
PARK/TOF (Hold during power ON)	Activate Rolling ASCII Test To end Rolling ASCII Test press SELECT

3.3.06 Menu Operation

General Information

The menu is used to customize the printers settings and features.

The Menu is made up of a number of Groups.

Each Group has a list of Items.

Each Item has several Settings.

Copyright 1997, Okidata, Division of OKI America, Inc. All rights reserved. See the OKIDATA Business Partner Exchange (BPX) for any updates to this material. (<http://bpx.okidata.com>)



Service Guide ML393/ML393CPlus

Chapter 3 Maintenance

Menu Mode

CAUTION:

If the Menu is set for wide paper, and narrow paper is used, the printhead will print on the platen. This could damage / destroy the printhead, platen, and ribbon.

To place the printer in the Menu Mode, follow this procedure.

1. Verify that continuous feed paper is installed.
2. Verify that the ribbon is correctly installed.
3. Verify that the width of the installed paper matches the paper width menu setting.
4. Press SELECT and place the printer OFF-LINE (SELECT will *NOT* be lit).
5. Press QUIET to enter Menu Mode.
6. The line shown below will print.

Font Print Quality LQ

7. Go to Step A to print the current menu.

Go to Step B to change the menu.

Step A

Press PRINT to print the current Menu.

Press EXIT to exit Menu Mode.

The printer will go ON-LINE. (SELECT will light.)

Step B

When the printer is in Menu Mode, the functions shown below the switches on the operator panel are active.

Press GROUP to move through the groups of the Menu. A line prints, showing the Group.

Press ITEM to move through the items in a group. A line prints, showing the Item.

Press SET to change the setting for an item. A line prints, showing the Setting.

Press EXIT to save any changes and exit Menu Mode.

The printer will go ON-LINE. (SELECT will light.)



Service Guide ML393/ML393CPlus

Chapter 3 Maintenance

Menu Print

1. Verify that paper and the ribbon are installed.
 2. Power ON the printer.
 3. Press SELECT and place the printer OFF-LINE (SELECT will *not* be lit).
 4. Press QUIET to enter Menu Mode.
 5. The line shown below will print.
Font Print Quality LQ
 6. Press PRINT to print the current Menu.
 7. Press EXIT to save any changes and exit Menu Mode.
 8. The printer will go ON-LINE. (SELECT will light.)
-

Copyright 1997, Okidata, Division of OKI America, Inc. All rights reserved. See the OKIDATA Business Partner Exchange (BPX) for any updates to this material. (<http://bpx.okidata.com>)



Service Guide ML393/ML393CPlus

Chapter 3 Maintenance

Sample Menu

```

MENU MODE

Font          Print Quality      HSD
Font          Typestyle         Courier
Font          Pitch           10 (PI)
Font          Style           Normal
Font          Size            Single
Font          Smoothing       No

General Control Emulation Mode      EPSON 1Q
General Control Graphics          Uni-directional
General Control Paper Out Override No
General Control Print Registration 0
General Control Operator Panel Functions Full Operation
General Control Page Width        13.6"
General Control Ribbon Selection   Film Ribbon
General Control Reset Inhibit     Valid
General Control Paper/Transparency Paper

Vertical Control Line Spacing      6 LPI
Vertical Control Form Tear Off    Off
Vertical Control Skip Over Perforation No
Vertical Control Auto LF          No
Vertical Control Auto CR          No
Vertical Control Page length      11"
Vertical Control Cut Sheet Page Length 11"

Symbol Sets   Character Set      EPSON
Symbol Sets   Code Page          USA
Symbol Sets   Language Set       American
Symbol Sets   Zero Character      Slashed

General Interface Max Receive Buffer  8K
General Interface Print Suppress Effective Yes
General Interface Auto-Feed XT Signal Valid
General Interface CPU Compensation Standard

Serial Interface Parity              None
Serial Interface Serial Data 7/8 Bits 8
Serial Interface Protocol            1-ON/X-OFF
Serial Interface Diagnostic Test     No
Serial Interface Busy Line          STD
Serial Interface Baud Rate           9600 BPS
Serial Interface DSR Signal          Invalid
Serial Interface DTR Signal          Ready on Power Up
Serial Interface Busy Time           200 ms

Font          Print Quality      HSD

MENU END

```



Service Guide ML393/ML393CPlus

Chapter 3 Maintenance

Menu Settings

Factory default settings are printed in ***Bold Italic***.

Group	Item	Setting
Font	Print Quality	<i>LQ</i> NLQ Utility HSD
	Typestyle	<i>Courier</i> Roman Helvette Orator Cartridge DLL
	Pitch	<i>10 cpi</i> 12 cpi 15 cpi 17.1 cpi 20 cpi Proportional
	Style	<i>Normal</i> Italics
	Size	<i>Single</i> Double Triple
	Smoothing	<i>No</i> Yes
General Control	Emulation Mode	<i>Epson LQ</i> IBM PPR IBM X24 AGM
	Graphics	Bi-directional <i>uni-directional</i>
	Paper Out Override	<i>No</i> Yes
	Print Registration	+5 +4 +3 +2 +1 <i>0</i> -1 -2 -3 -4 -5
	Operator Panel Functions	<i>Full Operation</i> Limited Operation
	Page Width	<i>13.6"</i> 8"
	Ribbon Selection	Microline 393C-Plus Black Yellow <i>Magenta</i> Cyan Violet Orange Green
		Microline 393-Plus <i>Black Ribbon</i> Film Ribbon
	Reset Inhibit	<i>Valid</i> Invalid
	Paper / Transparency	<i>Paper</i> Transparency

Factory default settings are printed in ***Bold Italic***.

Group	Item	Setting
-------	------	---------

Vertical Control	Line Spacing	6 LPI 8 LPI
	Form Tear Off	Off 300 mS 1 sec 2 sec
	Skip Over Perforation	No Yes
	Auto LF	No Yes
	Auto CR	No Yes
	Page Length	3" 3.5" 4" 5.5" 6" 7" 8" 8.5" 11" 11 2/3" 12 14" 17"
Symbol Sets	Character Set	IBM Set I IBM Set II Epson
	Language Set	American French German British Danish I Swedish Italian Spanish I Japanese Norwegian Danish II Spanish II Latin American French Canadian Dutch Publisher
	Zero Character	Slashed Unslashed
General Interface	Max. Receive Buffer	1 Line 8 K 23 K 40 K (Optional)
	Print Suppress Effective	No Yes
	Auto Feed XT	Invalid Valid
Serial Interface	Parity	None Odd Even
(Appears ONLY when serial interface is in use)	Serial Data 7/8 Bits	8 Bits 7 Bits
	Protocol	Ready / Busy X-ON / X-OFF
	Diagnostic Test	Yes No
	Busy Line	SSD- SSSD+ DTR RTS
	Baud Rate	19200 bps 9600 bps 4800 bps 2400 bps 1200 bps 600 bps 300 bps
	DSR Signal	Valid Invalid
	DTR Signal	Ready on Power UP Ready on Select
	Busy Time	200 mS 1 sec



Service Guide ML393/ML393CPlus

Chapter 3 Maintenance

Menu Reset

CAUTION:

Once the menu has been reset, all customized menu settings WILL BE LOST.

ALWAYS print the menu BEFORE resetting the printer to factory defaults.

To reset the menu to factory default settings, follow this procedure.

1. Print the Menu.

When the menu is reset, ALL customized settings ARE LOST.

Printing the Menu provides a reference of customized settings.

2. Power OFF the printer.

3. Press SELECT and TOF while powering ON the printer.

4. The Menu is reset to Factory Defaults.

Copyright 1997, Okidata, Division of OKI America, Inc. All rights reserved. See the OKIDATA Business Partner Exchange (BPX) for any updates to this material. (<http://bpx.okidata.com>)



Service Guide ML393/ML393CPlus

Chapter 3 Maintenance

Limited Operation

General Information

The Operator Panel Functions Item in the Printer Menu can be set to either Full Operation or Limited Operation. If the printer is part of a customized system or if it is used by different operators, a system manager may be using this feature to maintain proper print settings.

FONT, PRINT QUALITY, and CHARACTER PITCH (on the operator panel) do not work when the printer is set for Limited Operation.

Procedure

CAUTION:

Check with the system manager BEFORE changing the setting for the operator panel function!

1. Verify that paper is loaded and that the ribbon is installed.
 2. Power OFF the printer.
 3. Press and hold QUIET while powering ON the printer.
 4. Press GROUP until GENERAL CONTROL prints.
 5. Press ITEM until OPERATOR PANEL FUNCTIONS prints.
 6. Press SET until FULL OPERATION prints.
 7. Press EXIT to save any changes and exit Menu Mode.
 8. The printer will go ON-LINE. (SELECT will light.)
-



Service Guide ML393/ML393CPlus

Chapter 3 Maintenance

3.3.07 Top of Form

General Information

Top of form is the distance from the top edge of the paper to the first print position on the page.

The red line on the ribbon protector indicates the baseline of the Top of Form.

When the printer advances paper to the next page, it stops at the top of form.

Procedure: Setting Top of Form

1. Load paper into the printer by pressing FORM FEED.
 2. Press SELECT until the printer is OFF-LINE. (SELECT will NOT be lit).
 3. The red line on the plastic ribbon protector indicates the base of the printing line. Use this red line as a guide.
 4. Press and hold PARK while pressing one of the two switches listed below.
FORM FEED advances the paper. The space used for the Top of Form increases.
LINE FEED retracts the paper. The space used for the Top of Form decreases.
 5. Release PARK.
 6. Press SELECT and place the printer ON-LINE. (SELECT will be lit).
-

Copyright 1997, Okidata, Division of OKI America, Inc. All rights reserved. See the OKIDATA Business Partner Exchange (BPX) for any updates to this material. (<http://bpx.okidata.com>)

3.3.08 Paper Park

General Information

Paper park allows the user to switch from continuous feed paper to single-sheet paper without removing the continuous feed paper from the printer. The continuous feed paper will be retracted from the platen and down into the printer housing without disengaging it from the built-in tractor.

After a single-sheet paper is printed, pull the bail lever forward and the continuous feed paper will move back into the print position.

Paper park cannot be used when the optional pull tractor is installed.

Procedure: Continuous Feed to Single Sheet

1. Tear off any printed pages.
2. Make sure the printer is selected. The SELECT lamp must be lit.
3. Press PARK / TOF.
4. The paper will retract from the paper path.
5. Move the paper selection to the single sheet position (towards the back of the printer).
6. Raise the paper support to its upright position.
7. Align the left paper guide with the paper icon on the support.
8. Place a piece of paper in the paper support.
9. Position the right paper guide to accommodate the right edge of paper.
10. Press FORM FEED to feed single-sheet paper into the printer.
11. Print the single sheet.

Procedure: Single Sheet to Continuous Feed

1. Remove any single-sheet paper in the printer.
 2. Move the paper selection lever to the continuous form position (to the front of the printer).
 3. Lower the paper support.
 4. Press FORM FEED to feed continuous feed paper into the printer.
 5. The paper will advance to the loading position.
 6. Adjust the top of form (if necessary).
-



Service Guide ML393/ML393CPlus

Chapter 3 Maintenance

3.3.09 Forms Tear Off

General Information

This feature (when activated) will automatically advance continuous feed paper to the tear-off position after it finishes printing the last page in the document. A few seconds after printing stops, the printer will move the paper up to the tear-off position, aligning the perforation with the serrated edge on the access cover. The operator will be able to tear off the last printed page without wasting paper or adjusting the printer. When the printer receives data to print, it will automatically return the paper to the top of form position for printing.

Forms Tear Off can only be used with continuous feed paper fed in from the rear on the built-in push tractor. It CANNOT be used with the optional pull tractor.

NOTES:

Some programs, such as high resolution graphics packages, pause occasionally while sending data to the printer.

If the pause lasts more than the selected interval, the paper will advance to the tear-off position until more data is received.

No data is lost, but the extra paper movement causes uneven print registration.

If this problem occurs, disable (set to OFF) the Menu Setting for Forms Tear Off.

Procedure

1. Load continuous feed paper into the printer.
2. Verify that the ribbon is installed.
3. Power ON the printer.
4. Verify that the printer is ON-LINE (SELECT lamp is lit).
5. Press SELECT and place the printer OFF-LINE (SELECT will *not* be lit).
6. Press QUIET to enter Menu Mode.
7. The line shown below will print.
Font Print Quality <current setting>
8. Press GROUP until the following line is printed.
Vertical Control Emulation Mode <current setting>
9. Press ITEM until the following line is printed.
Vertical Control Form Tear Off <current setting>
10. Press SET to change the menu setting for Form Tear Off.

To activate Form Tear Off, the setting must be 300 mS, 1 sec., or 2 sec.

To deactivate Forms Tear Off, the setting must be OFF.

11. Press EXIT to save any changes and exit Menu Mode.

12. The printer will go ON-LINE. (SELECT will light.)

Copyright 1997, Okidata, Division of OKI America, Inc. All rights reserved. See the OKIDATA Business Partner Exchange (BPX) for any updates to this material. (<http://bpx.okidata.com>)

3.3.10 Resets

Menu Reset

CAUTION:

Print the menu before resetting it to factory defaults.

When the menu is reset, ALL customized settings ARE LOST.

Printing the Menu provides a reference of customized settings.

If the Menu is set for wide paper, and narrow paper is used, the printhead will print on the platen. This could damage / destroy the printhead, platen, and ribbon.

To reset place the printer in the Menu Mode, follow this procedure.

1. Verify that continuous feed paper is installed.
2. Verify that the ribbon is correctly installed.
3. Verify that the width of the installed paper matches the paper width menu setting.
4. Press SELECT and place the printer OFF-LINE (SELECT will *NOT* be lit).
5. Press QUIET to enter Menu Mode.
6. The line shown below will print.

Font Print Quality LQ

7. Press PRINT to print the current Menu.

When the menu is reset, ALL customized settings ARE LOST.

Printing the Menu provides a reference of customized settings.

8. Power OFF the printer.
9. Press TOF and SELECT while powering ON the printer.
10. The Menu is reset to Factory Defaults.



Service Guide ML393/ML393CPlus

Chapter 3 Maintenance

3.4 CLEANING

WARNING

When cleaning the printer, power OFF the printer and detach the AC power cable from the printer and the AC outlet.

3.4.01 General Information

An accumulation of paper dust is the most frequent cause of print quality problems in a dot matrix printer. Small pieces of paper can cause paper jams. A dirty platen will smudge paper. It is important to clean the printer regularly, paying particular attention to the printhead area and the paper paths.

If the lubrication procedures are not performed properly, the printer will require more frequent cleaning. Excessive lubricant attracts dust and accumulations build up quickly.

Keeping the covers in place and performing the cleaning procedures correctly will help ensure the highest quality printer output.

3.4.02 Cleaning Schedule

1. Every six months

or

2. Every 300 hours of operating time.

3.4.03 Cleaning Tools

1. Clean, soft, lint-free cloth
2. Long cotton swabs
3. All-purpose cleaner
4. Vacuum cleaner
5. Platen cleaner

3.4.04 Areas to be Cleaned

Areas to be Cleaned	Action to be Taken
Paper Paths	Vacuum and wipe up paper bits and dust.
Printer Mechanism	Vacuum paper dust
Carriage Shaft	Wipe clean with lint-free cloth
Slide Bar	Wipe clean with lint-free cloth

Ribbon Protector	Use a dry cotton swab to remove ink residue
Single Sheet Sensor	Wipe with dry cotton swab
Color Shift Sensor	Wipe with dry cotton swab
Bottom Paper-End Sensor	Wipe with dry cotton swab
Paper Bail Sensor	Wipe with dry cotton swab
Platen	Wipe clean with soft cloth and platen cleaner
Printer Cover	Clean with soft cloth and all-purpose cleaner

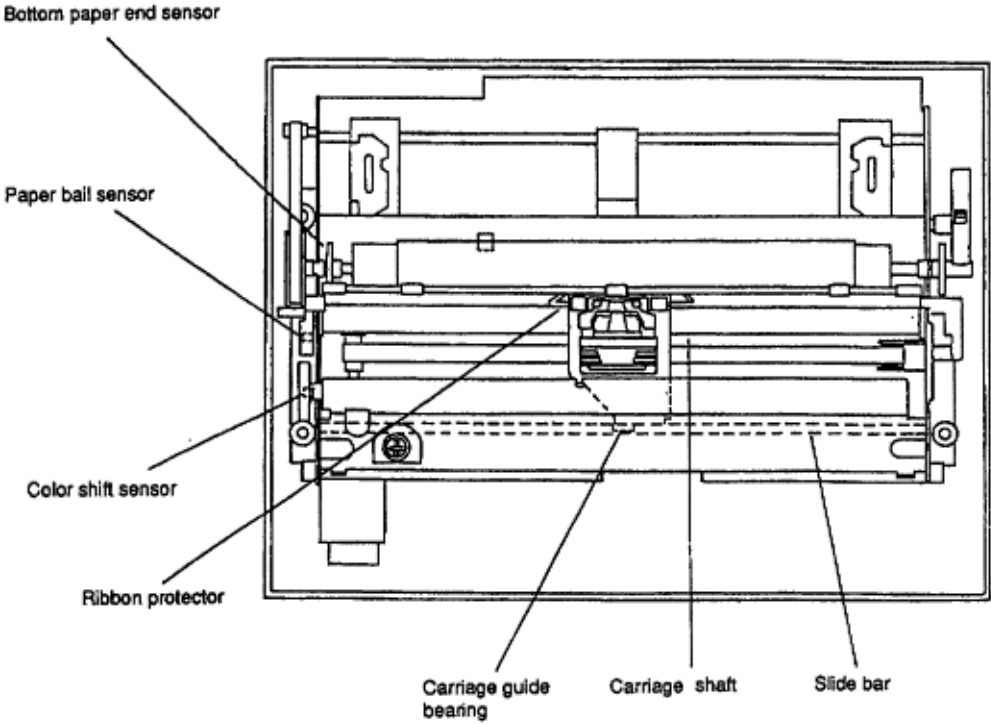

Copyright 1997, Okidata, Division of OKI America, Inc. All rights reserved. See the OKIDATA Business Partner Exchange (BPX) for any updates to this material. (<http://bpx.okidata.com>)



Service Guide ML393/ML393CPlus

Chapter 3 Maintenance

3.5 LUBRICATION

3.5.01 General Information

If the lubrication procedures are not performed properly, the printer will require more frequent cleaning. Excessive lubricant attracts dust and accumulations build up quickly. An accumulation of paper dust is the most frequent cause of print quality problems in a dot matrix printer.

When lubricating the printer, refer to the lubrication diagrams on the following pages. Each lubrication point lists a code for the type of lubricant to be used along with a code for the amount of lubricant required. These codes are defined below.

Copyright 1997, Okidata, Division of OKI America, Inc. All rights reserved. See the OKIDATA Business Partner Exchange (BPX) for any updates to this material. (<http://bpx.okidata.com>)



Service Guide ML393/ML393CPlus

Chapter 3 Maintenance

3.5.02 Lubrication Schedule

Once a year

or

Every 600 hours of operating time.

Copyright 1997, Okidata, Division of OKI America, Inc. All rights reserved. See the OKIDATA Business Partner Exchange (BPX) for any updates to this material. (<http://bpx.okidata.com>)



Service Guide ML393/ML393CPlus

Chapter 3 Maintenance

3.5.03 Lubrication Types and Amounts

Do NOT over-lubricate the printer. Operational problems are caused by excess lubricant. The excess lubricant causes dust to accumulate. These accumulations can jam gears or cause print problems.

Type	Amount	Diagram Designation
Oil	Abundant	PM- A
Machine Oil	Medium: 3 - 4 Drops	PM - B
10w-30 or equivalent	Small: 1 Drop	PM - C
Grease	Abundant	GEP - A
Alvania grease #2 EP Moly-lube grease	Medium Thin coating (.008 inches)	GEP - B
or equivalent	Small Apply and wipe off	GEP - C



Service Guide ML393/ML393CPlus

Chapter 3 Maintenance

3.5.04 Areas Not Lubricated

Lubricant should never contact the parts listed below.

Sensors

Printhead

Mini-pitch Belt

Space Belt

Ribbon

Tractor Pins

Platen Assembly (Rubber Face)

Pressure Roller (Rubber Face)

Head Cable

Space Motor Printed Circuit Board

Electrical Contacts and Connections

Teeth of the gears in the Gear Case Assembly

Copyright 1997, Okidata, Division of OKI America, Inc. All rights reserved. See the OKIDATA Business Partner Exchange (BPX) for any updates to this material. (<http://bpx.okidata.com>)

Lubrication Points (Monochrome and Color)

Left and Right Sides of Printer

Type	Amount	Diagram Designation
Oil	Abundant	PM- A
Machine Oil	Medium: 3 - 4 Drops	PM - B
10w-30 or equivalent	Small: 1 Drop	PM - C
Grease	Abundant	GEP - A
Alvania grease #2 EP Moly-lube grease	Medium Thin coating (.008 inches)	GEP - B
or equivalent	Small Apply and wipe off	GEP - C

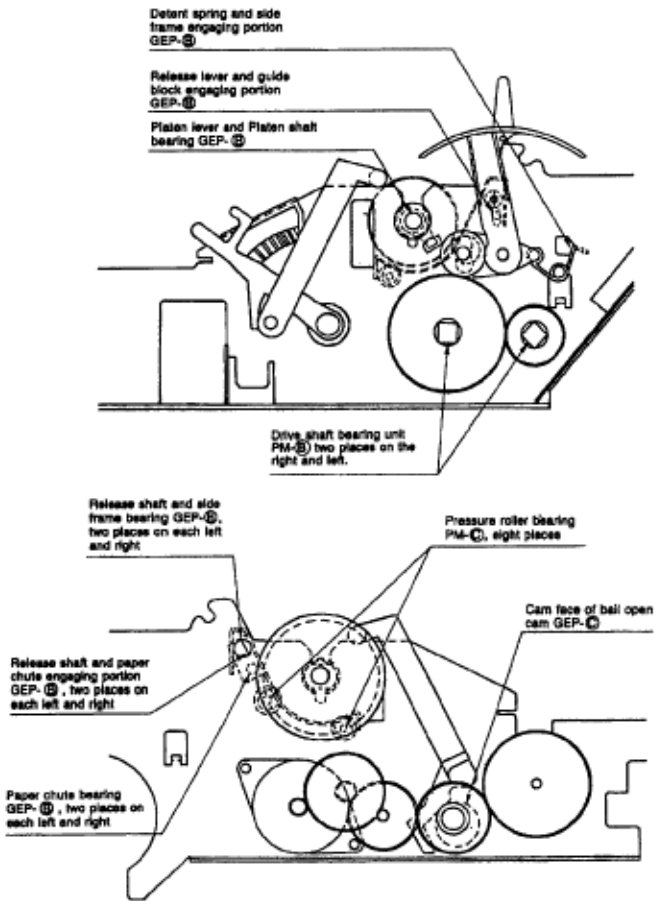

Copyright 1997, Okidata, Division of OKI America, Inc. All rights reserved. See the OKIDATA Business Partner Exchange (BPX) for any updates to this material. (<http://bpx.okidata.com>)



Service Guide ML393/ML393CPlus

Chapter 3 Maintenance

Platen, Carriage Shaft, Idle Gear

Type	Amount	Diagram Designation
Oil	Abundant	PM- A
Machine Oil	Medium: 3 - 4 Drops	PM - B
10w-30 or equivalent	Small: 1 Drop	PM - C
Grease	Abundant	GEP - A
Alvania grease #2 EP Moly-lube grease	Medium Thin coating(.008 inches)	GEP - B
or equivalent	Small Apply and wipe off	GEP - C

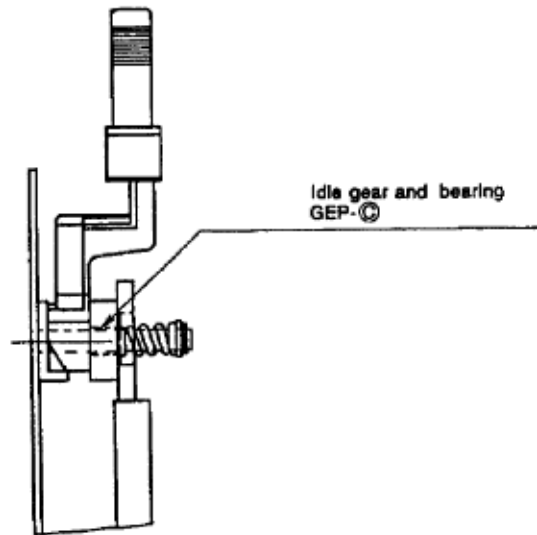
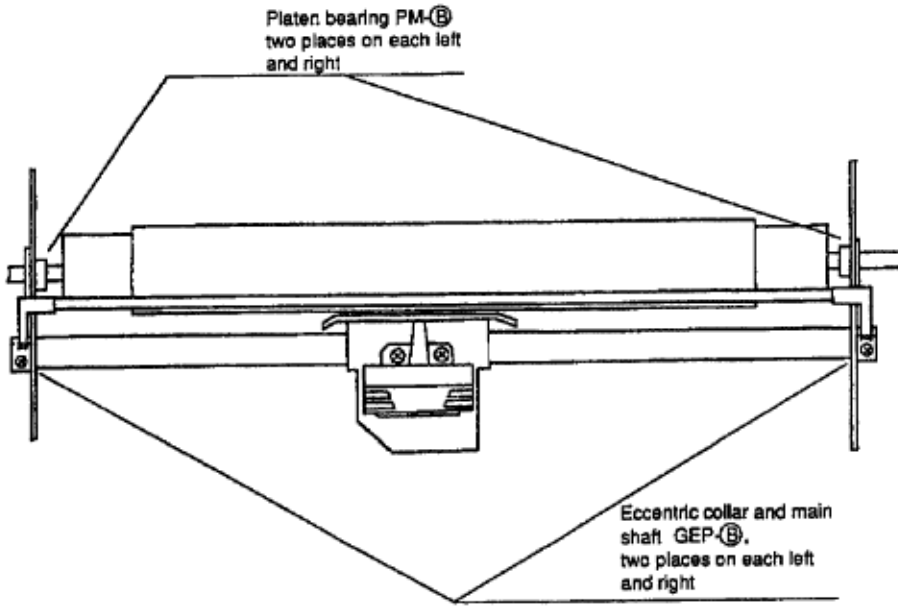



Service Guide ML393/ML393CPlus

Chapter 3 Maintenance

Ribbon Feed Assembly

Type	Amount	Diagram Designation
Oil	Abundant	PM- A
Machine Oil	Medium: 3 - 4 Drops	PM - B
10w-30 or equivalent	Small: 1 Drop	PM - C
Grease	Abundant	GEP - A
Alvania grease #2 EP Moly-lube grease	Medium Thin coating(.008 inches)	GEP - B
or equivalent	Small Apply and wipe off	GEP - C

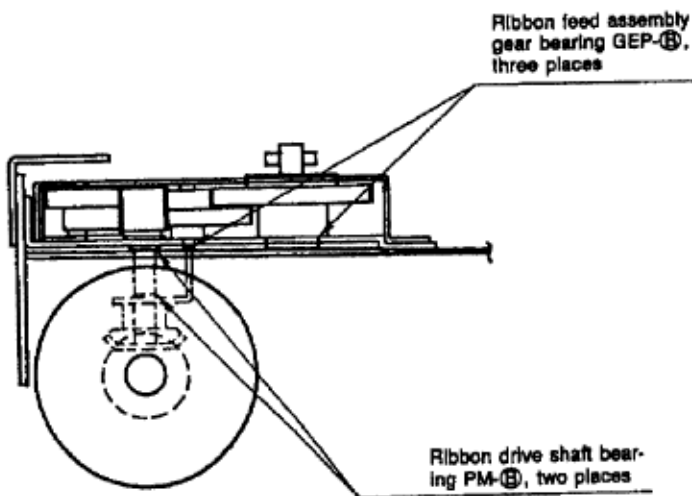
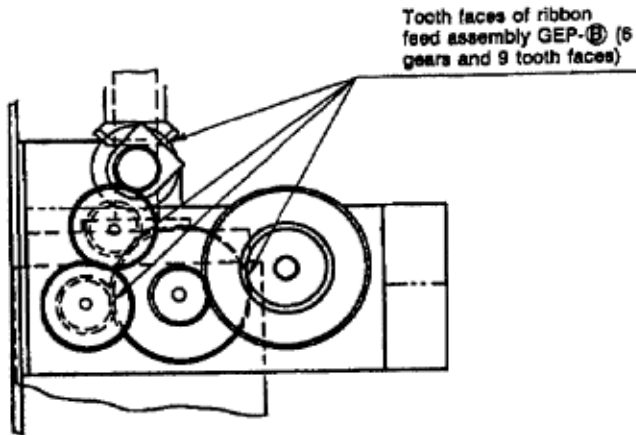

Copyright 1997, Okidata, Division of OKI America, Inc. All rights reserved. See the OKIDATA Business Partner Exchange (BPX) for any updates to this material. (<http://bpx.okidata.com>)



Service Guide ML393/ML393CPlus

Chapter 3 Maintenance

Lubrication Points (Color)

Type	Amount	Diagram Designation
Oil	Abundant	PM- A
Machine Oil	Medium: 3 - 4 Drops	PM - B
10w-30 or equivalent	Small: 1 Drop	PM - C
Grease	Abundant	GEP - A
Alvania grease #2 EP Moly-lube grease	Medium Thin coating(.008 inches)	GEP - B
or equivalent	Small Apply and wipe off	GEP - C

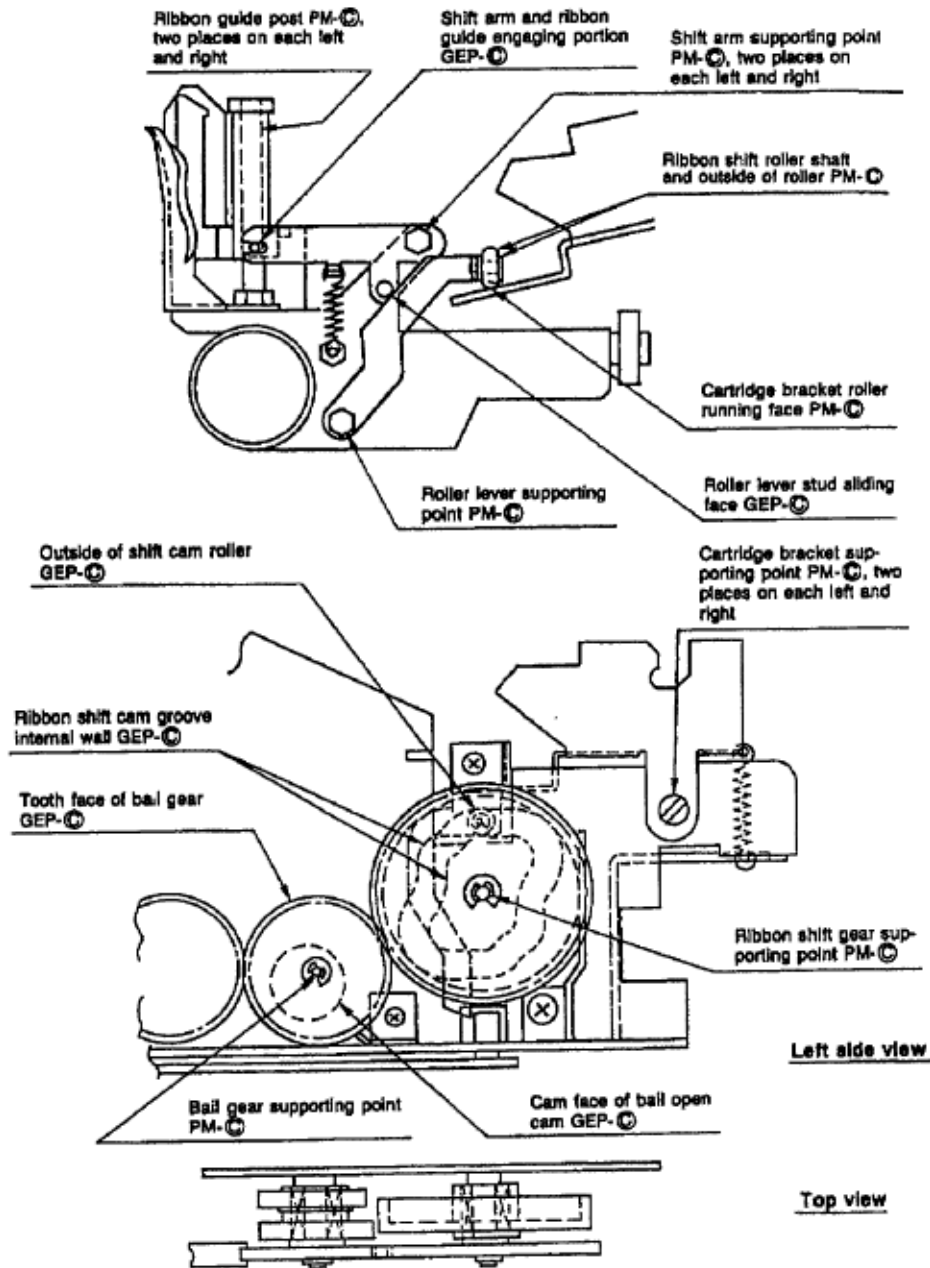

Copyright 1997, Okidata, Division of OKI America, Inc. All rights reserved. See the OKIDATA Business Partner Exchange (BPX) for any updates to this material. (<http://bpx.okidata.com>)



Service Guide ML393/ML393CPlus

Chapter 3 Maintenance

Lubrication Points (Options)

Type	Amount	Diagram Designation
Oil	Abundant	PM- A
Machine Oil	Medium: 3 - 4 Drops	PM - B
10w-30 or equivalent	Small: 1 Drop	PM - C
Grease	Abundant	GEP - A
Alvania grease #2 EP Moly-lube grease	Medium Thin coating(.008 inches)	GEP - B
or equivalent	Small Apply and wipe off	GEP - C

Lubrication points of bottom push tractor unit (option)

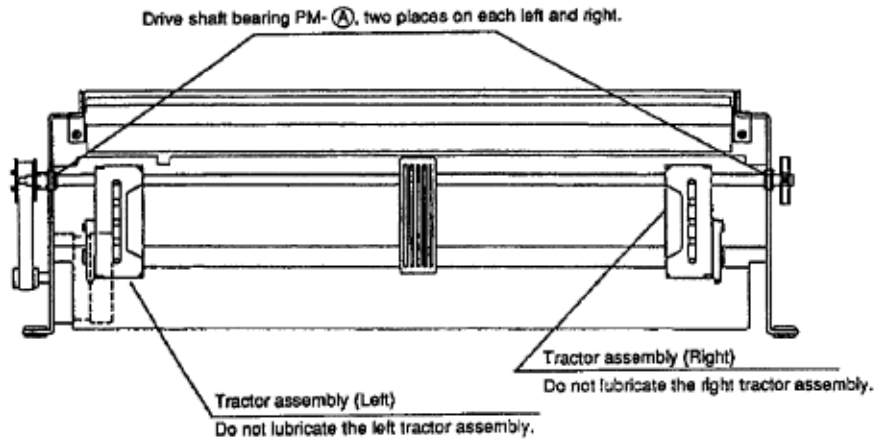

Lubrication points of pull tractor unit (option)

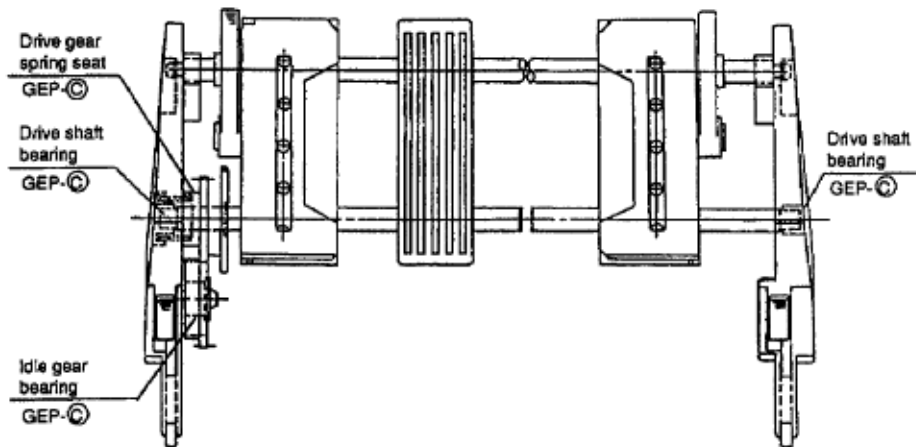



Service Guide ML393/ML393CPlus

Chapter 3 Maintenance

3.6 SHIPPING INSTRUCTIONS

3.6.01 Return for Service

CAUTION:

When shipping the printer, use the original packaging to prevent damage.

Be sure to secure the printhead so it will not move during shipment.

1. Locate the original packaging or order replacement packaging from Okidata. [\(Refer to Appendix B !\[\]\(661ad2fdbe8fa1392f2b194cfa45d124_img.jpg\)\)](#)
2. Make sure the printhead is secured so it will not move during shipment.
3. Remove the platen knob. Be sure to place it in the shipping container.
4. Pack the unit, using the materials from Step 1.

3.6.02 All Other Returns

CAUTION:

The product MUST be returned in the original packaging.

The product MUST be returned with ALL originally supplied factory items.

Be sure to secure the printhead so it will not move during shipment.

1. Locate the original packaging or order replacement packaging from Okidata. [\(Refer to Appendix B !\[\]\(09885fa7dbc7efea01a3982f2e00fbcd_img.jpg\)\)](#)
 2. Locate the originally supplied factory items. (Refer to the Set-up Guide.)
 3. Make sure the printhead is secured so it will not move during shipment.
 4. Pack the unit, using the materials from Step 1.
-



Service Guide ML393/ML393CPlus

Chapter 4 Failure Analysis

4.1 OVERVIEW

4.1.01 Introduction

This section is used to isolate problems to the assembly level. Application problems and detection of faulty components on the printed circuit boards are NOT addressed.

When troubleshooting a defective unit, follow these steps.

1. [Refer to Section 4.3 !\[\]\(00454fbbe8db418db0de5eebfa916a08_img.jpg\), which explains where to check for updates to the troubleshooting information.](#)
2. [Section 4.4 !\[\]\(fd0f3d0c9a8d9b3ff3951bcf7c4bf0c0_img.jpg\) contains tips on preventing problems, as well as a list of common problems.](#)
3. [Section 4.5 !\[\]\(e0cf2596b7f15139c12c58233ba748a6_img.jpg\) shows samples of abnormal outputs.](#)
4. [Section 4.6 !\[\]\(7229103dad454bef452b933d3e01b45a_img.jpg\) provides tables of error messages.](#)
5. [Section 4.7 !\[\]\(32dc4fd1d8720a74b95d374e8ccedb9f_img.jpg\) contains the Repair Analysis Procedures \(RAPs\).](#) Each RAP will ask you questions or require you to make observations. The answers to these questions and the results of your observations determine your next course of action. Use the RAP Index to identify which RAP should be used to resolve the problem with the machine.
6. [Section 4.8 !\[\]\(48a23a052e2d439163363b6592817d27_img.jpg\) provides the procedures for various printer tests.](#)
7. [Section 4.9 !\[\]\(93c6912adf4f8e7e05aabb5d1aff902e_img.jpg\) lists the resistance check points.](#)
8. [Section 4.2 !\[\]\(b9953ed32faeff89b19f343a71b817c3_img.jpg\) lists methods for reporting problems.](#) If you encounter a situation that is NOT addressed by the documentation in this kit, please report the problem to Okidata, using one of the methods listed.

Refer to the Service Center Reference Guide for information on contacting Okidata.

4.1.02 Printer Serial Number Identification

To identify the revision level of a printer, record the serial number from the back of the printer. Refer to the following to decode the serial number.

Example Printer Serial Number: 401A0154693

Date Code 401 (4 = year. 01 = month)

Revision A

Serial Number 0154693

4.1.03 Firmware Revision Level Identification

To identify the revision level and part number of the firmware, print the Rolling ASCII Test or the Font Test.

[Refer to Section 4.8 !\[\]\(683dba75afe26e28cd4de5730b776760_img.jpg\) for information on printing the tests.](#)

Header

At the top of each test is a header.

This header provides the information listed below.

ML393+ E I A P F/W 01.07 YR4077-1289

RES 01.00

1. Printer Model ML393+
2. Emulation EI
3. Version A P
4. Firmware Revision Number 01.07
5. Firmware Part Number YR4077-1289
6. Character Generator Revision Number 01.00
7. Character Generator Part Number Not Shown 1 2 3 4 5 6

Copyright 1997, Okidata, Division of OKI America, Inc. All rights reserved. See the OKIDATA Business Partner Exchange (BPX) for any updates to this material. (<http://bpx.okidata.com>)



Service Guide ML393/ML393CPlus

Chapter 4 Failure Analysis

4.2 REPORTING PROBLEMS

4.2.01 General Information

Okidata strives to provide accurate and detailed service information through its training materials. The Technical Training Group realizes that service technicians have valuable experience, knowledge, and opinions. Okidata strongly encourages you to report any problems you may encounter when using the materials of this training kit. Please be as specific and detailed as possible. Your comments, suggestions, and criticisms are used to update and revise training kits.

You should reference the training materials when servicing Okidata products. Most problems can be solved by using the information provided in the training materials. If you encounter a situation that cannot be solved, please let Okidata know.

Refer to the Service Center Reference Guide for information on contacting Okidata.

4.2.02 Problem Lists

Technicians frequently request a list of common problems specific to a product. Technical Training Kits are written before a product is shipped to customers. Therefore, such information is NOT available when a product is first released.

However, Okidata wants to respond to these requests. Okilink II provides round-table discussions on technical problems. Errors and corrections in the training materials are listed in the Training Section of Okilink II. The Technical Service Bulletins (also known as Okidata's Monthly Mail) are available via Okilink II. Situations that are NOT addressed in the reference documentation, technical service bulletins, or round-tables may be reported to the Dealer Service and Support Engineers (Contact Technical Support) or the Technical Training Group. You will receive a response to your message within one business day.

The information on Okilink II is the most accurate and up-to-date technical information available from Okidata. This is only possible with your assistance. By reporting your suggestions, concerns, and problems, Okidata can provide the best possible information.

Your cooperation is greatly appreciated. Thank you for your help!

4.2.03 Reporting Methods

Okilink II

You may use Okilink II to report your findings. Refer to the Service Center Reference Guide for information on using Okilink II.

Course Critique

Use the Course Critique to report any problems you find as you are completing the self-paced training.

Fax Number

If you wish to fax your response, please use the numbers listed in the Service Center Reference Guide.

Mailing Address

If you respond by mail, please use the appropriate address listed in the Service Center Reference Guide.

Information Provided

Please provide the following information when reporting problems.

Okidata Dealer Number

Technician's Name

Company Name

Company's Address (Street, City, State/Province, ZIP / Postal Code, Country)

Telephone and Fax Numbers (with area / country access codes)

Product Name

Units Serial Number

Firmware Revision Level

Description of Problem

Document Name (with page number or procedure) with error or problem.

Copyright 1997, Okidata, Division of OKI America, Inc. All rights reserved. See the OKIDATA Business Partner Exchange (BPX) for any updates to this material. (<http://bpx.okidata.com>)



Service Guide ML393/ML393CPlus

Chapter 4 Failure Analysis

4.3 TROUBLESHOOTING UPDATES

4.3.01 General Information

Okidata distributes updated troubleshooting information in three ways.

Okilink II

Faxable Facts

Technical Service Bulletins

4.3.02 Okilink II

Okilink II is Okidata's Bulletin Board Service. This service is available to all Okidata Certified Service Technicians. Okilink II provides troubleshooting and service information. Technicians can download files, ask questions of Okidata's technical support personnel, and participate in round table discussions about Okidata products and services. Technical Service Bulletins, Recommended Spare Parts Lists, Printer Drivers, Product Specifications, and Service Training Information are also available.

Refer to the Service Center Reference Guide for information on accessing Okilink II.

4.3.03 Faxable Facts

Okidata's Faxable Facts is an automated fax document retrieval system. It is maintained by Okidata's Customer Information Center. Answers to common questions about Okidata products are available through Faxable Facts.

Refer to the Service Center Reference Guide for information on accessing Faxable Facts.

4.3.04 Technical Service Bulletins

Okidata's Technical Service Bulletins (TSBs) contain technical information developed after product release. Firmware updates, part number changes, and procedural changes are some of the subjects covered by these bulletins. The TSBs are distributed through Okilink II.

Refer to the Service Center Reference Guide for information on accessing Okilink II.



Service Guide ML393/ML393CPlus

Chapter 4 Failure Analysis

4.4 TROUBLESHOOTING TIPS

4.4.01 Preliminary Checks

1. Is the product being operated under the proper ambient conditions?
2. Does the paper being used meet the specifications for this product?
3. Has the ribbon been replaced as recommended?
4. Has the ribbon been installed properly?
5. Is an Okidata ribbon being used?
6. Is the printhead gap correctly set?
7. When replacing the main control board, be sure to remove any socketed PROMS and EEPROMS.

Replacement printed circuit boards are shipped WITHOUT these items.

When removing PROMs and EEPROMs, you MUST follow standard Electrostatic Sensitive Device (ESD) safety precautions or you may damage the components.

8. Is the firmware the latest (current) revision?
 9. Are the correct printer drivers being used for the printer?
 10. Is the printer driver being used the latest (current) release?
-



Service Guide ML393/ML393CPlus

Chapter 4 Failure Analysis

4.4.02 Problem Categories

There are three categories of problems that you might encounter when servicing the printer.

ALARM Lamp Blinks (Fatal Errors)

The following can cause the ALARM lamp to blink.

Open Bail Arm

Jammed Paper

Printhead Cannot Move

Other Fatal Error

When the ALARM Lamp is blinking, check the items listed below.

1. Close the bail arm.
2. Check for a paper jam.
3. Verify that the printhead moves freely.
4. Record the status of the PRINT QUALITY and CHARACTER PITCH lamps.
5. **Refer to the Alarm Lamp Codes Table. (Section 4.6 )**
6. Locate the error.
7. Perform the designated corrective action.

Operational Errors

An Operational Error is usually not accompanied by an ALARM Lamp.

Refer to the Start Here Flowchart (Section 4.4.03 ) and perform the corrective action.

ALARM Lamp Lights (Paper End/Jam Conditions)

A solid ALARM Lamp usually indicates a cover open, a paper jam, or paper-end (out of paper) condition.



Service Guide ML393/ML393CPlus

Chapter 4 Failure Analysis

4.4.03 START HERE Flowchart

START

Does the failure occur immediately after the unit is powered ON?

YES Which of the following resembles the problem?

Power is not supplied to the printer

[Refer to RAP 01](#) 

No spacing operation

[Refer to RAP 02](#) 

ALARM lamp is blinking

[Refer to Section 4.6](#) 

NO The problem occurs during printing.

[Refer to the RAP Index - Section 4.7](#) 

Copyright 1997, Okidata, Division of OKI America, Inc. All rights reserved. See the OKIDATA Business Partner Exchange (BPX) for any updates to this material. (<http://bpx.okidata.com>)



Service Guide ML393/ML393CPlus

Chapter 4 Failure Analysis

4.4.04 Tips for Preventing Image Problems

1. Make sure that the ribbon is not "dried out". If the printer output is faded, install a new ribbon, then print another sample.
2. Make sure that the paper you are using is within specifications. [Paper specifications can be found in Section 1 of this Service Handbook](#) .
3. Always place the Head Gap Lever in the position appropriate for the paper that you are using.

Setting	Paper Type
1	12 - 15 lb. paper
2	20 - 24 lb. paper
3 - 4	Labels
3 - 4	Two-part forms
4 - 5	Three-part forms
7	Four-part forms
5 - 9	Envelopes



Service Guide ML393/ML393CPlus

Chapter 4 Failure Analysis

4.4.05 Common Problems

1. Nothing happens when the printer is powered ON.

Make sure the printer is plugged in.

Check the power cord connection to the printer and the outlet.

If a power strip is being used, make sure the strip is powered ON.

2. The ALARM lamp is lit.

The printer may be out of paper or the paper may have jammed. The SEL lamp will not light. After loading paper, press the SEL switch.

The front cover may be open. Close the front cover.

The paper lever may not be set for the type of paper being used. Position the lever correctly.

If the ALARM lamp does not go out after paper is loaded, refer to Section 4.5 of this Service Handbook.

3. The printer does not print when the computer sends it data.

The printer may be deselected. Make sure that the SEL lamp is lit. If it is not, press the SEL switch.

Verify that the interface cable is correctly installed.

4. The paper keeps jamming.

Verify that the top of form is set so that the paper is held in place by the bail bar. If the top edge of the page is below the bail, it will catch on the bail as it advances. Do not use the FORM FEED switch to load paper into the printer.

If the paper does jam, power OFF the printer. Carefully back the paper out of the paper path by using the platen knob. Remove any shreds of paper from the paper path.

5. The printer suddenly changes to unidirectional printing. It then stops printing completely. The MENU light is flashing.

This indicates a Printhead Overheat Condition. When the printer prints for a long period of time, heat will build up in the printhead. When the printhead temperature reaches approximately 115 degrees Celsius, the printer will print unidirectionally. If the temperature continues to rise, printing will stop until the printhead cools. Printing will resume after the printhead cools.

6. The ALARM lamp is blinking.

The bail is open. Close it.

The paper or ribbon is jammed. Clear the paper path. Thread the ribbon correctly.

The printhead cannot move. Clear the obstruction.

7. Static electricity causes the paper to stick.

In cold, dry weather, static charges can build up on continuous-form paper. This can make the paper cling to the paper separator. If this problem occurs during high-volume printing jobs, try moving the single sheet paper guides on the separator together so that the paper rests on the guides rather than on the separator itself.

8. Files do not print the way the printer menu and front panel are set.

Before sending a file to a printer, many word processors send an initialization string. This string contains codes that reset the printer to a default set of features. Otherwise, the printer might print using features set for a previous job. The codes will override panel or menu settings.

Check the word processors manual to see if the initialization string can be modified. If so, remove any codes that interfere with the printers settings.

To set the printer to ignore the reset code, follow this procedure.

1. Verify that the printer is loaded with paper.
2. Press SELECT until the SELECT lamp goes out.
3. Press QUIET to enter Menu Mode.
4. The first Group/Item/Setting will print.
5. Press GROUP until GENERAL CONTROL prints.
6. Press ITEM until RESET INHIBIT prints.
7. Press SET until VALID prints.
8. Press EXIT save the settings and to exit the Menu Mode.

This will stop the reset code from resetting the printer, but other codes in the initialization string may still override the printer Menu and / or front panel settings.

9. FONT, PRINT QUALITY, and CHARACTER PITCH (on the operator panel) do not work.

The Operator Panel Function Item in the Printer Menu can be set to enable (FULL OPERATION) or disable (LIMITED OPERATION) these features. If the printer is part of a customized system or if it is used by different operators, a system manager may be using this feature to maintain proper print settings.

To activate these switches, power OFF the printer. Press and hold QUIET while powering ON the printer. Follow the normal menu procedures to set the Operator Panel Functions Item to FULL OPERATION.

10. Output is missing dots.

Check the headgap setting. Move the head gap lever to a lower setting.

Setting	Paper Type
1	12 - 15 lb. paper
2	20 - 24 lb. paper
3 - 4	Labels
3 - 4	Two-part forms
4 - 5	Three-part forms

7	Four-part forms
5 - 9	Envelopes

Perform the Printhead Gap Adjustment. Refer to Section 3.3 of this Service Handbook for details.

Refer to RAP 03.

11. Strange symbols and incorrect fonts appear during a print run.

The printer driver does not agree with the emulation selected for the printer.

OR

Incorrect printer commands are embedded within the software.

To check the selected emulation, follow this procedure.

1. Verify that the printer is loaded with paper.
2. Press SELECT until the SELECT lamp goes out.
3. Press QUIET to enter Menu Mode.
4. The first Group/Item/Setting prints.
5. Press GROUP until GENERAL CONTROL prints.
6. Press ITEM until EMULATION MODE prints.
7. Press SET until the desired emulation prints.
8. Press EXIT to save the settings and exit the Menu Mode.

If the emulation is correct, check the software documentation on how to select a printer driver. Verify that the selected driver is correct for the emulation. Refer to the Reference Guide. Drivers near the top of the list are more compatible with the printer than drivers near the bottom of the list. If the software does NOT offer any driver on the list, check with the software manufacturer to see if additional drivers have been added since the software was purchased.

Verify that any embedded commands in the software were correctly entered.



Service Guide ML393/ML393CPlus

Chapter 4 Failure Analysis

Epson / IBM, Self Test Revision 1.16 (FCO 7681)

NOTE:

This information is also provided in Technical Service Bulletin 3201.

Technical Service Bulletin 3201 covers Field Change Order 7681.

The Microline 393 / 393C Epson IBM printers may experience a premature power supply failure as a result of the graphics speed running above the specified duty cycle.

The affected printers have a self test revision of 1.16 and are Epson / IBM Models.

The ROM being replaced is Q1 of the Epson / IBM personality module.

Any printer with a self test revision of 1.22 has already been updated.

Field Change Order (FCO) 7681 includes the new ROM and installation instructions.

This FCO may be ordered through Okidata's Order Processing Center.

The part number for the FCO is 58218201.

NOTE:

FCO 7693 replaces FCO 7681.



Service Guide ML393/ML393CPlus

Chapter 4 Failure Analysis

Missing Spaces When Printing Wide Reports (FCO 7693)

NOTE:

This information is also provided in Technical Service Bulletin 3203.

Technical Service Bulletin 3203 covers Field Change Order 7693.

When printing "wide" reports in letter quality mode, columns may be misaligned. The alignment problem is caused by missing (dropped) spaces.

Field Change Order (FCO) 7693 corrects this problem. It also corrects premature power supply failures resulting from a graphics speed running above the specified duty cycle. (FCO 7681)

FCO 7693 includes a program ROM, insulating seals, and installation instructions.

After installing this FCO, the printer will print a self test of 1.21.

This FCO may be ordered through Okidata's Order Processing Center.

The part number for FCO 7693 is 58218401.

NOTE:

FCO 7693 replaces FCO 7681.

Copyright 1997, Okidata, Division of OKI America, Inc. All rights reserved. See the OKIDATA Business Partner Exchange (BPX) for any updates to this material. (<http://bpx.okidata.com>)



Service Guide ML393/ML393CPlus

Chapter 4 Failure Analysis

Self Test Revisions 1.07 and 1.10 (FCO 7730)

NOTE:

This information is also provided in Technical Service Bulletin 3209.

Technical Service Bulletin 3209 covers Field Change Order 7730.

Microline 393 / 393C-Plus Epson / IBM self test revisions 1.07 and 1.10 print a copy right notice (Copyright 1989 Oki Electric Ind. LTD and Bitstream Inc.) while printing data. Self test revision 2.04 exhibits error code 47.

Field Change Order (FCO) 7730 includes a ROM, installation instructions, and a product update sheet. The update sheet lists the functional enhancements incorporated into self test revision 2.04.

The ROM at location Q6 of the main control board is replaced. The self test revision will be 2.05.

This FCO may be ordered through Okidata's Order Processing Center.

The part number for FCO 7730 is 58219601.

NOTE:

The serial numbers for the production cut-in of self test revision 2.05 are listed below.

Configuration	Serial Number
120 V Black	007A0019018
220 V Color	007A0002028
120 V Black	007A0000115
220 V Color	007A0000061



Service Guide ML393/ML393CPlus

Chapter 4 Failure Analysis

Parallel Timing Specification Changes

NOTE:

This information is also provided in Technical Service Bulletin 3210.

Firmware Revision 2.04 and above provides better compatibility between the Microline 393-Plus and Microline 393C-Plus printers and high speed computers and / or non-DOS operating systems.

The firmware changes the parallel interface timing specification. The BUSY and ACKNOWLEDGE signals are offset and reduced to eliminate potential noise and timing problems with these interface signals.

Firmware Revision 2.04 and above changes the printer menu. The feature, CPU Compensation, is added. Two settings are available for this feature: Standard and Special.

- Standard

This is the default setting.

It allows the printer to work with high speed computers and / or non-DOS operating systems.

Use this setting from most applications.

- Special

Uses the "old" timing interface specifications.

The symptoms listed below are typical of a problem with the parallel interface timing.

- "Paper End" message on the computer screen
- Hesitation problems
- No printed data



Service Guide ML393/ML393CPlus

Chapter 4 Failure Analysis

Jumper SP2 Added to Main Control Board

NOTE:

This information is also provided in Technical Service Bulletin 3211.

The Slave ROM Q17 has been changed to a Masked CPU Q11.

All ICs are located on the main control board.

Jumper Plug SP3 should be open for the Microline 393-Plus.

Jumper Plug SP3 should be shorted for the Microline 393C-Plus.

Jumper SP2 has been added and is set on the A side for the masked ROM change.

NOTE:

The serial numbers for the production cut-in of the change are listed below.

Configuration	Serial Number
Microline 393 E/I (Black) 120 V	0011A0030666 and above
Microline 393 E/I (Black) 220 V Color	0011A0000275 and above
Microline 393 E/I (Color) 120 V Black	0011A0003052 and above
Microline 393 E/I (Color) 220 V Color	N/A



Service Guide ML393/ML393CPlus

Chapter 4 Failure Analysis

Font Name Changes in Menu Mode

NOTE:

This information is also provided in Technical Service Bulletin 3212.

The changes listed below have been made to the Menu Mode font names.

TMS Roman became Dutch.

Helvetica became Swiss.

The Slave ROM Q17 became a Masked CPU Q11.

All ICs are located on the main control board.

Jumper Plug SP3 should be open for the Microline 393-Plus.

Jumper Plug SP3 should be shorted for the Microline 393C-Plus.

Jumper SP2 has been added and is set on the A side for the masked ROM change.

NOTE:

The serial numbers for the production cut-in of the change are listed below.

Configuration	Serial Number
Microline 393 E/I (Black) 120 V	102A0037642 and above
Microline 393 E/I (Black) 220 V Color	102A0000371 and above
Microline 393 E/I (Color) 120 V Black	102A0003724 and above
Microline 393 E/I (Color) 220 V Color	N/A



Service Guide ML393/ML393CPlus

Chapter 4 Failure Analysis

Modifications to Q6, Main Control Board

NOTE:

This information is also provided in Technical Service Bulletin 3213.

The main control board has been modified. EPROM socket location Q6 accepts four additional pins.

Either a 28 pin EPROM or a 32 pin Masked ROM may be installed with no changes and full compatibility.

No jumper changes are necessary.

When installing a 28 pin EPROM, the four unused pins (two on each side) are on the left side of the socket. Refer to the diagram.

The 32 pin Masked ROM uses all 32 pins on the socket.

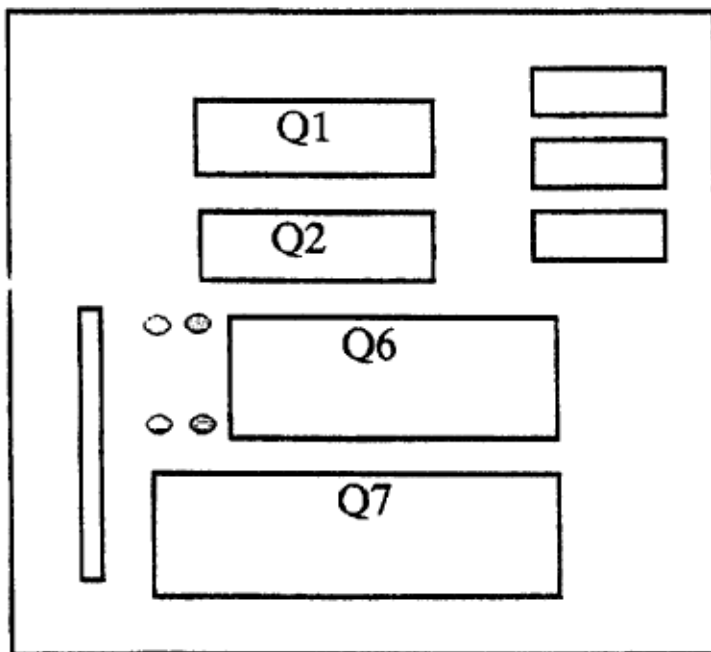

LQEM Bd. w/ 28 Pin EPROM at Q6

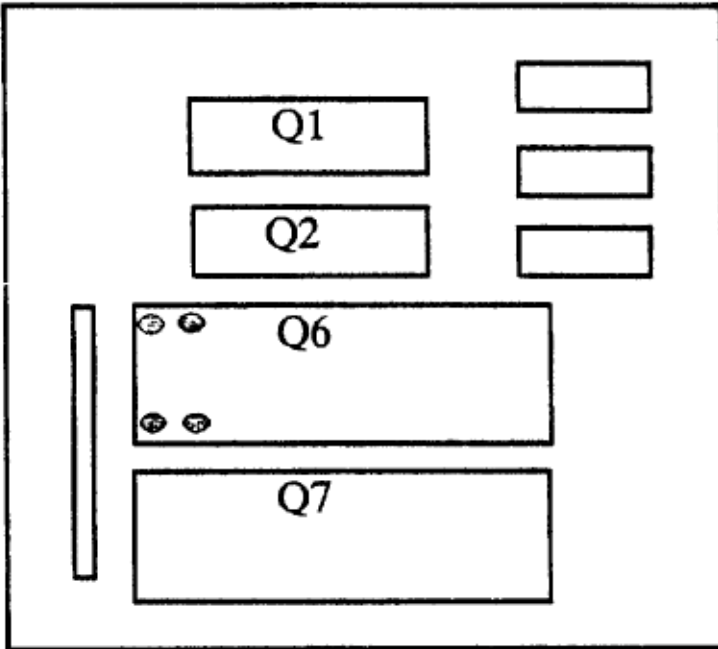

LQEM Bd. w/ 32 Pin Masked ROM at Q6

Copyright 1997, Okidata, Division of OKI America, Inc. All rights reserved. See the OKIDATA Business Partner Exchange (BPX) for any updates to this material. (<http://bpx.okidata.com>)

4.5 ABNORMAL OUTPUT

4.5.01 Output Samples

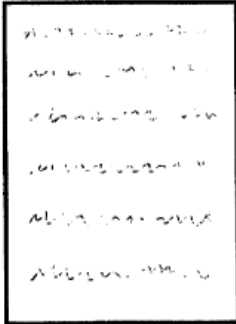

Light Print on the Entire Page

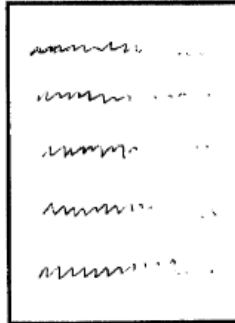

Uneven Print Density

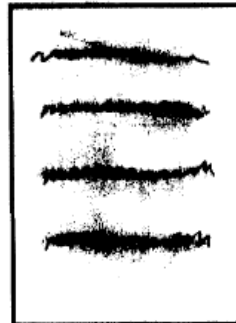

Smeared Print

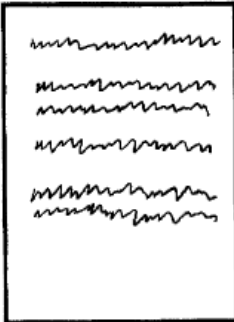

Inconsistent Line Feed

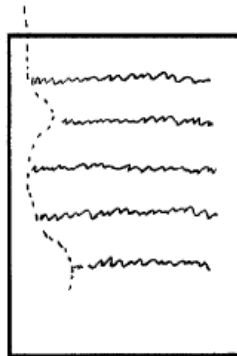

Drifting Margin

Light Print on the Entire Page

Possible Causes

- Ribbon is "dried out". Replace the ribbon.
- Head gap lever is in the incorrect position. Place the lever in correct position.
- Paper is not within specification. Refer to Section One for paper specification.

Uneven Print Density

Possible Causes

- Printhead gap not within specification. Perform the printhead gap adjustment.
- Defective platen. Replace the platen.

Smeared Print

Possible Causes

- Head gap lever is in the incorrect position. Place the lever in correct position.
- Paper is not within specification. Refer to Section One for paper specification.
- Ribbon protector is missing or broken. Replace the ribbon protector.

Inconsistent Line Feed

Possible Causes

- Power OFF the printer. Turn the platen knob. The platen should rotate smoothly. If it does not, remove the cause of the binding.
- Make sure that the line feed belt tension is within specification. If it is not, tighten the line feed belt.
- Defective line feed motor. Replace the line feed motor.

Drifting Margin

Possible Causes

- Power OFF the printer. Move the carriage assembly. The carriage should move smoothly. If it does not, remove the cause of the binding.
 - Make sure that the space belt tension is within specification. If it is not, tighten the belt.
-

Copyright 1997, Okidata, Division of OKI America, Inc. All rights reserved. See the OKIDATA Business Partner Exchange (BPX) for any updates to this material. (<http://bpx.okidata.com>)



Service Guide ML393/ML393CPlus

Chapter 4 Failure Analysis

4.6 FAULT ALARMS

4.6.01 General Information

When an error condition exists, the ALARM LAMP will flash. The operator panel is used to display printer error conditions. The type of error condition can be determined by decoding the operator panel lamps.

Refer to the Alarm Codes Table in this section to identify both the error condition and the recommended corrective action for each condition.

NOTE:

The Alarm Codes Table only applies in situations when the ALARM LAMP is flashing.

Alarm Codes Table

Print Quality			Character Pitch				Alarm Description	Alarm Code	Corrective Action
LQ	NLQ	UTL	15	17	20	PROP			
		ON				ON	MPU Internal RAM Error	11	Replace control board
		ON			ON		Program ROM Error	12	Replace Master ROM
		ON			ON	ON	Resident CG Error	13	Replace control board
	ON					ON	Slave ROM/RAM Error	21	Replace Slave ROM
	ON				ON		Slave/Master Matching Error	22	Replace Master/Slave ROM

	ON	ON				ON	External RAM Error	31	Replace RAM cartridge
ON						ON	Command FIFO Check Error	41	Replace control board
ON					ON	ON	Print Pass Error	43	Replace control board
ON				ON			Position Sense Error	44	Replace control board
ON		ON				ON	Print Over Run Error	51	Replace control board
ON		ON			ON		Print Stop Error	52	Replace control board
ON		ON			ON	ON	Head Homing Error	53	Refer to RAP 03
ON		ON		ON	ON		EEPROM Write Error	56	Replace control board
ON		ON		ON	ON	ON	Spacing Error	57	Refer to RAP 02
ON		ON	ON		ON	ON	Ribbon Error	5B	Refer to RAP 04
ON		ON	ON	ON			Bail Arm Error	5C	Refer to RAP 05
ON	ON						Fan Alarm	60	Replace Power Supply Unit

							Power Lamp Not Lit	N/A	Refer to RAP 01
							Missing Dots	N/A	Refer to RAP 06
							Ribbon Feed Problem	N/A	Refer to RAP 07
	OPERATIONAL ERRORS						Line Feed Problem	N/A	Refer to RAP 08
							Operator Panel Problem	N/A	Refer to RAP 09
							Data Receiving Problem	N/A	Refer to RAP 10
							Ribbon Shift Problem	N/A	Refer to RAP 11

Copyright 1997, Okidata, Division of OKI America, Inc. All rights reserved. See the OKIDATA Business Partner Exchange (BPX) for any updates to this material. (<http://bpx.okidata.com>)



Service Guide ML393/ML393CPlus

Chapter 4 Failure Analysis













4.7 REPAIR ANALYSIS PROCEDURES (RAPs)



4.7.01 Using the RAPs

When using the Repair Analysis Procedures, follow these steps.

1. Go to the RAP Index.
2. Find the RAP which is associated with the printers problem.
3. Go to the appropriate RAP.
4. All RAPs begin with a START statement, followed by questions or another type of statement.

4.7.02 RAP Index

Description	RAP Number
Power Lamp Does Not Light	01 
Space Error (ALARM 57)	02 
Head Homing Error (ALARM 53)	03 
Ribbon Homing Error (ALARM 5B)	04 
Bail Home Error (ALARM 5C)	05 
Wrong Character Character Omission or Dot Omission	06 
Ribbon Feed Trouble	07 
Line Feed Trouble	08 
Malfunction of Operator Panel Switch	09 
Data Receiving Failure	10A 
Parallel Interface Problem	10B 
Serial Interface Problem	10C 

Data Receive Problem Alarm Light Lit	10D 
Color Ribbon Shift Problems	11 

Copyright 1997, Okidata, Division of OKI America, Inc. All rights reserved. See the OKIDATA Business Partner Exchange (BPX) for any updates to this material. (<http://bpx.okidata.com>)



Service Guide ML393/ML393CPlus

Chapter 4 Failure Analysis

RAP 01: Power Lamp Does Not Light

NOTE:

*If the printer operates normally, but the POWER LAMP does not light, replace the Operator Panel.
Refer to Appendix A for voltage test points and connector locations.*

START

Is the AC cable connected to an AC outlet and the printer?

NO Connect the AC cable.

Has the problem been resolved?

YES End of procedure

NO Go to the next step listed below.

YES Is the F1 fuse on the power supply unit open?

YES Replace the fuse F1. If it opens again, replace the power supply unit.

Has the problem been resolved?

YES End of procedure

NO Go to the next step listed below.

NO Are the +5 vdc and +38 vdc present on the control board? Check for +38 vdc at both ends of capacitor C2. Check for +5 vdc between pin 16 of Q2 and the power bar.

NO Are cables CN3 and CN7 on the control board correctly connected?

NO Connect cables CN3 and CN7 at the control board.

YES Replace the power supply unit. *OR* Replace the connection cable.

YES Replace the control board.

Has the problem been resolved?

NO Contact Okidata Technical Support.

YES End of procedure.



Service Guide ML393/ML393CPlus

Chapter 4 Failure Analysis

RAP 02: Space Error (ALARM 57)

START

Is the carriage assembly binding or jammed?

YES Check around the space motor mechanism for any obstructions. Then, remove the cause of the carriage jam.

NO Go to Step A.

Has the problem been resolved?

YES End of procedure.

NO Is fuse F1 on the control board blown?

YES Replace fuse F1.

NO Go to A.

Has the problem been resolved?

YES End of procedure.

NO Go to A.

A

Is +38 vdc present on the control board? Check on both ends of the capacitor C2.

NO Are cables CN1 and CN5 on the control board correctly connected?

YES Replace the control board.

NO Connect them correctly.

Has the problem been resolved?

YES End of procedure.

NO Replace the space motor.

YES Are cables CN3 and CN7 on the control board correctly connected?

YES Replace the power supply unit or connection cable.

NO Connect them correctly.

Has the problem been resolved?

YES End of procedure.

NO Replace the space motor.



Service Guide ML393/ML393CPlus

Chapter 4 Failure Analysis

RAP 03: Head Homing Error (ALARM 53)

START

Is +38 vdc present on the control board? Check for an open fuse on control board.

YES Is connector CN1 on the control board correctly installed?

YES Replace the control board.

NO Correctly install the connector.

Has the problem been resolved?

YES End of procedure.

NO Contact Okidata Technical Support.

NO Are cables CN3 and CN7 on the control board correctly connected to the power supply unit?

YES Replace the power supply unit.

NO Correctly connect the cables.

Has the problem been resolved?

YES End of procedure.

NO Replace the space motor.

Has the problem been resolved?

YES End of procedure.

NO Contact Okidata Technical Support.



Service Guide ML393/ML393CPlus

Chapter 4 Failure Analysis

RAP 04: Ribbon Homing Error (ALARM 5B)

START

Is the printer the color model?

NO Is shorting plug SP3 of the control board open?

NO Set it open.

YES Go to A.

YES Manually rotate the ribbon shift cam counterclockwise. Does it rotate smoothly?

NO Check the areas listed below.

No paper scrap or foreign matter on the gear

Smooth gear meshing

No friction at each fulcrum of the carriage bracket, roller lever and ribbon shift arm

YES Is cable CN2 on the sensor board connected correctly?

NO Connect it correctly.

YES Is cable CN4 on the control board connected correctly?

NO Connect it correctly.

YES Is there dirt or dust on the ribbon home sensor on the sensor board?

YES Clean the sensor.

NO Go to A.

A

Replace the sensor board.

Has the problem been resolved?

YES End of procedure.

NO Replace the bail/ribbon motor.

Has the problem been resolved?

YES End of procedure.

NO Replace the control board.



Service Guide ML393/ML393CPlus

Chapter 4 Failure Analysis

RAP 05: Bail Home Error (ALARM 5C)

START

Manually rotate the bail open gear counterclockwise.
Does it rotate smoothly?

NO Perform the following.

Remove any paper scrap or foreign material near the bail/ribbon motor gear, idle gear and bail open gear.
Check the meshing of each of the above gears.

YES Is cable CN4 on the control board connected correctly?

NO Connect it correctly.

YES Are cables CN2/CN3 on the sensor board connected correctly?

NO Connect them correctly.

YES Is there dirt or dust on any of the sensors on the sensor board?

YES Clean the sensors.

NO Is the bail arm lever damaged?

YES Replace the bail arm lever.

NO Replace the control board.
Has the problem been resolved?

YES End of procedure.

NO Replace the sensor board.

Has the problem been resolved?

YES End of procedure.

NO Replace the bail/ribbon motor.



Service Guide ML393/ML393CPlus

Chapter 4 Failure Analysis

RAP 06: Wrong Character, Character Omission, or Dot Omission

START

Are cables CN2 and CN6 on the control board connected correctly?

NO Connect them correctly.

YES Is cable CN101 on the interface connector board connected correctly?

NO Connect it correctly.

YES Is the interface cable connected correctly?

NO Connect it correctly

YES Are the +/- 8 vdc output voltages supplied by the control board? Check at both ends of C9 for the positive voltage. Check at both ends of C8 for the negative voltage.

YES Replace the printhead.

Has the problem been resolved?

YES End of procedure.

NO Go to A

NO Are cables CN3 and CN7 on the control board properly connected to the power supply unit?

NO Connect them correctly.

YES Replace the power supply unit.

A

Replace the Program and Slave ROMs on the control board. Has the problem been resolved?

YES End of procedure.

NO Replace the control board.

Has the problem been resolved?

YES End of procedure.

NO Are the cables connected to CN2 and CN6 on the control board damaged?

YES Replace the cables.

NO Check the MENU Settings related to the interface. Baud Rate Character Format Protocol BUSY Signal output selection



Service Guide ML393/ML393CPlus

Chapter 4 Failure Analysis

RAP 07: Ribbon Feed Trouble

START

Remove the ribbon cartridge and rotate the ribbon cartridge ribbon feed knob.

Does it rotate smoothly?

YES Check to see if the ribbon lock mechanism has been disengaged.

NO Replace the ribbon cartridge.

Manually shift the carriage to the left and to the right.

Does the ribbon feed shaft rotate?

NO Replace the ribbon feed assembly.

After the replacement, adjust the backlash between the space motor gear and bevel gear.

YES Check that the ribbon feed shaft is correctly engaged with the ribbon feed roller of the ribbon cartridge.

Copyright 1997, Okidata, Division of OKI America, Inc. All rights reserved. See the OKIDATA Business Partner Exchange (BPX) for any updates to this material. (<http://bpx.okidata.com>)



Service Guide ML393/ML393CPlus

Chapter 4 Failure Analysis

RAP 08: Line Feed Trouble

START

Manually rotate the platen knob.

Does it rotate smoothly?

NO Set the release lever to the open side.

Does the platen knob rotate smoothly?

NO Adjust the mini-pitch belt tension.

YES Perform the following.

1. Check for correct phasing of push tractor (left or right).
2. Replace the push tractor (left or right).
3. Check for smooth meshing of platen gear, idle gear, and drive gear.
4. Remove any foreign matter or dust on the platen gear, idle gear, or drive gear.

YES Is cable CN6 on the control board connected correctly?

NO Connect it correctly.

YES Is cable CN101 on the interface connector board connected correctly?

NO Connect it correctly.

YES Is cable CN102 on the interface connector board connected correctly?

NO Connect it correctly.

YES Replace the control board.

Has the problem been resolved?

YES End of procedure.

NO Replace the line feed motor.

After replacing the line feed motor, adjust the belt tension.



Service Guide ML393/ML393CPlus

Chapter 4 Failure Analysis

RAP 09: Malfunction of Operator Panel Switch

START

Is cable CN1 on the operator panel connected correctly?

NO Connect it correctly.

YES Is cable CN10 on the operator panel connected correctly?

NO Connect it correctly.

YES Replace the operator panel.

Has the problem been resolved?

YES End of procedure.

NO Replace the control board.

Copyright 1997, Okidata, Division of OKI America, Inc. All rights reserved. See the OKIDATA Business Partner Exchange (BPX) for any updates to this material. (<http://bpx.okidata.com>)



Service Guide ML393/ML393CPlus

Chapter 4 Failure Analysis

RAP 10A: Data Receive Failure

START

Is the SELECT lamp blinking?

YES Modify the menu to Ignore DC3.

NO Is the ALARM lamp ON?

YES Refer to RAP 10D.

NO Is the SELECT lamp ON?

NO Place the printer ON-LINE.

YES Is the interface cable connected correctly?

NO Connect it correctly.

YES Is cable CN101 on the interface connector board connected correctly?

NO Connect it correctly.

YES Is cable CN6 on the operator panel connected correctly?

NO Connect it correctly.

YES Are you using a parallel interface?

YES Refer to RAP 10B.

NO Refer to RAP 10C.



Service Guide ML393/ML393CPlus

Chapter 4 Failure Analysis

RAP 10B: Parallel Interface Problem

START

Replace the Master and Slave Program ROMs.

Has the problem been resolved?

YES End of procedure.

NO Replace the control board.

Has the problem been resolved?

YES End of procedure.

NO Perform the following:

1. Replace the interface connector board.
 2. Replace the cable connected to CN6 on the control board.
-

Copyright 1997, Okidata, Division of OKI America, Inc. All rights reserved. See the OKIDATA Business Partner Exchange (BPX) for any updates to this material. (<http://bpx.okidata.com>)



Service Guide ML393/ML393CPlus

Chapter 4 Failure Analysis

RAP 10C: Serial Interface Problem

START

Correctly set the interface menu parameters.

1. Baud rate.
2. Character format.
3. Protocol.
4. Busy signal polarity.

Has the problem been resolved?

YES End of procedure.

NO Are +/-8 vdc outputs provided on the control board?

Check at both ends of C9 for the positive voltage.

Check at both ends of C8 for the negative voltage.

NO Replace the power supply unit.

YES Refer to RAP 10B.

Has the problem been resolved?

YES End of procedure.

NO Replace the power supply board.

Has the problem been resolved?

YES End of procedure.

NO Perform the procedures listed below.

1. Replace the interface connector board.
 2. Replace the cable connected to CN6 on the control board.
-



Service Guide ML393/ML393CPlus

Chapter 4 Failure Analysis

RAP 10D: Data Receive Failure (Alarm Light Lit)

START

Remove the upper cover.

Press and hold the cover open microswitch while powering ON the printer.

Does the alarm lamp come on?

NO Perform the operations listed below.

1. Correctly connect cable CN13 on the control board.
2. Check the alignment between the front access cover and the COVER OPEN switch.
3. Replace the COVER OPEN microswitch/cable assembly.

YES Is the paper properly installed?

NO Install the paper properly.

YES Does the continuous form end microswitch function correctly?

NO Perform the operations listed below.

1. Correctly connect CN103 on the interface connector board.
2. Replace the sheet feeder assembly L.

YES Does the single sheet end sensor function correctly?

NO Perform the operations listed below.

1. Clean the sensor surface.
2. Correctly connect CN1 on the sensor board.
3. Replace the sensor cable assembly.

YES Does the bottom feed paper end sensor function correctly?

NO Perform the operations listed below.

1. Clean the sensor on the sensor board.
2. Correctly connect cable CN4 on the control board.
3. Replace the sensor board.

YES Go to A.

A

Does the release lever microswitch function correctly?

NO Perform the operations listed below.

1. Correctly connect cable CN9 on the main control board.
2. Replace the release lever, microswitch, and cable assembly.

YES Replace the control board.

Has the problem been resolved?

YES End of procedure.

NO Contact Okidata Technical Support.

Copyright 1997, Okidata, Division of OKI America, Inc. All rights reserved. See the OKIDATA Business Partner Exchange (BPX) for any updates to this material. (<http://bpx.okidata.com>)



Service Guide ML393/ML393CPlus

Chapter 4 Failure Analysis

RAP 11: Color Ribbon Shift Problem

START

Does the ribbon shift mechanism operate properly?

NO Go to A.

YES Is BLACK RIBBON set on the menu?

NO Go to B.

YES Set another color.

Has the problem been resolved?

NO Go to B.

YES End of procedure.

A

Is the ribbon installed properly?

NO Correct the ribbon installation.

YES Go to C.

B

Are CN4 on the control board and CN2 on the sensor board connected correctly?

NO Connect the cables correctly.

YES Replace the control board.

Has the problem been resolved?

YES End of procedure.

NO Replace the ribbon/bail motor assembly.

Has the problem been resolved?

YES End of procedure.

NO Go to A.

C

Check the parts listed below.

1. Shoulder screw
2. Ribbon shift arm and spring
3. Roller lever
4. Ribbon cartridge balance spring

Are they normal?

NO Correct the installation or replace the defective assembly.

YES Check the parts listed below.

1. Ribbon shift cam and gear
2. Ribbon shift cam/lever assembly

Has the problem been resolved?

YES End of procedure.

NO Go to D.

D

Check the parts listed below.

1. Ribbon shift cam and gear
2. Ribbon shift cam/lever assembly

Are they normal?

YES Replace the sensor board.

NO Correct the installation or replace the defective assembly.

Has the problem been resolved?

YES End of procedure.

NO Replace the control board.



Service Guide ML393/ML393CPlus

Chapter 4 Failure Analysis

4.8 PRINTER TESTS

4.8.01 General Information

This section covers the tests listed below.

- Rolling ASCII Test
- Font Test
- Serial Interface Loopback Test
- Hexadecimal Dump Mode

The Rolling ASCII and Font Tests check print operations.

The Serial Interface Loopback Test checks the operation of the serial interface board.

The Hexadecimal Dump Mode checks the data transfer between the computer and printer.

Copyright 1997, Okidata, Division of OKI America, Inc. All rights reserved. See the OKIDATA Business Partner Exchange (BPX) for any updates to this material. (<http://bpx.okidata.com>)



Service Guide ML393/ML393CPlus

Chapter 4 Failure Analysis

4.8.02 Rolling ASCII Print Test

General Information

The Rolling ASCII Print Test is a continuous printout of all 96 ASCII characters. The type style set in the printer menu will be utilized.

Use this test to check the items listed below.

Print Quality

Across the entire length of a line

Down the entire page

Line Spacing

Character Formation

Left Margin Alignment

Header Information

At the top of the printout, you will see the Printer Model, Emulation, Country Code, Interface Selection and Firmware Revision Level. This information is often required when performing service or when contacting Okidata. Have this test available during your service call.

Procedure

CAUTION:

If 13.6 inch Paper Width is selected in the Menu, and you run this test with 8.5 inch wide paper loaded, the printer will print on the platen. This may damage the platen, ribbon and printhead.

1. Check the Paper Width setting in the Menu. Load the appropriate width paper or modify the menu setting.
2. Verify that the printer is loaded with paper.
3. Verify that the ribbon is installed.
4. Power OFF the printer.
5. Press and hold the PARK/TOF switch while powering ON the printer. If the printer is powered on and the Rolling ASCII Test does not start, you may have released the PARK/TOF switch too soon.
6. To stop the Rolling ASCII Test, press the SELECT switch or power OFF the printer.

Rolling ASCII Print Test Sample



Service Guide ML393/ML393CPlus

Chapter 4 Failure Analysis

4.8.03 Font Test

General Information

This test will print samples of the available fonts.

The standard fonts are listed below. The cartridge fonts will depend on the cartridge installed.

LQ - ROMAN 10 cpi, Proportional, Super / Subscript

LQ - SWISS 10 cpi, Proportional, Super / Subscript

LQ - COURIER 10 cpi, 12 cpi, 15 cpi, 17.1 cpi, 20 cpi, Proportional, Super / Subscript

LQ - ORATOR 10 cpi, 12 cpi, Super / Subscript

LQ - 12 cpi

UTILITY - 10 cpi, 12 cpi, 15 cpi, 17.1 cpi, 20 cpi,

HSD - 15 cpi

LQ - SWISS Double Width / Height

LQ - SWISS 18 point with Outline

LQ - SWISS 18 point with Shadow

LQ - SWISS Triple Width / Height

Header Information

At the top of the printout, you will see the Printer Model, Emulation, Country Code, Interface Selection and Firmware Revision Level. This information is often required when performing service or when contacting Okidata. Have this test available during your service call.

Procedure

1. Verify that the printer is loaded with paper.
2. Power OFF the printer.
3. Press and hold the LINE FEED switch while powering ON the printer. If the font test does not print after you power ON the printer, you may have released the LINE FEED switch too soon.
4. To stop the test, press the SELECT switch or power OFF the printer.

Font Test Sample

ML 393 + EI A S F/W 02.05 YR4077-1209
RBS 01.10

LQ-ROMAN 10 CPI

```
!"#$%&'()*+,-./0123456789:;<=>?@ABCDEFGHIJKLMNQRSTU VWXYZ[\]^_`abcdefghijklmnopq  
rstuvwxyz{|}~ !"#$%&'()*+,-./0123456789:;<=>?@ABCDEFGHIJKLMNQRSTU VWXYZ[\]^_  
abcdefghijklmnopq rstuvwxyz{|}~
```

LQ-ROMAN PROPORTIONAL

```
!"#$%&'()*+,-./0123456789:;<=>?@ABCDEFGHIJKLMNQRSTU VWXYZ [\]^_`abcdefghijklmnopq  
rstuvwxyz{|}~ !"#$%&'()*+,-./0123456789:;<=>?@ABCDEFGHIJKLMNQRSTU VWX Z[\]^_`abcdefghijklmnopq  
rstuvwxyz{|}~
```

LQ-SWISS 10 CPI

```
!"#$%&'()*+,-./0123456789:;<=>?@ABCDEFGHIJKLMNQRSTU VWXYZ[\]^_`abcdefghijklmnop  
q rstuvwxyz{|}~ !"#$%&'()*+,-./0123456789:;<=>?@ABCDEFGHIJKLMNQRSTU VWXYZ[\]^_  
abcdefghijklmnopq rstuvwxyz{|}~
```

LQ-SWISS PROPORTIONAL

```
!"#$%&'()*+,-./0123456789:;<=>?@ABCDEFGHIJKLMNQRSTU VWXYZ [\]^_`abcdefghijklmnopq  
rstuvwxyz{|}~ !"#$%&'()*+,-./0123456789:;<=>?@ABCDEFGHIJKLMNQRSTU VWX Z[\]^_`abcdefghijklmnopq  
rstuvwxyz{|}~
```

LQ-COURIER 10 CPI

```
!"#$%&'()*+,-./0123456789:;<=>?@ABCDEFGHIJKLMNQRSTU VWXYZ[\]^_`abcdefghijklmnop  
q rstuvwxyz{|}~ !"#$%&'()*+,-./0123456789:;<=>?@ABCDEFGHIJKLMNQRSTU VWXYZ[\]^_  
abcdefghijklmnopq rstuvwxyz{|}~
```

LQ-COURIER 12 CPI

```
!"#$%&'()*+,-./0123456789:;<=>?@ABCDEFGHIJKLMNQRSTU VWXYZ[\]^_`abcdefghijklmnopq  
rstuvwxyz{|}~ !"#$%&'()*+,-./0123456789:;<=>?@ABCDEFGHIJKLMNQRSTU VWXYZ[\]^_  
abcdefghijklmnopq rstuvwxyz{|}~ !"#$%&'()*+,-./0123456789:;<=>?@ABCDEFGHIJKLMNQRSTU VWXYZ[\]^_  
abcdefghijklmnopq rstuvwxyz{|}~
```

LQ-ORATOR 10 CPI

```
!"#$%&'()*+,-./0123456789:;<=>?@ABCDEFGHIJKLMNQRSTU VWXYZ[\]^_`ABCDEFGHIJKLMN  
OPQRSTUVWXYZ[\]^_`ABCDEFGHIJKLMNQRSTU VWXYZ[\]^_  
ABCDEFGHIJKLMNQRSTU VWXYZ[\]^_`
```

LQ-ORATOR 12 CPI

```
!"#$%&'()*+,-./0123456789:;<=>?@ABCDEFGHIJKLMNQRSTU VWXYZ[\]^_`ABCDEFGHIJKLMN  
OPQRSTUVWXYZ[\]^_`ABCDEFGHIJKLMNQRSTU VWXYZ[\]^_  
ABCDEFGHIJKLMNQRSTU VWXYZ[\]^_` ABCDEFGHIJKLMNQRSTU VWXYZ[\]^_`  
"#$%&'()*+,-./0123456789:;<=>?@ABCDEFGHIJKLMNQRSTU VWXYZ[\]^_` ABCDEFGHIJKLMNQRSTU VWXYZ[\]^_`
```

LQ-12 CPI

```
!"#$%&'()*+,-./0123456789:;<=>?@ABCDEFGHIJKLMNQRSTU VWXYZ[\]^_`abcdefghijklmnopq  
rstuvwxyz{|}~ !"#$%&'()*+,-./0123456789:;<=>?@ABCDEFGHIJKLMNQRSTU VWXYZ[\]^_  
abcdefghijklmnopq rstuvwxyz{|}~
```



Service Guide ML393/ML393CPlus

Chapter 4 Failure Analysis

4.8.04 Serial Interface - Loopback Test

NOTE:

In order to run this test, a serial loopback test connector must be attached to the printers serial port.

Procedure

1. Place the printer in the Serial Diagnostic Mode
Set the DIAGNOSTIC TEST menu item to YES.
2. Power OFF the printer.
3. Attach the loopback test connector to the printers serial port.
4. Install continuous feed paper.
5. Power ON the printer.
6. The message LOOP TEST prints.
7. The size of the Message Buffer prints.
8. One of the messages listed below prints.

If the message **OK** prints, the serial interface function has been tested and no problems were found.

If the message **IF BAD** prints, the signal logic was tested and a problem was found.

9. Hexadecimal characters 20 through 7F are transmitted through the transmit data line.
10. The receive data line receives the characters.
11. The message buffer stores the characters.
12. The data prints.
13. The test runs until the SELECT switch is pressed or the printer is powered OFF.
14. To exit test mode, power OFF the printer.
15. Press FORM FEED while powering ON the printer to enter Menu Mode.
16. Set the Diagnostic Test menu item to NO.
17. Power OFF the printer.
18. Remove the loopback test connector.

Serial Loopback Plug Diagram

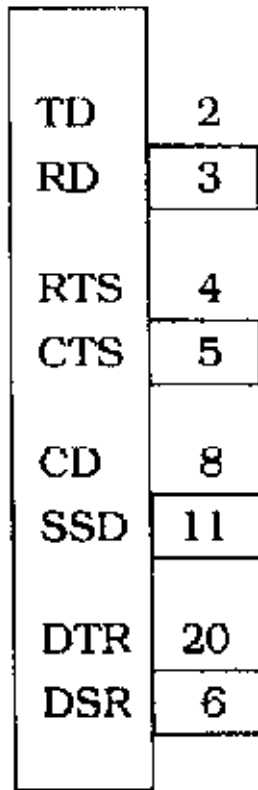

RS232-C (DB 25P Plug)

Loopback Connector Configuration

1. Jumper the following pins together.

Pin 2 to Pin 3

Pin 4 to Pin 5

Pin 8 to Pin 11

Pin 6 to Pin 20

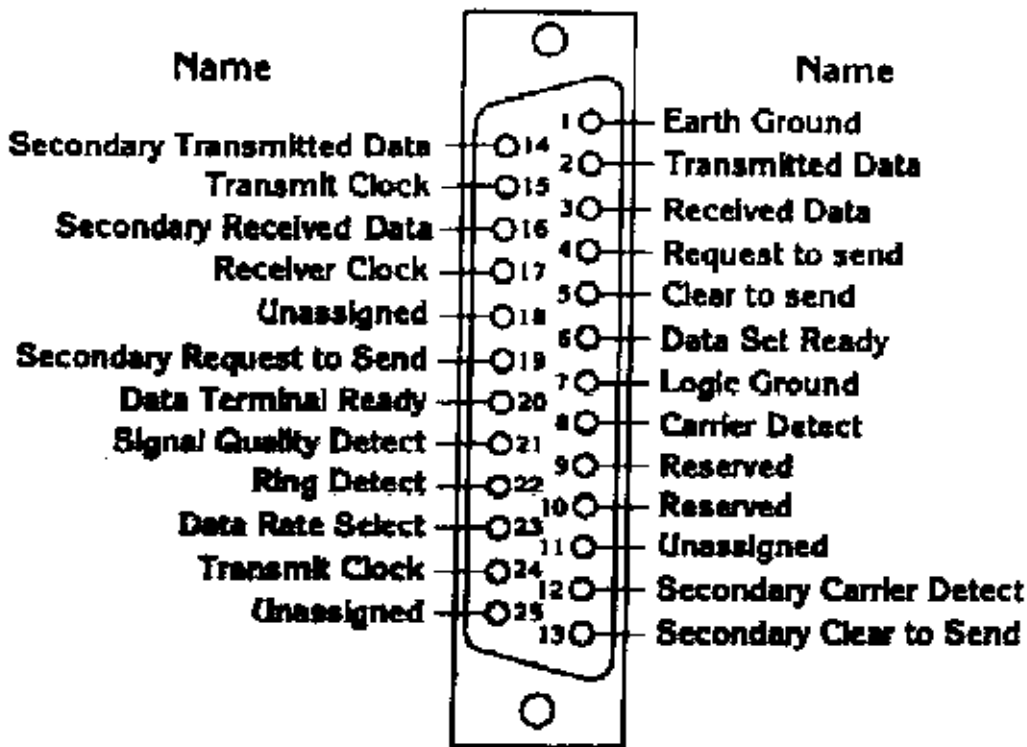

**RS232-C Serial Loopback Test Connector
(DB25P Plug)**

Serial Cable Information

The information in this section will help you make a serial cable to connect between the printer and computer.

Refer to the computer documentation to determine the cable requirements on the computers end.

The printer has the following cable requirements.

- Shielded, RS-232C cable
- UL and CSA approved
- No more than 50 feet long
- Cannon DB-25P plug (or equivalent) with 25 pins
- Cannon DB-C2-J9 (or equivalent) connector shell

Serial Interface Signal Requirements

Pin	Signal	Symbol	Direction	Description
1	Protective Ground	PG	Ground	Connected to the printer frame

2	Transmit Data	TD	From Printer	Serial data transmitted to the system
3	Receive Data	RD	To Printer	Serial data received by the printer
4	Request to Send	RTS	From Printer	Always set to low (mark)
5	Not Used			
6	Data Set Ready	DSR	To Printer	Indicates that data can be sent
7	Signal Ground	SG	Ground	Ground
8 to 10	Not Used			
11	Supervisory Send Data	SSD	From Printer	Indicates that the printer is not ready to receive data
12 to 19	Not Used			
20	Data Terminal Ready	DTR	From Printer	Indicates that the printer is not ready to receive data
21 to 25	Not Used			

Commonly Used Serial Cable Configurations

IBM 25-Pin Cable Configuration

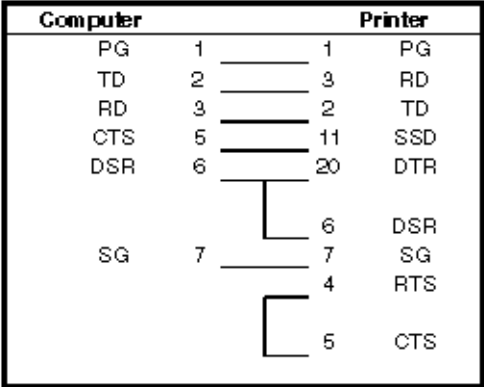

IBM 9-Pin Cable Configuration

Computer		Printer	
RD	2	2	TD
TD	3	3	RD
SG	5	7	SG
DSR	6	20	DTR
		6	DSR
CTS	8	11	SSD
		4	RTS
		5	CTS

Copyright 1997, Okidata, Division of OKI America, Inc. All rights reserved. See the OKIDATA Business Partner Exchange (BPX) for any updates to this material. (<http://bpx.okidata.com>)



Service Guide ML393/ML393CPlus

Chapter 4 Failure Analysis

4.8.05 Hexadecimal Dump

General Information

Hexadecimal Dump Mode allows you to test the data being sent from the computer to the printer.

When the printer is in Hex Dump Mode, all data received (including text and printer commands) will be printed in both hexadecimal and ASCII format.

NOTE:

In ASCII format, all non-printable characters are represented by a period.

Example

Below is a line of BASIC code.

```
LPRINT CHR$(27);"0";CHR$(30);"This is an example of hexadecimal dump."
```

Below is the same line as it would appear in Hex Dump Mode.

This is an example of a hexadecimal dump

```
1B 30 1E 54 68 69 73 20 69 73 20 61 6E 20 65 78 0.
```

```
61 6D 70 6C 65 20 66 20 61 20 68 65 78 61 64
```

```
65 63 69 6D 61 6C 20 64 75 6D 70 2E 0D 0A
```

Procedure

1. Verify that paper is loaded.
2. Verify that the ribbon is installed.
3. Power OFF the printer.
4. Press and hold SELECT and FORM FEED while powering ON the printer.
5. The printer will print the line shown below.

HEX DATA DUMP

6. The printer is ready to receive data in the Hexadecimal Dump Mode.
7. Send data to the printer.
8. To exit Hex Dump Mode, power OFF the printer.

Sample

```

Hex Data Dump
1B 7B 42 1B 74 91 1B 49 21 1B 26 1B 52 09 1B 7B
01 1B 19 30 1B 49 00 00 0D 1B 4A A8 1B 24 3C 00
1B 72 00 1B 55 01 1B 2A 27 49 02 00 00 30 00 00
30 00 00 30 00 00 30 00 00 30 00 00 30 00 00 3F
00 00 3F 00 00 30 00 00 30 00 00 30 00 00 30 00
00 30 00 00 30 00 00 30 00 00 00 00 00 00 3F 00 00
3F 00 00 00 00 00 00 00 00 00 00 00 00 01 00 00 01
00 00 01 00 00 00 00 00 00 00 00 00 00 00 00 00 00
00 00 00 00 00 00 00 00 00 00 00 00 00 00 00 00 00
01 00 00 01 00 00 01 00 00 01 00 00 01 00 00 00 00
00 00 00 00 00 00 00 00 00 00 00 00 00 00 00 00 00
00 00 0D 00 00 00 00 00 00 00 00 00 00 00 00 00 00
00 00 00 00 00 00 3F 00 00 3F 00 00 30 00 00 1F
00 00 07 00 00 00 00 00 00 00 00 00 00 00 00 00 00
00 00 00 00 00 00 00 00 00 00 00 00 07 00 00 1F 00 00
3E 00 02 3F 00 00 3F 00 00 00 00 00 00 00 00 00 00

00 00 00 00 00 31 00 00 31 00 00 00 00 00 00 00
00 00 00 00 00 00 00 00 00 00 00 00 00 00 01 00 00
01 00 00 01 00 00 01 00 00 01 00 00 01 00 00 00 00
00 00 00 00 00 00 00 00 00 00 00 00 00 00 01 00
00 01 00 00 00 00 00 01 00 00 01 00 00 01 00 00 00
00 00 00 00 00 00 00 00 00 00 00 00 00 01 00 00 01
00 00 01 00 00 01 00 00 01 00 00 01 00 00 00 00 00
00 00 00 00 00 00 00 00 00 00 00 00 00 00 00 00 00
3F 00 00 3F 00 00 00 00 00 00 00 00 00 00 00 00 00
00 00 51 00 00 31 00 00 00 00 00 00 00 00 00 00 00
00 00 00 00 01 00 00 01 00 00 00 00 00 00 00 00 00
01 00 00 01 00 00 01 00 00 01 00 00 01 00 00 00 00
00 00 00 00 00 00 00 00 00 00 00 00 00 00 00 00 00
00 00 00 00 00 00 01 00 00 01 00 00 01 00 00 01 00 00
01 00 00 01 00 00 00 00 00 00 00 00 00 00 00 00 00
00 00 00 00 00 00 00 00 00 00 00 00 00 00 00 00 00

00 00 00 00 00 00 00 00 00 00 00 00 0F 00 00
3F 00 00 30 00 00 00 00 00 00 00 00 00 00 00 00 00
00 00 30 00 00 30 00 00 30 00 00 00 00 00 00 00 00
00 00 00 00 00 00 00 00 00 00 1C 00 00 30 00 00
30 00 00 30 00 00 30 00 00 30 00 00 10 00 00 1C
00 00 0F 00 00 00 00 00 00 00 00 00 00 00 00 00 00
00 0F 00 00 1C 00 00 30 00 00 30 00 00 30 00 00 00
30 00 00 30 00 00 30 00 00 1C 00 00 0F 00 00 00 00
00 00 00 00 00 00 00 00 00 00 00 00 00 00 00 00 00
0F 00 00 3F 00 00 30 00 00 30 00 00 30 00 00 30 00
00 30 30 00 00 30 00 00 30 00 00 30 00 00 00 00 00
00 00 00 00 00 00 00 00 07 00 00 0F 00 00 1C 00 00
30 00 00 30 00 00 30 00 00 30 00 00 30 00 00 30 00 1F
00 00 1C 00 00 0F 00 00 00 00 00 00 00 00 00 00 00
00 00 00 00 00 00 00 00 03 00 00 07 00 00 0E 00 00

00 00 00 3F 00 00 3F 00 00 00 00 00 00 00 00 00 00
00 00 00 00 00 00 00 00 00 00 00 00 00 00 00 00 00
00 00 00 00 00 00 00 00 00 00 00 00 00 00 00 00 00

```

4.9 RESISTANCE CHECKS

4.9.01 General Information

The following resistance charts are included in this section.

Printhead Resistance

Line Feed Motor Resistance

Space Motor Resistance

Ribbon Motor Resistance

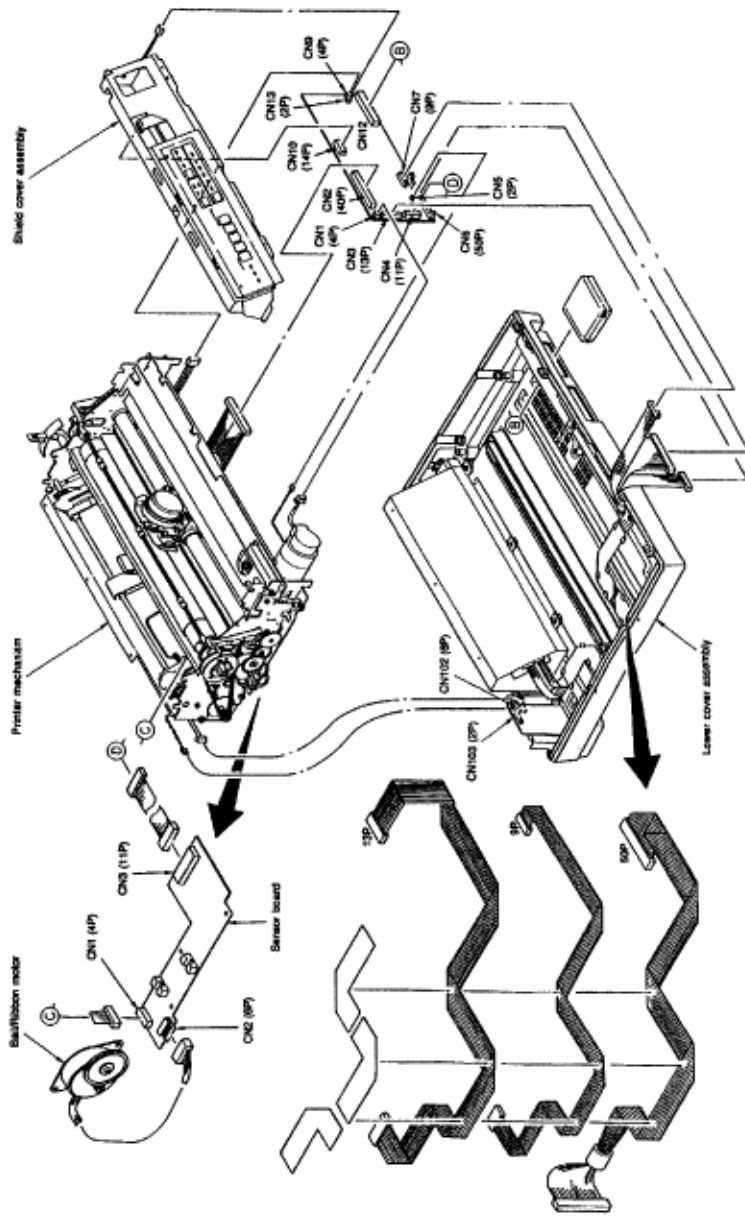

Copyright 1997, Okidata, Division of OKI America, Inc. All rights reserved. See the OKIDATA Business Partner Exchange (BPX) for any updates to this material. (<http://bpx.okidata.com>)



Service Guide ML393/ML393CPlus

Chapter 4 Failure Analysis

4.9.02 Printhead Resistance Check

The resistance of each coil should be about 4.5 ohms.

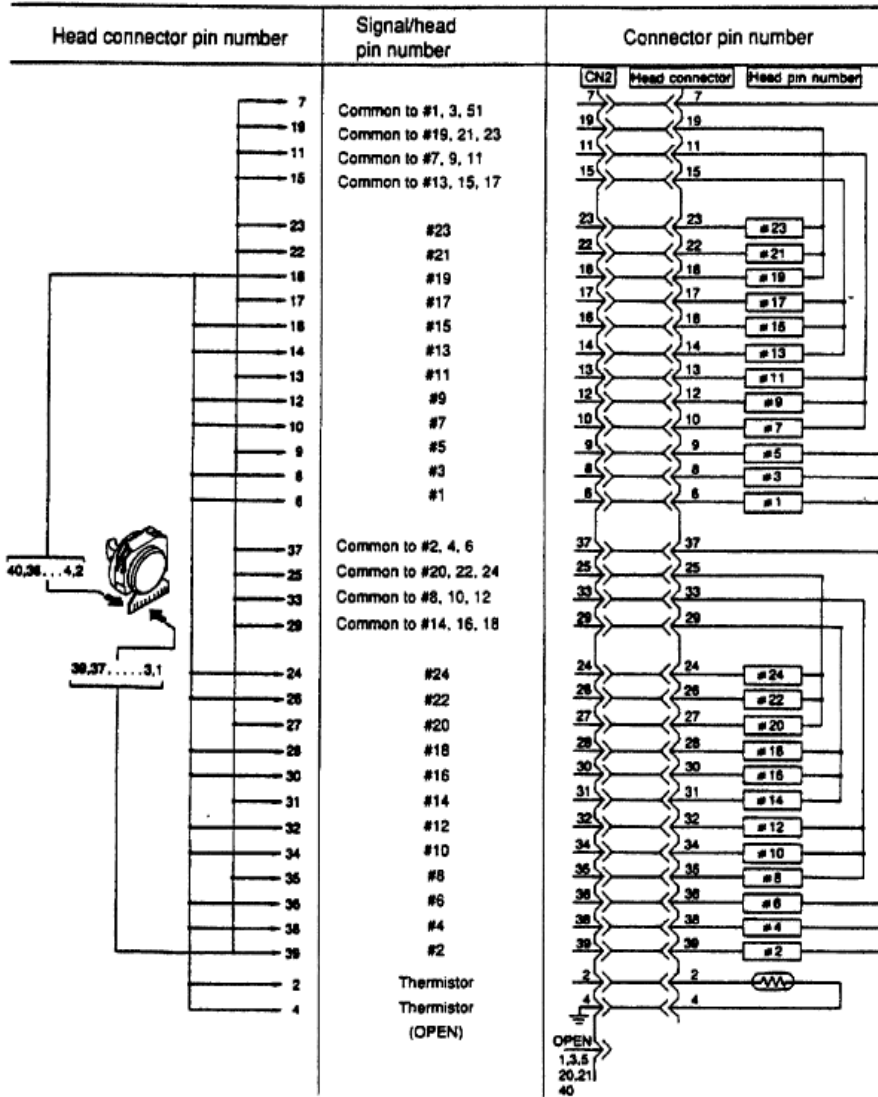



Service Guide ML393/ML393CPlus

Chapter 4 Failure Analysis

4.9.03 Line Feed Motor Resistance Check

The resistance of each coil should be about 5.6 ohms.

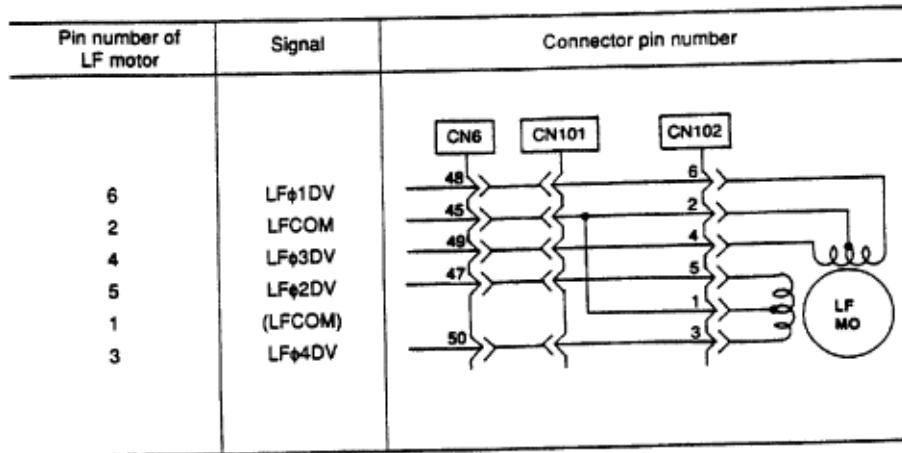

Copyright 1997, Okidata, Division of OKI America, Inc. All rights reserved. See the OKIDATA Business Partner Exchange (BPX) for any updates to this material. (<http://bpx.okidata.com>)



Service Guide ML393/ML393CPlus

Chapter 4 Failure Analysis

4.9.04 Space Motor Resistance Check

The resistance of the motor should be about 11.4 ohms.

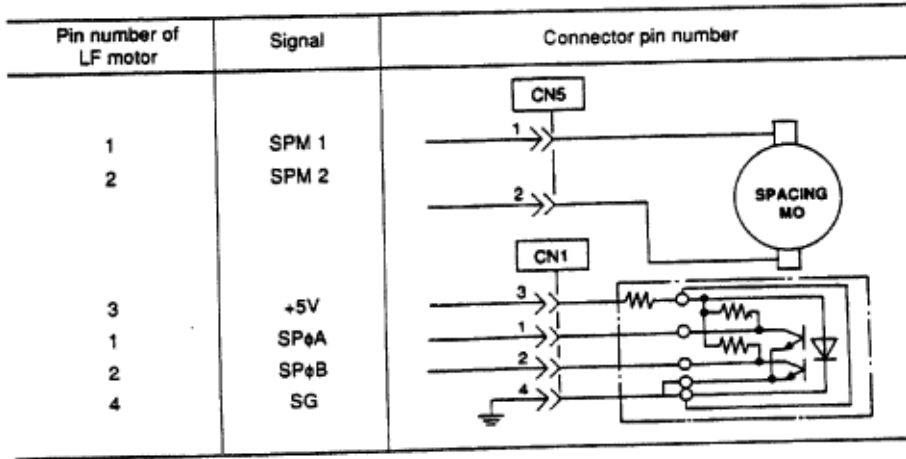

Copyright 1997, Okidata, Division of OKI America, Inc. All rights reserved. See the OKIDATA Business Partner Exchange (BPX) for any updates to this material. (<http://bpx.okidata.com>)



Service Guide ML393/ML393CPlus

Chapter 4 Failure Analysis

4.9.05 Ribbon Motor Resistance Check

The resistance of each coil should be about 34 ohms

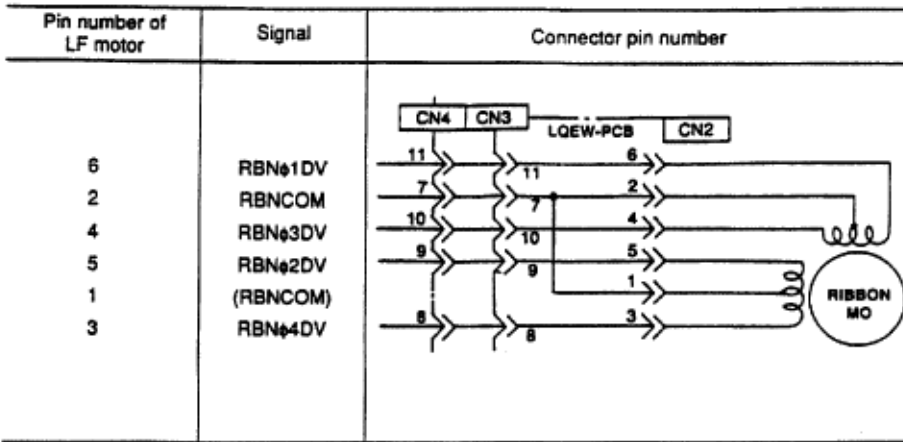



Service Guide ML393/ML393CPlus

Chapter A Board Diagrams

A.1 OVERVIEW

A.1.01 General Information

This section describes the characteristics of the printed circuit boards used in the unit.





The following areas are covered.

- Firmware
- Fuses
- Jumpers
- Sensors
- Switches
- Test Points

Where an item is not applicable, the word *NONE* will be listed.

Copyright 1997, Okidata, Division of OKI America, Inc. All rights reserved. See the OKIDATA Business Partner Exchange (BPX) for any updates to this material. (<http://bpx.okidata.com>)

A.2 INDEX TO CHARTS

Description	Board Designation	Section
Main Control Board	LQEM	A.2.01 
Power Supply	N/A	A.2.02 
Interface Connection Assembly	LQPN	A.2.03 
Sensor Board	LQEW or LPRW	A.2.04 
Operator Panel Board	LQSX	A.2.05 

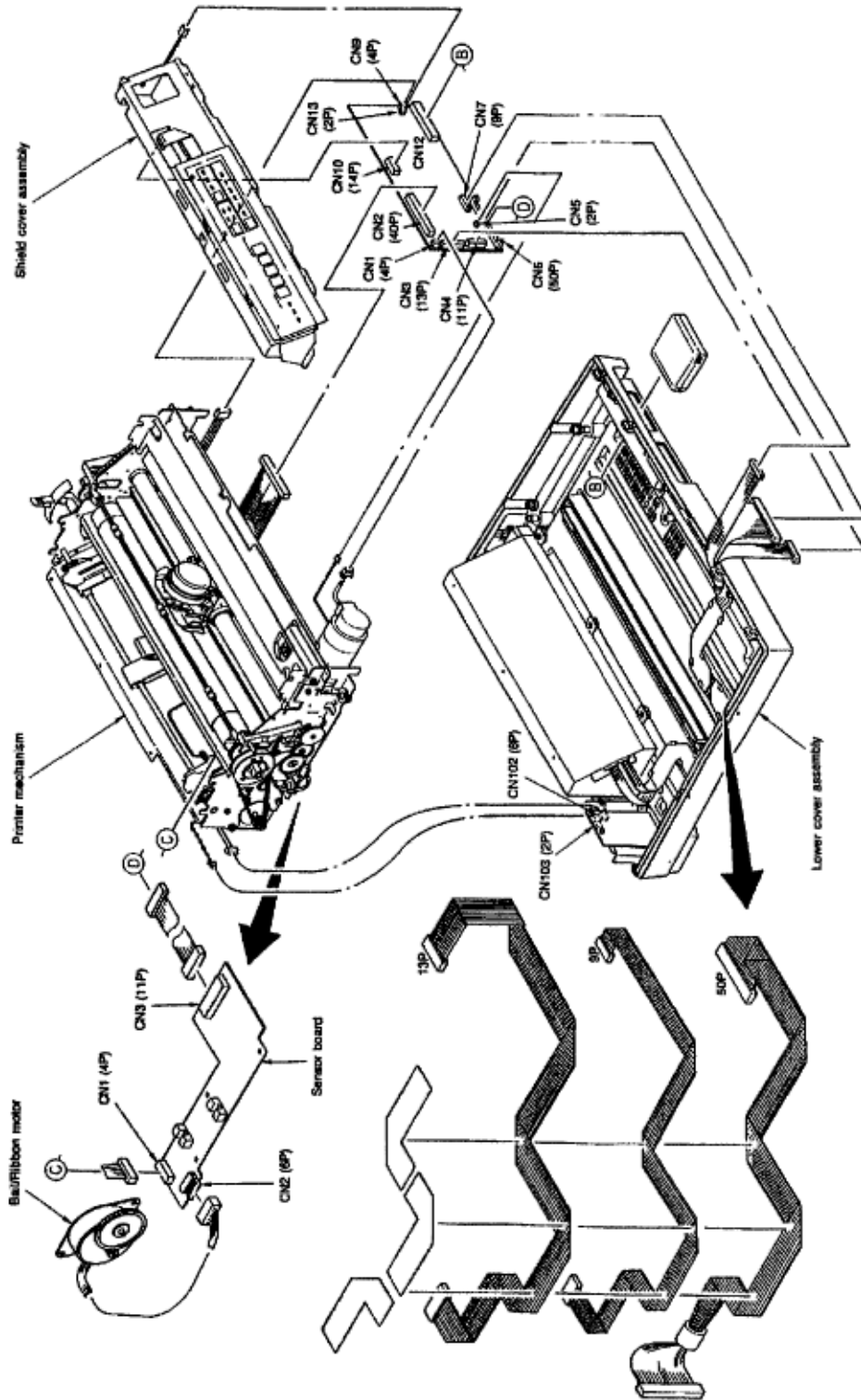

Copyright 1997, Okidata, Division of OKI America, Inc. All rights reserved. See the OKIDATA Business Partner Exchange (BPX) for any updates to this material. (<http://bpx.okidata.com>)



Service Guide ML393/ML393CPlus

Chapter A Board Diagrams

A.2.01 Main Control Board (LQEM)

Firmware

Q6 - Program ROM of Master MPU

Q7 - Character Generator ROM

Q17 - Program Rom of Slave MPU

Fuses

F1 2.0 Amp 125V

Jumpers

SP1: OPEN - Internal ROM

SHORTED - External ROM

SP3 OPEN - Monochrome Model

SHORTED - Color Model

Sensors

NONE

Switches

NONE

Test Points

+ 38vdc

Printhead, SP Motor, LF Motor and Bail/Ribbon motor drive voltage.

Check on both ends of Capacitor C2.

+ 5vdc

Logic IC/LED drive voltage.

Check between pin 16 of Q2 and the power bar.

+ 8vdc

Line feed motor holding voltage and serial interface line voltage.

Check on both ends of C9.

- 8vdc

Serial interface line voltage.

Check on both ends of C8.

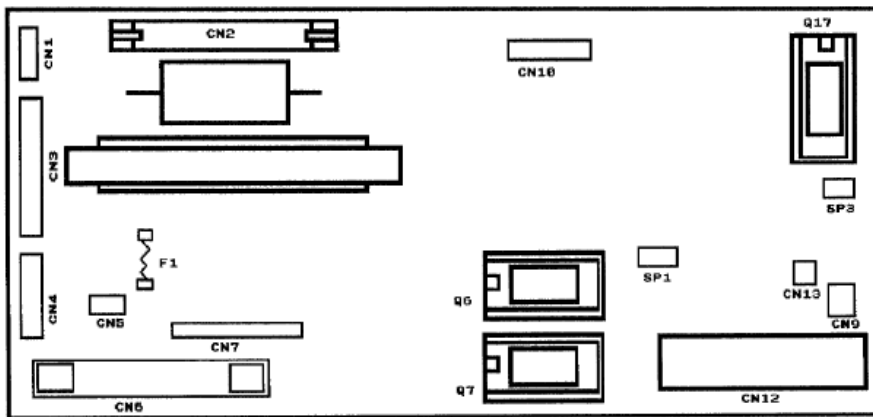

Copyright 1997, Okidata, Division of OKI America, Inc. All rights reserved. See the OKIDATA Business Partner Exchange (BPX) for any updates to this material. (<http://bpx.okidata.com>)



Service Guide ML393/ML393CPlus

Chapter A Board Diagrams

A.2.02 Power Supply

Firmware

NONE

Fuses

F1 10.0 Amp 125V

Jumpers

NONE

Sensors

NONE

Switches

NONE

Test Points

CN - 1 Pin 6 +38vdc

CN - 2

Pin 6 +8vdc

Pin 7 -8vdc

Pin 4 +5vdc

Pin 2 Signal Ground

Pin 3 Signal Ground

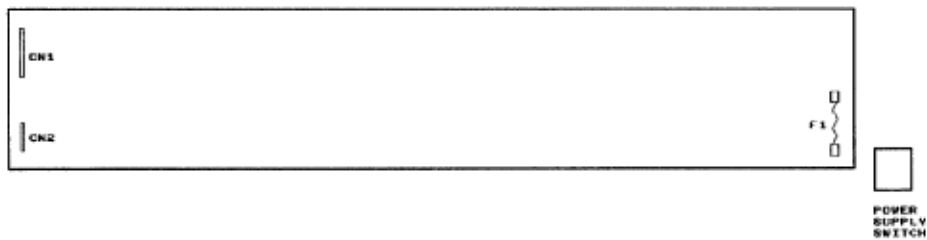

A.2.03 Interface Board (LQPN)**Fuses**

NONE

Jumpers

SP101

A Side: Auto Feed XT signal of Centronics interface valid

B Side: Auto Feed XT signal of Centronics interface invalid

SP102

A Side: I-Prime Signal of Centronics interface is valid

B Side: I-Prime Signal of Centronics interface is invalid

SP103

A Side: +5 vdc is output to pin 18 of Centronics interface.

B Side: +5 vdc is not output to pin 18 of Centronics interface.

Sensors

NONE

Switches

SW101 - This switch toggles for selecting either the serial or parallel interface.

Firmware

NONE

Test Points

NONE

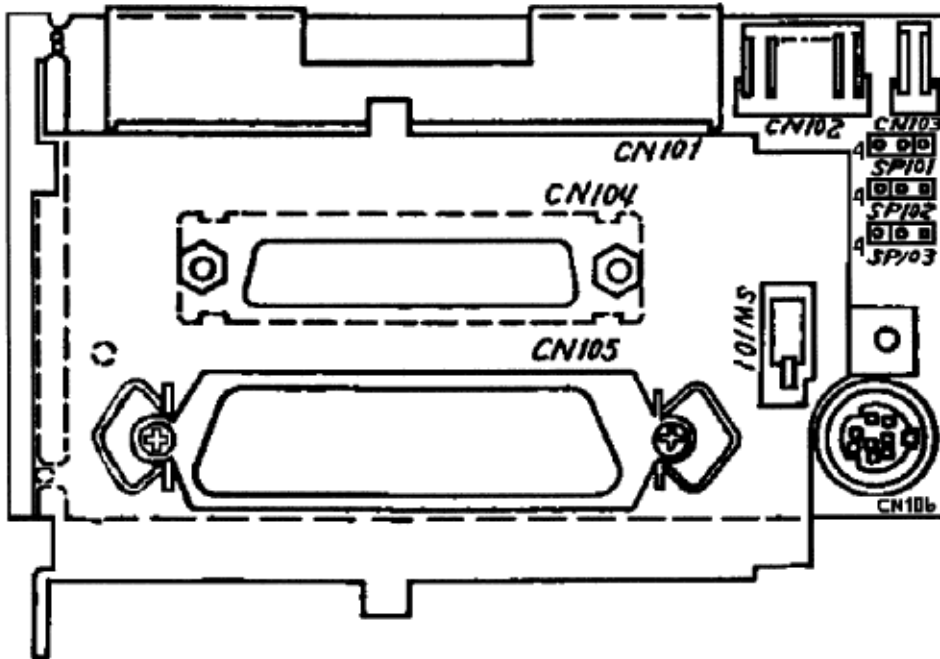

Copyright 1997, Okidata, Division of OKI America, Inc. All rights reserved. See the OKIDATA Business Partner Exchange (BPX) for any updates to this material. (<http://bpx.okidata.com>)

A.2.04 Sensor Board (LQEW or LPRW)

Firmware

NONE

Fuses

NONE

Jumpers

NONE

Sensors

Bottom Paper Sensor

Bail Arm Sensor

Ribbon Shift Sensor

Located on sensor board in color model *only*

CN1

Connector for Friction Feed Paper Photosensor (located on the Paper Pressure Guide)

Switches

NONE

Test Points

NONE

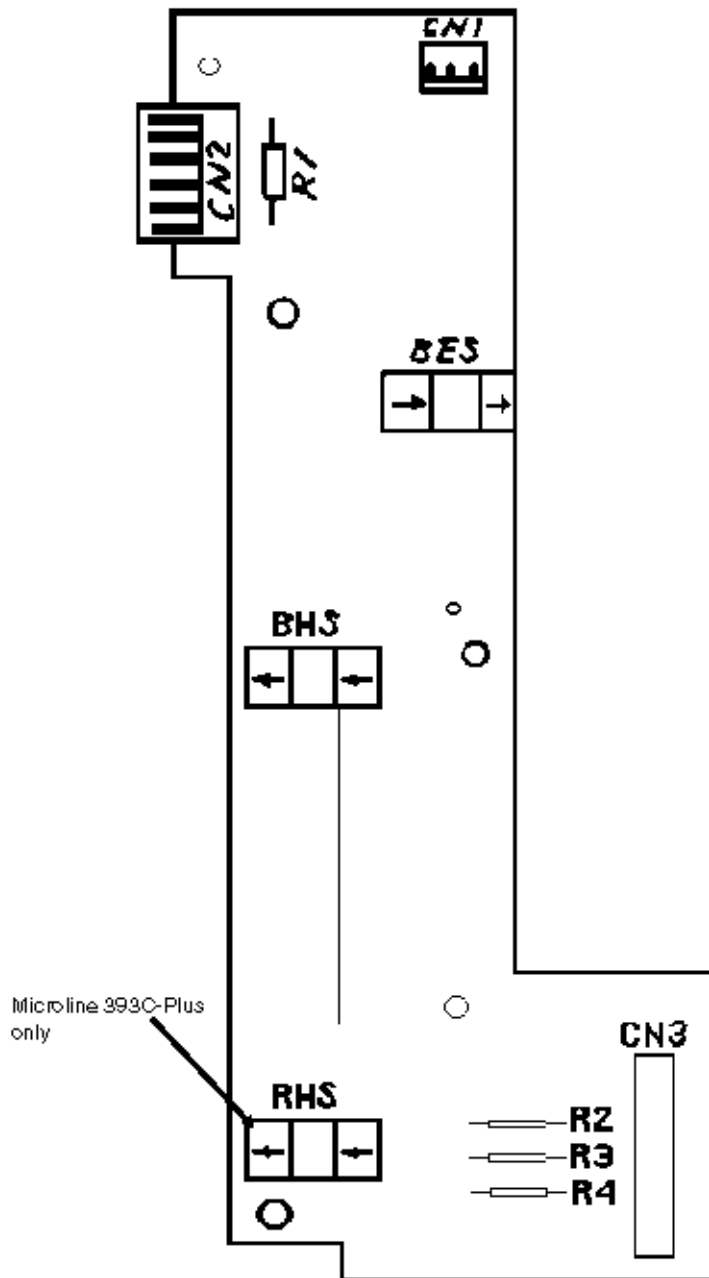

Copyright 1997, Okidata, Division of OKI America, Inc. All rights reserved. See the OKIDATA Business Partner Exchange (BPX) for any updates to this material. (<http://bpx.okidata.com>)



Service Guide ML393/ML393CPlus

Chapter A Board Diagrams

A.2.05 Operator Panel Board (LQSX)

Firmware

NONE

Fuses

NONE

Jumpers

NONE

Sensors

NONE

Switches

NONE

Test Points

NONE

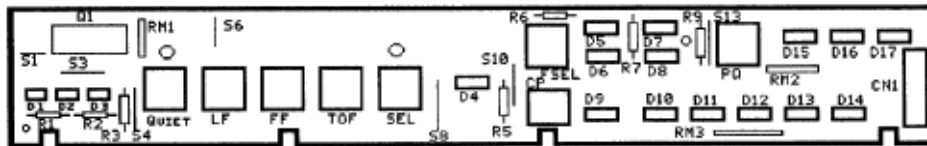

Copyright 1997, Okidata, Division of OKI America, Inc. All rights reserved. See the OKIDATA Business Partner Exchange (BPX) for any updates to this material. (<http://bpx.okidata.com>)



Service Guide ML393/ML393CPlus

Chapter B Illustrated Parts Listing

B.1 OVERVIEW

B.1.01 General Information

This appendix will assist you in identifying the assemblies and parts of the product.

Use Section Four (Failure Analysis) to determine the defective part(s).

Locate the part and its part number in this section.

Appendix B is cross-referenced to Section Three (Maintenance).

Format

The format for this appendix is a series of tables with diagrams. The tables contain the item reference number, the Okidata and Oki-Japan (Oki-J) part numbers, the part description, a comments section, and the disassembly procedure.

Item	Okidata P/N Oki-J P/N	Description	Comments Refer to B.1.02	Disassembly Procedure
------	--------------------------	-------------	-----------------------------	--------------------------

Items with the comments RSPL (Recommended Spare Parts List), Consumable, Document, or Option are available from Okidata. Items without these comments are usually not stocked.

Some items are only available as assemblies. Every effort has been made to clearly indicate which items are in assemblies and which are not.

N/A will appear where a part number is not available.

Current Part Numbers

Okidata has made every effort to include current part numbers in this Service Handbook *at the time of publishing*.

However, technical information frequently changes. These changes often include new or modified parts, with new or modified part numbers.

Please refer to the following resources for current part numbers and pricing.

- Okidata's Electronic Bulletin Board (Okilink II) contains current part numbers, prices, and recommended stocking levels for each item listed as a recommended spare part. For instructions on accessing Okilink II, refer to the Service Center Reference Guide.
- Okidata's Faxable Facts is an automated fax document retrieval system. Part numbers and pricing are available through Faxable Facts. For instructions on accessing Faxable Facts, refer to the Service Center Reference Guide.
- Okidata's Technical Information Group is a telephone support line reserved for Authorized Dealers. Part numbers and pricing are available through Technical Information. For instructions on accessing Technical Information, refer to the Service Center Reference Guide.

REMEMBER

Current part numbers, recommended stocking levels, and pricing information are available through

Okilink II, Faxable Facts, and Technical Information. Refer to the Service Center Reference Guide for information on accessing these resources.

Copyright 1997, Okidata, Division of OKI America, Inc. All rights reserved. See the OKIDATA Business Partner Exchange (BPX) for any updates to this material. (<http://bpx.okidata.com>)



Service Guide ML393/ML393CPlus

Chapter B Illustrated Parts Listing

B.1.02 Definition of Terms

Assemblies

Assemblies are parts grouped under a single description and/or part number. Generally, individual items in an assembly are not available from Okidata.

Assemblies are surrounded by broken line boxes in the diagrams.

Assemblies will say "Includes xx xx" under the *Comments* section of the tables.

Parts in assemblies will say "Part of xx" under the *Comments* section of the tables.

Blank

Okidata does not recommend stocking this item. This item should be purchased on an As Required Basis *only*.

The availability of this item is *NOT* guaranteed by Okidata.

Consumable

A consumable is a supply item which has a specified life and must be periodically replaced. It is purchased and installed by the end user. Okidata machines are designed to work *exclusively* with Okidata consumables. By using genuine Okidata consumable products, the investment made in the equipment is protected.

Document

A document is a printed item which supports the service and marketing of a product. Various documents are available from Okidata.

Drivers

Printer drivers are updated frequently. Please refer to Okilink II for the latest printer driver information.

Firmware

Firmware is revised frequently. Please refer to Okilink II for the latest firmware information.

Option

An option is a part/assembly which is added to a product. The option expands the products functionality. An option may or may not be installed by the end user. Instructions for installation accompany each option.

Option RSPL

Okidata recommends that this part/assembly be on hand for servicing installed options.

RSPL

Okidata recommends that this part/assembly be on hand for servicing.

Technical Service Bulletins

Technical Service Bulletins (TSBs) are also referred to as Okidata's monthly mail.

The TSBs contain the latest information on firmware revisions, procedure changes, and technical information updates.

Okidata distributes the TSBs through Okilink II. The TSBs are issued monthly.

Copyright 1997, Okidata, Division of OKI America, Inc. All rights reserved. See the OKIDATA Business Partner Exchange (BPX) for any updates to this material. (<http://bpx.okidata.com>)



Service Guide ML393/ML393CPlus

Chapter B Illustrated Parts Listing

B.1.03 Parts Ordering Information

Service Center Reference Guide

When a technician has successfully completed a Service Training Course for a product and the Dealer has become Service Authorized, an information package is provided to the Dealer. The Okidata Service Center Reference Guide outlines the following items.

- Responsibilities of Okidata Service Centers
- Spare parts and consumables information
- Procedures for warranty repairs
- Product Training, Certification, and Authorization
- Product Support information
- Okidata Depot information and services
- Third Party Service information
- Information about Okidata's Customer Information Center
- Okidata Service and Support telephone numbers.

The Service Center Reference Guide contains the procedures to follow for ordering parts. Please *read, understand, and follow* these procedures. Service Authorization for a specific product *must* be obtained before a Dealer can submit warranty claims.

Direct questions regarding the Service Center Reference Guide to Okidata Dealer Service. Refer to the Service Center Reference Guide for information on contacting Okidata.

Placing a Parts Order

All authorized Okidata resellers may order spare parts and consumables for Okidata products. Orders are placed through Okidata's Order Processing Center Department.

Please refer to your Service Center Reference Guide for details on ordering parts.

You should have the following information available *before* you place your order.

- Okidata Dealer Authorization Number
- Okidata Customer Number
- Your Purchase Order Number
- Okidata Part Number(s)

Use this Appendix, Okilink II, Faxable Facts, or contact Okidata Technical Support to find the correct part number. Refer to the Service Center Reference Guide for information on contacting Okidata.



Service Guide ML393/ML393CPlus

Chapter B Illustrated Parts Listing

B.2 CHARTS

Below is an index to the illustrated parts breakdown charts.

Description	Section
Printer Unit	B.2.01
Upper Cover Assembly	B.2.02
Printer Unit General Assembly (1 of 2)	B.2.03
Printer Unit General Assembly (2 of 2)	B.2.04
Operator Panel Assembly	B.2.05
Printer Mechanism - Monochrome (1 of 3)	B.2.06
Printer Mechanism - Monochrome (2 of 3)	B.2.07
Printer Mechanism - Monochrome (3 of 3)	B.2.08
Printer Mechanism - Color (1 of 3)	B.2.09
Printer Mechanism - Color (2 of 3)	B.2.10
Printer Mechanism - Color (3 of 3)	B.2.11
Carriage Assembly - Monochrome	B.2.12
Carriage Assembly - Color	B.2.13
Options	B.2.14
Pull Tractor Unit Assembly (Option)	B.2.15
Packing Materials	B.2.16
Consumables	B.2.17
Documentation	B.2.18
Service Training Kit Revisions	B.2.19





Service Guide ML393/ML393CPlus

Chapter B Illustrated Parts Listing

B.2.01 Printer Unit

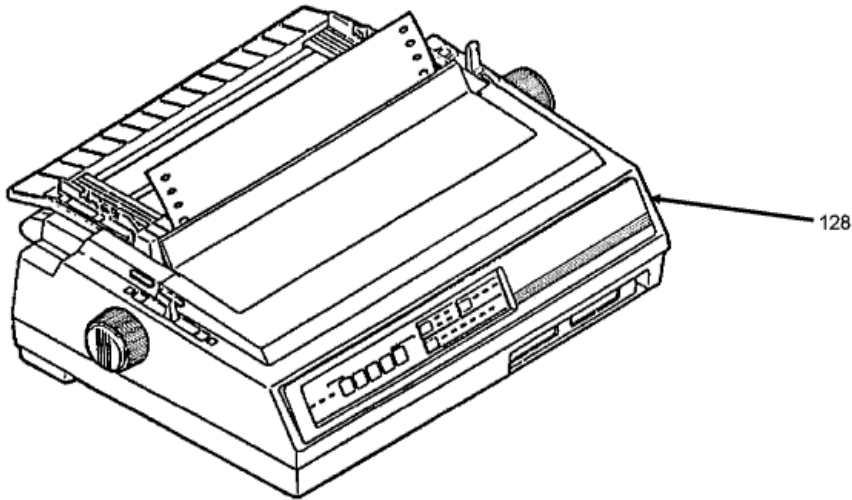
Part numbers are subject to change. Refer to Okilink II for current part numbers and pricing information.



Item	Okidata P/N Oki-J P/N	Description	Comments Refer to B.1.02 	Disassembly Procedure
128	62405001 N/A	Printer: Microline 393 Epson Black 120 V		N/A
128	62405002 N/A	Printer: Microline 393 Epson Black 220/240 V		N/A
128	62405003 N/A	Printer: Microline 393 Epson/IBM Black 120 V		N/A
128	62405101 N/A	Printer: Microline 393C Epson Color 120 V		N/A
128	62405102 N/A	Printer: Microline 393C Epson/IBM Color 220/240 V		N/A

128	62405103 N/A	Printer: Microline 393C Epson/IBM Color 120 V		N/A
128	62408201 N/A	Printer: Microline 393-Plus Black 120 V		N/A
128	62408202 N/A	Printer: Microline 393-Plus Black 220 V		N/A
128	62408301 N/A	Printer: Microline 393C-Plus Color 120 V		N/A
128	62408302 N/A	Printer: Microline 393C-Plus Color 220 V		N/A

Copyright 1997, Okidata, Division of OKI America, Inc. All rights reserved. See the OKIDATA Business Partner Exchange (BPX) for any updates to this material. (<http://bpx.okidata.com>)









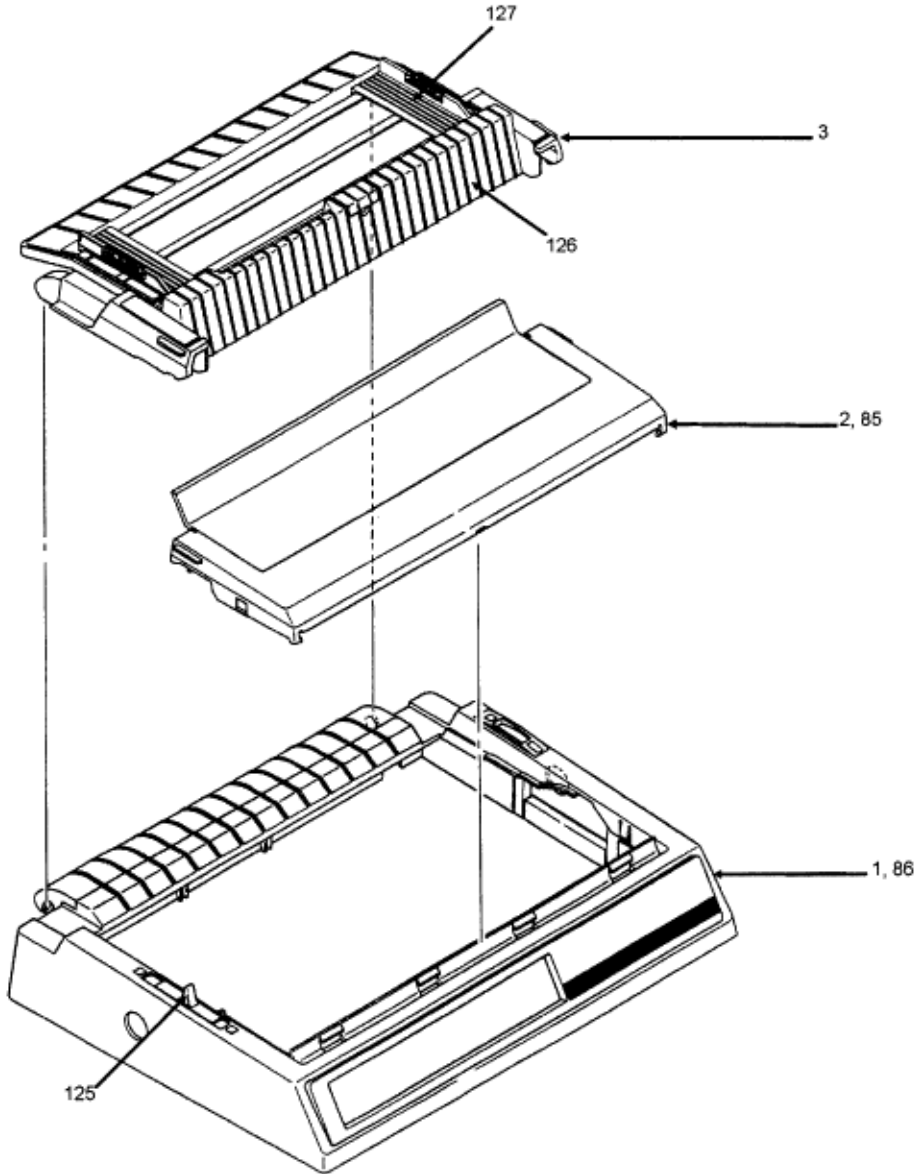

Service Guide ML393/ML393CPlus
 Chapter B Illustrated Parts Listing

B.2.02 Upper Cover Assembly

Part numbers are subject to change. Refer to Okilink II for current part numbers and pricing information.



Item	Okidata P/N Oki-J P/N	Description	Comments Refer to B.1.02 	Disassembly Procedure
------	--------------------------	-------------	--	--------------------------

1	50212427 2PA4016-4723G27	Cover: Middle (ML393+)	RSPL	3.2.04 
2	50212306 2PA4016-6062G6	Cover: Access (Monochrome)	RSPL	3.2.04 
3	50212504 2PA4016-4725G4	Cover: Rear	RSPL	3.2.04 
85	50212307 2PA4016-6062G7	Cover: Access (Color)	RSPL	3.2.04 
86	50212426 2PA4016-4723G26	Cover: Middle (ML393C+)	RSPL	3.2.04 
125	53482901 N/A	Lever: Bail		3.2.04 
126	51001901 N/A	Separator: Paper		3.2.04 
127	53482801 N/A	Guide: Sheet Insertion		3.2.04 

Copyright 1997, Okidata, Division of OKI America, Inc. All rights reserved. See the OKIDATA Business Partner Exchange (BPX) for any updates to this material. (<http://bpx.okidata.com>)



Service Guide ML393/ML393CPlus

Chapter B Illustrated Parts Listing

B.2.03 Printer Unit General Assembly (1 of 2)

Part numbers are subject to change. Refer to Okilink II for current part numbers and pricing information.

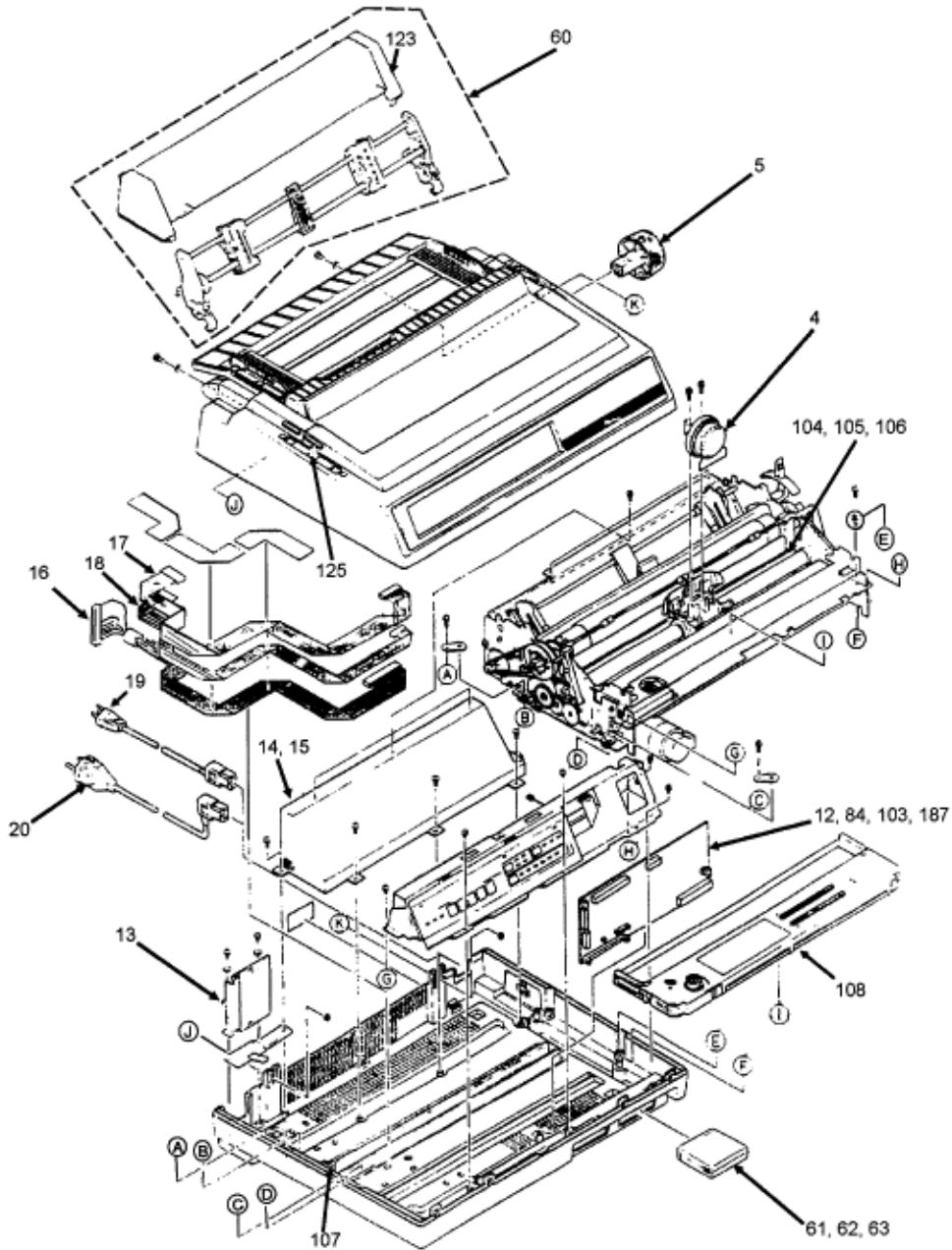

Item	Okidata P/N Oki-J P/N	Description	Comments Refer to B.1.02 	Disassembly Procedure
4	50054202 4YA4023-1100G1	Printhead: (Mylar Comp)	RSPL	3.2.01 
5	53478601 3PP4043-2501P1	Knob: Platen	RSPL	3.2.04 
12 *	55050411 4YA4042-1460G11	PCB: Main (LQEM-1) Black	RSPL	3.2.06 
13	55034501 4YA4042-1293G11	PCB: LQPN-Interface Connection [Assembly]	RSPL	3.2.07 
14	56406202 4YB4049-1277P2	Power Supply Assembly (220 vac)	RSPL	3.2.22 
15	56411201 4YB4049-1709P1	Power Supply Assembly (120 vac)	RSPL	3.2.22 
16	56619201 3YS4011-7912G1	Cord: I/F Main PCB Connection (50 Pin)	RSPL	3.2.06  , 3.22 
17	56614101 4YS4011-6295G1	Cord: Power Connection (9 Pin)	RSPL	3.2.22 
18	56614801 4YS4011-6253G3	Cord: Power Connection (13 Pin)	RSPL	3.2.22 
19	56609701 3YS4011-1315P1	Cord: AC Power (120 vac)	RSPL	3.2.01 
20	56624101 3YS4011-1265P1	Cable: AC 220V (ML) Right Ang	RSPL	3.2.01 
60	70011701 2PA4016-4722G4	Pull Tractor Assembly w/ Acoustic Cover	Option	N/A
61	70010201 4YA4042-1301G101	Gothic Font Cartridge	Option	3.2.04 
62	70010101 4YA4042-1301G102	Prestige Font Cartridge	Option	3.2.04 
63	70016401 4YA4042-1470G101	Cartridge: 32 Kbyte RAM Expansion	Option	3.2.04 

* When replacing the main control board, be sure to remove any socketed PROMS and EEPROMS. Replacement printed circuit boards are shipped WITHOUT these items. When removing PROMs and EEPROMs, you MUST follow standard Electrostatic Sensitive Device (ESD) safety precautions or you may damage the components.

Copyright 1997, Okidata, Division of OKI America, Inc. All rights reserved. See the OKIDATA Business Partner Exchange (BPX) for any updates to this material. (<http://bpx.okidata.com>)



Service Guide ML393/ML393CPlus

Chapter B Illustrated Parts Listing

B.2.04 Printer Unit General Assembly (2 of 2)

Part numbers are subject to change. Refer to Okilink II for current part numbers and pricing information.

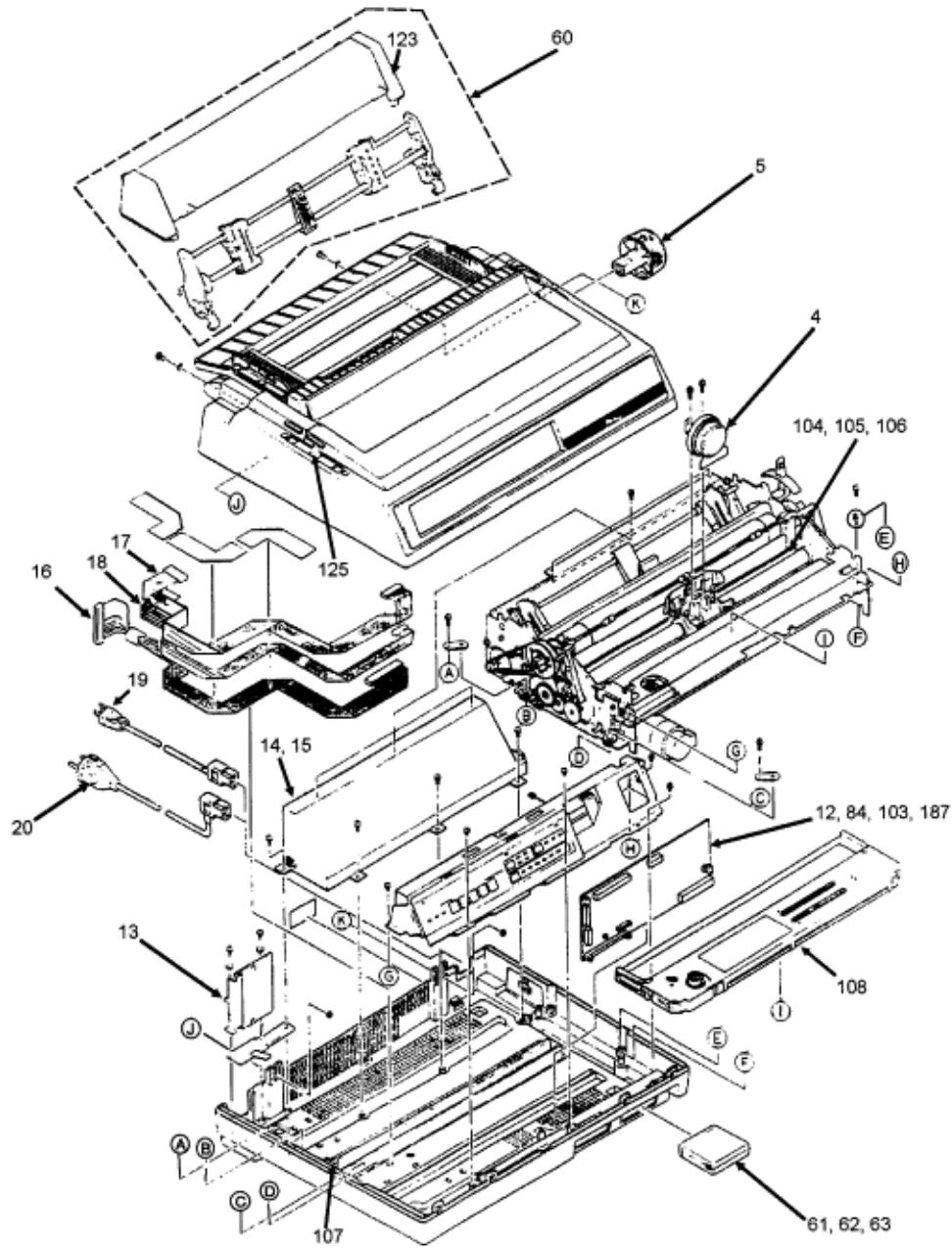

Item	Okidata P/N Oki-J P/N	Description	Comments Refer to B.1.02 	Disassembly Procedure
84 **	55050412 4YA4042-1460G12	PCB: Main (LQEM-2) Color	RSPL	3.2.06 
103	55938501 816A0326M000	IC: EEPROM BR93CS46-2-NW	RSPL	3.2.06 
104 *	51007701 3PB4043-4357P1	Guide: Bottom (Mylar)		N/A
105 *	51007601 N/A	Guide: Cut Sheet (Mylar)		N/A
106 *	51007801 N/A	Guide: Bottom Plate (Mylar)		N/A
107	51007901 3PB4043-4227P1	Base: (Mylar) Bottom Rear Guide		N/A
108	52103601 N/A	Cartridge: Ribbon (Black)	Consumable	3.2.01 
108	52103701 N/A	Cartridge: Ribbon (Color)	Consumable	3.2.01 
108	52103801 N/A	Cartridge: Film Ribbon (Black)	Consumable	3.2.01 
123	50212601 3PA4016-4722G1	Cover: Acoustic (Pull Tractor)	Option	N/A
123	50212604 2PA4016-4722G4	Cover: Acoustic (Pull Tractor)	Option RSPL	N/A
125	53482901 N/A	Lever: Bail		3.2.04 
187	56301703	Fuse: 2A 125 V		3.2.06 

* Items 104, 105, and 106 are in the same location.

Item 104, Bottom Guide (Mylar) is the largest mylar sheet.

Item 105, Cut Sheet Guide (Mylar) is the smallest mylar sheet.

Item 106, Bottom Guide Plate (Mylar) is the mylar sheet which extends from the bottom of the printer mechanism.

** When replacing the main control board, be sure to remove any socketed PROMS and EEPROMS.

Replacement printed circuit boards are shipped WITHOUT these items.

When removing PROMs and EEPROMs, you MUST follow standard Electrostatic Sensitive Device (ESD) safety precautions or you may damage the components.

B.2.05 Operator Panel Assembly

Part numbers are subject to change. Refer to Okilink II for current part numbers and pricing information.

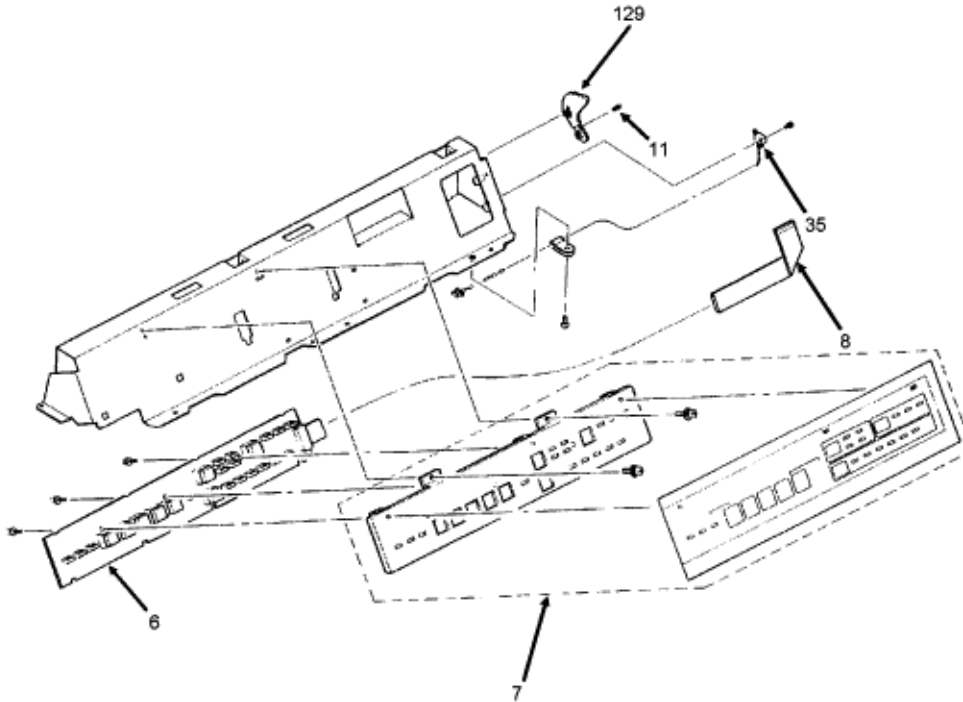

Item	Okidata P/N Oki-J P/N	Description	Comments Refer to B.1.02	Disassembly Procedure
6	55050601 4YA4042-1473G1	PCB: Operator Panel (LQSX)	RSPL	3.2.05
7	53479103 3PP4043-2712G3	Panel: Operator	RSPL	3.2.05
8	56614608 LP-5466-8	Cable: Operator Panel	RSPL	3.2.05
11	50910505 4LB-192200-5	Spring: Cover Open	RSPL	3.2.05
35	56614301 4YX4043-2759G1	Cable: Microswitch (Cover Open)	RSPL	3.2.05 19

129	53535301 3PP4016-5387P1	Lever: Cover Open		3.2.05
-----	----------------------------	-------------------	--	--------

Copyright 1997, Okidata, Division of OKI America, Inc. All rights reserved. See the OKIDATA Business Partner Exchange (BPX) for any updates to this material. (<http://bpx.okidata.com>)



Service Guide ML393/ML393CPlus

Chapter B Illustrated Parts Listing

B.2.06 Printer Mechanism - Monochrome (1 of 3)

Part numbers are subject to change. Refer to Okilink II for current part numbers and pricing information.

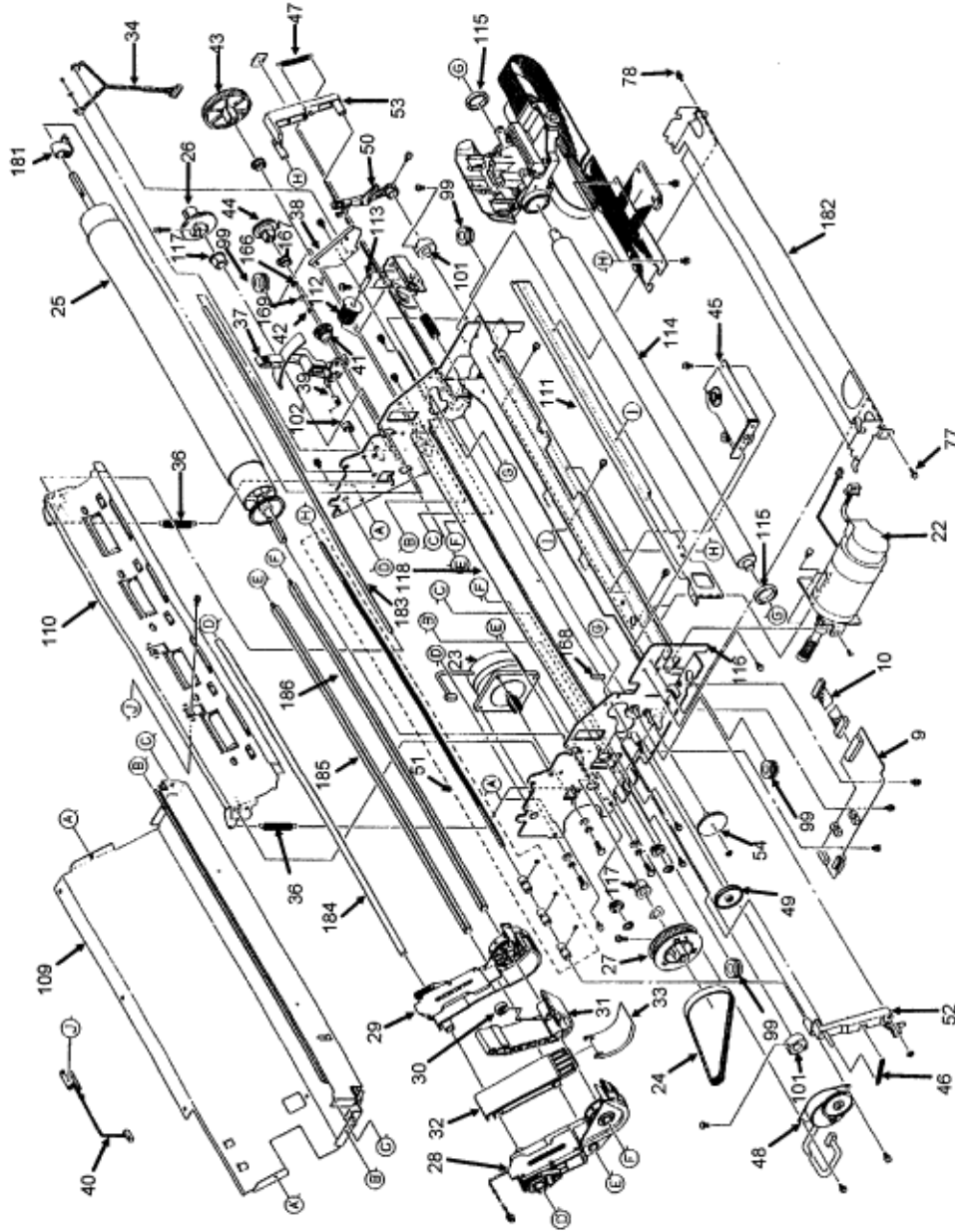

Item	Okidata P/N Oki-J P/N	Description	Comments Refer to B.1.02 	Disassembly Procedure
9	55050501 4YA4042-1462G1	PCB: Sensor (LQEW or LPRW)	RSPL	3.2.12 
10	56619101 4YS4011-4321P1	Cable: Sensor Board Connection	RSPL	3.2.12 
22	56506201 3YX4043-2550G1	Motor: Space Assembly	RSPL	3.2.14 
23	56508401 3PB4043-3853P1	Motor: Line Feed Assembly	RSPL	3.2.10 
24	51302790 4LP-1313-239	Belt: Mini Pitch (Line Feed)	RSPL	3.2.09 
25	50054101 4PA4043-2556G1	Platen: (Assembly)	RSPL	3.2.09 
26	51214501 3PP4043-2466P1	Gear: Platen - A	RSPL	3.2.09 
27	51215001 4PP4043-2465G1	Pulley: Platen	RSPL	3.2.09 
28	50054501 3YX4043-2561G1	Tractor: Push (Left) Assembly	RSPL	3.2.21 
29	50054601 3PA4043-2562G1	Tractor: Push (Right) Assembly	RSPL	3.2.21 
30	51002301 4PP4043-2451P1	Friction: Piece	RSPL	3.2.21 
31	51002401 3PP4043-2452P1	Guide: Center Upper	RSPL	3.2.21 
32	51002501 3PP4043-2453P1	Guide: Center Lower - A	RSPL	3.2.21 
33	51002601 3PP4043-2454P1	Guide: Center Lower - B	RSPL	3.2.21 
34	56209901 4YX4043-2784G1	Switch: Micro (Adj and Rel Lever)	RSPL	3.2.20 
36	50907502 4LB-193400-1	Spring: (Paper Chute)	RSPL	3.2.19 
37	53478706 3PP4043-2459P6	Lever: Release	RSPL	3.2.19 

Copyright 1997, Okidata, Division of OKI America, Inc. All rights reserved. See the OKIDATA Business Partner Exchange (BPX) for any updates to this material. (<http://bpx.okidata.com>)



Service Guide ML393/ML393CPlus

Chapter B Illustrated Parts Listing

B.2.07 Printer Mechanism - Monochrome (2 of 3)

Part numbers are subject to change. Refer to Okilink II for current part numbers and pricing information.

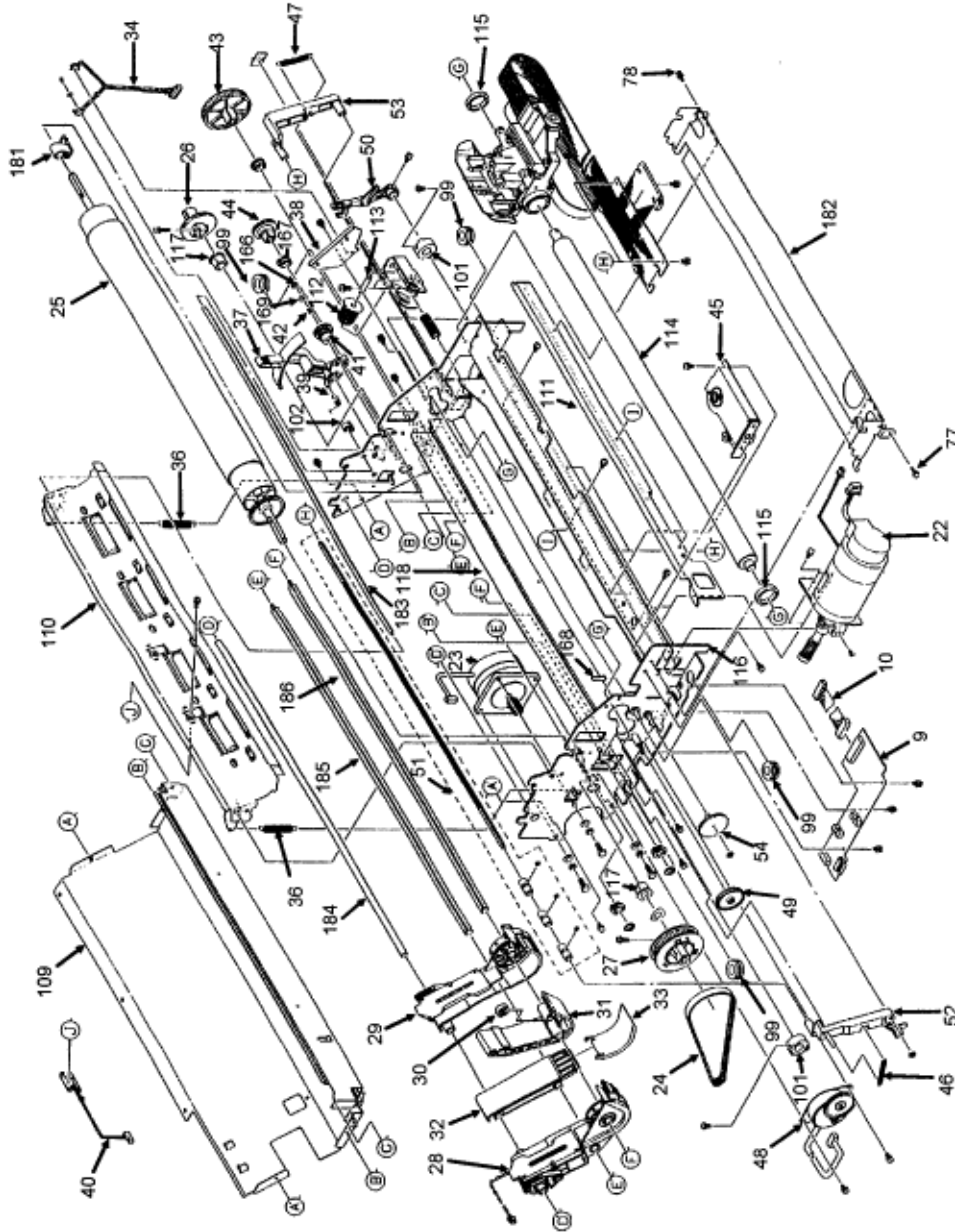

Item	Okidata P/N Oki-J P/N	Description	Comments Refer to B.1.02 	Disassembly Procedure
38	53063801 3PP4043-4224P1	Bracket: PH Gap Indication		3.2.20 
39	50910201 4PB4043-2754P1	Spring: Detent (Release Lever)	RSPL	3.2.19 
40	55034801 4YX4043-2576G1	Sensor: Cut-Sheet Paper-End	RSPL	3.2.19 
41	51214401 4PP4043-2458P1	Gear: Idle (Release Lever)	RSPL	3.2.09 
42	50910305 4LB-190600-6	Spring: Idle Gear	RSPL	3.2.09 
43	51214201 4PP4043-2456P1	Gear: Drive - A	RSPL	3.2.21 
44	51214301 4PP4043-2457P1	Gear: Drive - B	RSPL	3.2.21 
45	50054301 4PA4043-2584G1	Assembly: Ribbon Feed	RSPL	3.2.13 
46	50910701 4PP4043-2628P1	Spring: Bail Arm (Left)	RSPL	3.2.17 
47	50910801 4LB-193100-2	Spring: Bail Arm (Right)	RSPL	3.2.17 
48	56506301 3PP4043-2601P1	Motor: Step (Bail Arm) Assembly	RSPL	3.2.16 
49	51210201 5LR-193134-1	Gear: Idle (Bail Arm)	RSPL	3.2.17 
50	53478401 3PP4043-2504P1	Lever: Printhead Gap Adjust	RSPL	3.2.18 
51	50054401 4PA4043-2711G1	Assembly: Indicator Shaft	RSPL	3.2.17 
52	53478501 3PP4043-2509P1	Arm: Left Bail	RSPL	3.2.17 
53	53478502 3PP4043-2510P1	Arm: Right Bail	RSPL	3.2.17 
54	51214701 3PP4043-2764P1	Cam: Bail Open (Black)	RSPL	3.2.17 

Partner Exchange (BPX) for any updates to this material. (<http://bpx.okidata.com>)









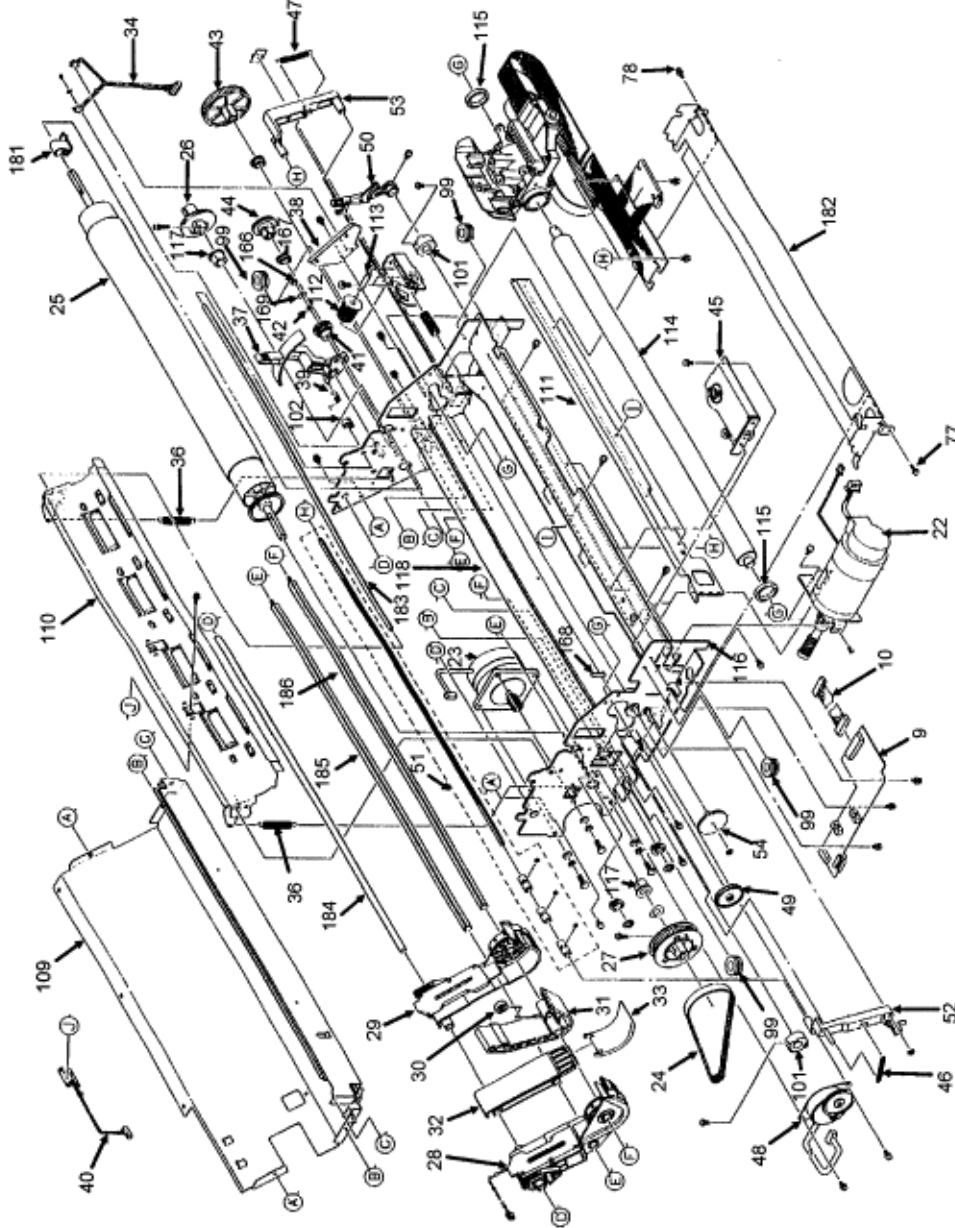

Service Guide ML393/ML393CPlus



Chapter B Illustrated Parts Listing

B.2.08 Printer Mechanism - Monochrome (3 of 3)

Part numbers are subject to change. Refer to Okilink II for current part numbers and pricing information.



Item	Okidata P/N Oki-J P/N	Description	Comments Refer to B.1.02 	Disassembly Procedure
99	50512923 5K-2542-23	Rubber Grommet (in base)	RSPL	3.2.08 
101	50703701 4PP4043-2507P1	Collar: Eccentric (Carr. Rail) Head Adjustment	RSPL	3.2.18 
102	53478801 4PP4043-2460P1	Block: Release Lever Guide	RSPL	3.2.19 
109	N/A N/A	Rear Guide		3.2.19 
110	50082001 2YX4043-2570G1	Assembly: Paper Chute		3.2.19 
111	51005401 3PP4043-2548P1	Beam: Slide		N/A
112	51215601 4PP4043-2596G1	Pulley: Idle		3.2.15 
113	53327801 4PP4044-1282P1	Shaft: Idle Pulley		3.2.15 
114	51110301 4PP4043-2565P1	Shaft: Carriage		3.2.18 
115	50705701 4PB4043-2599P1	Ring: Cushion (Stopper)		3.2.18 
116	50213301 N/A	Frame: Base		3.2.08 
117	51605001 N/A	Bearing: Platen		3.2.09 
118	51007701 3PB4043-4357P1	Guide: Bottom (Mylar)		N/A
166	50705603 RE3-SK	Snap		3.2.09 
167	51605101 4PP4043-2455P1	Bushing		3.2.21
168	53529001	Lever: Near End (Bottom)		
169	54123804 2W4-HH	Washer		3.2.09 
181		Platen Lever		3.2.09 

182		Cartridge Bracket		3.2.11  B.2.13 
183		Pressure Bar		3.2.19 
184		Locking Shaft		3.2.21
185		Upper Drive Shaft		3.2.21
186		Lower Drive Shaft		3.2.21

Copyright 1997, Okidata, Division of OKI America, Inc. All rights reserved. See the OKIDATA Business Partner Exchange (BPX) for any updates to this material. (<http://bpx.okidata.com>)



Service Guide ML393/ML393CPlus



Chapter B Illustrated Parts Listing

B.2.09 Printer Mechanism - Color (1 of 3)

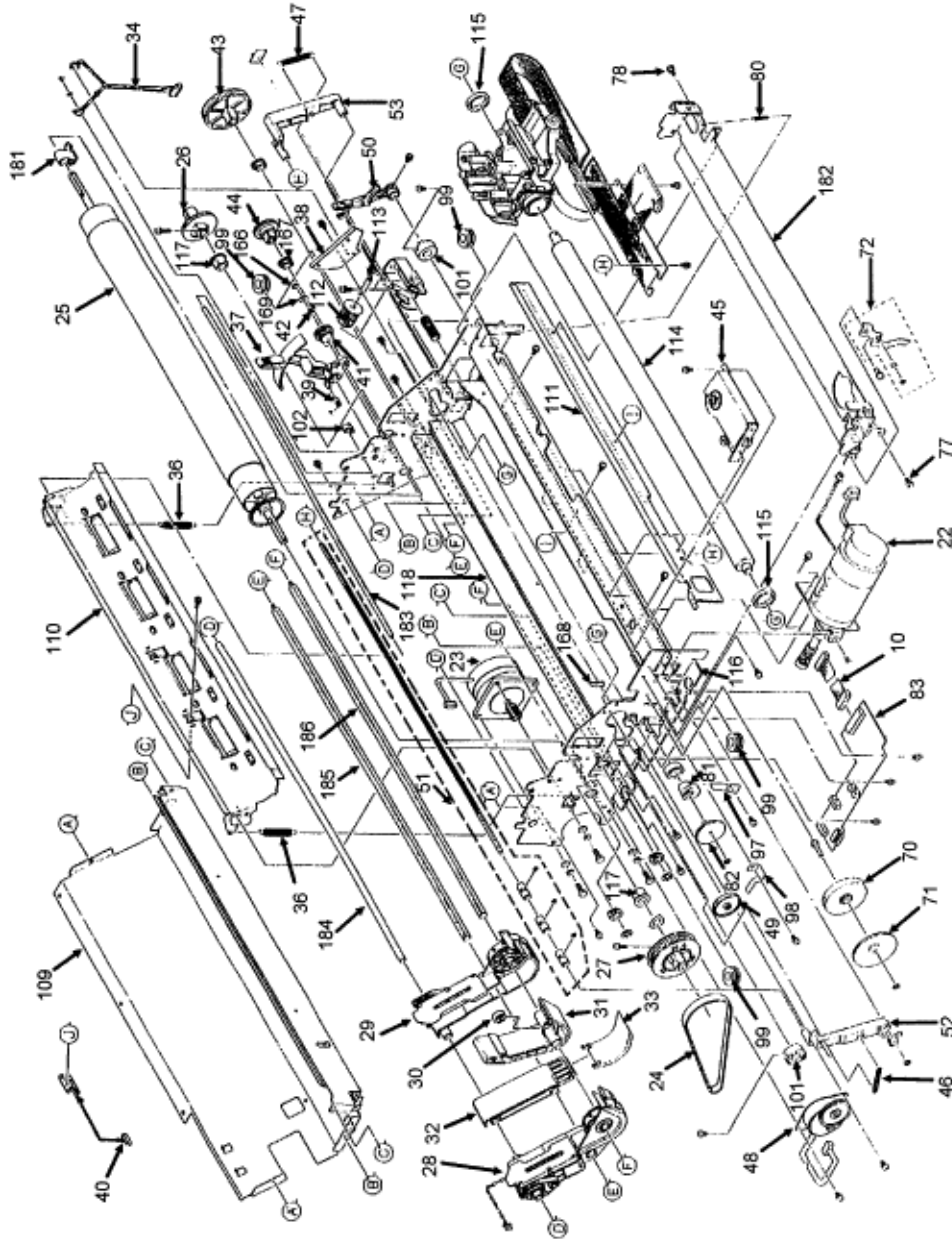
Part numbers are subject to change. Refer to Okilink II for current part numbers and pricing information.



Item	Okidata P/N Oki-J P/N	Description	Comments Refer to B.1.02 	Disassembly Procedure
10	56619101 4YS4011-4321P1	Cable: Sensor Board Connection	RSPL	3.2.12 
22	56506201 3YX4043-2550G1	Motor: Space Assembly	RSPL	3.2.14 
23	56508401 3PB4043-3853P1	Motor: Line Feed Assembly	RSPL	3.2.10 
24	51302790 4LP-1313-239	Belt: Mini Pitch (Line Feed)	RSPL	3.2.09 
25	50054101 4PA4043-2556G1	Platen: (Assembly)	RSPL	3.2.09 
26	51214501 3PP4043-2466P1	Gear: Platen - A	RSPL	3.2.09 
27	51215001 4PP4043-2465G1	Pulley: Platen	RSPL	3.2.09 
28	50054501 3YX4043-2561G1	Tractor: Push (Left) Assembly	RSPL	3.2.21 
29	50054601 3PA4043-2562G1	Tractor: Push (Right) Assembly	RSPL	3.2.21 
30	51002301 4PP4043-2451P1	Friction: Piece	RSPL	3.2.21 
31	51002401 3PP4043-2452P1	Guide: Center Upper	RSPL	3.2.21 
32	51002501 3PP4043-2453P1	Guide: Center Lower - A	RSPL	3.2.21 
33	51002601 3PP4043-2454P1	Guide: Center Lower - B	RSPL	3.2.21 
34	56209901 4YX4043-2784G1	Switch: Micro (Adj and Rel Lever)	RSPL	3.2.20 
36	50907502 4LB-193400-1	Spring: (Paper Chute)	RSPL	3.2.19 
37	53478706 3PP4043-2459P6	Lever: Release	RSPL	3.2.19 
38	53063801 3PP4043-4224P1	Bracket: PH Gap Indication		3.2.20 
39	50910201 4PB4043-2754P1	Spring: Detent (Release Lever)	RSPL	3.2.19 

40	55034801 4YX4043-2576G1	Sensor: Cut-Sheet Paper-End	RSPL	3.2.19 
41	51214401 4PP4043-2458P1	Gear: Idle (Release Lever)	RSPL	3.2.09 

Copyright 1997, Okidata, Division of OKI America, Inc. All rights reserved. See the OKIDATA Business Partner Exchange (BPX) for any updates to this material. (<http://bpx.okidata.com>)











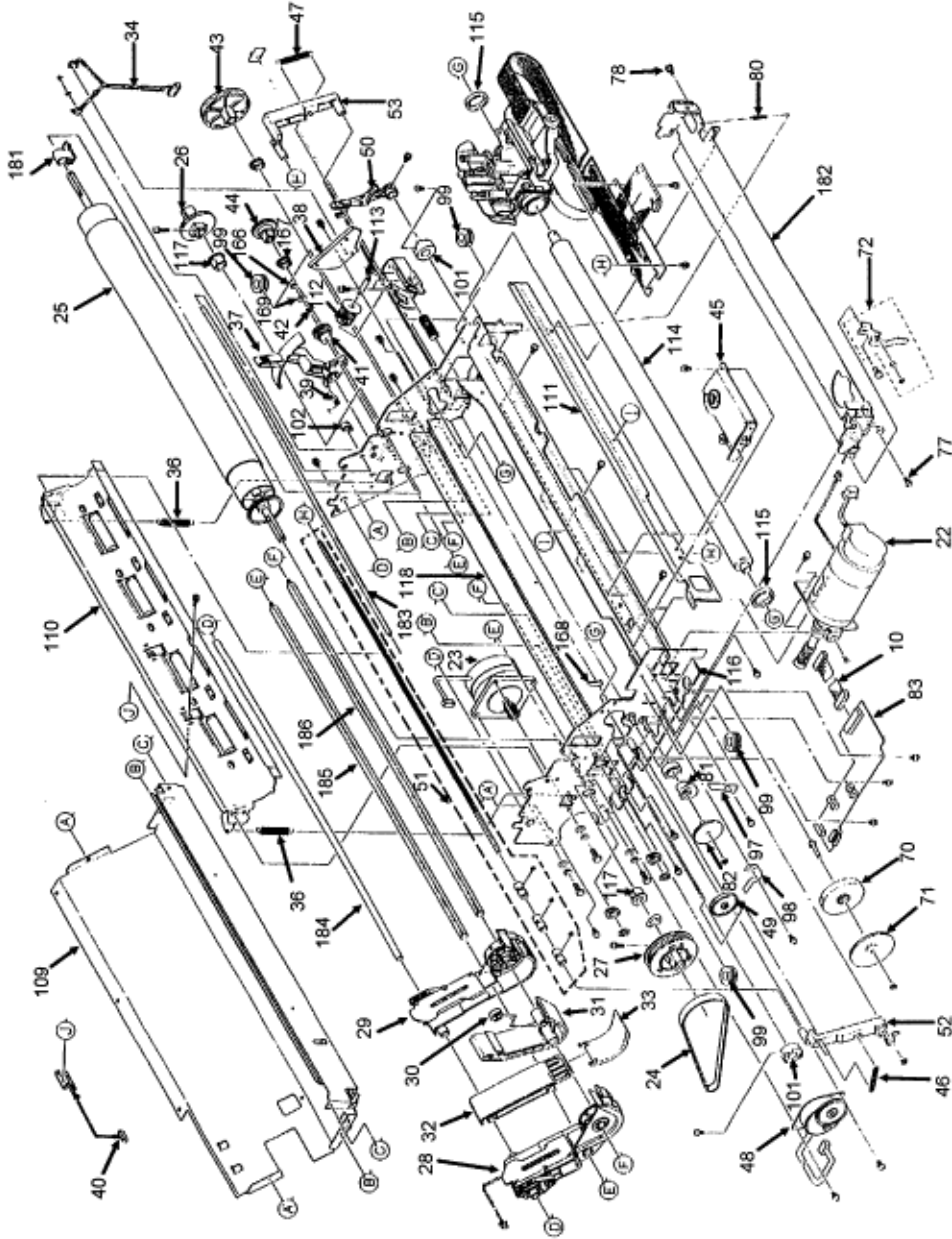













Service Guide ML393/ML393CPlus

Chapter B Illustrated Parts Listing

B.2.10 Printer Mechanism - Color (2 of 3)

Part numbers are subject to change. Refer to Okilink II for current part numbers and pricing information.



Item	Okidata P/N Oki-J P/N	Description	Comments Refer to B.1.02 	Disassembly Procedure
42	50910305 4LB-190600-6	Spring: Idle Gear	RSPL	3.2.09 
43	51214201 4PP4043-2456P1	Gear: Drive - A	RSPL	3.2.21 
44	51214301 4PP4043-2457P1	Gear: Drive - B	RSPL	3.2.21 
45	50054301 4PA4043-2584G1	Assembly: Ribbon Feed	RSPL	3.2.13 
46	50910701 4PP4043-2628P1	Spring: Bail Arm (Left)	RSPL	3.2.17 
47	50910801 4LB-193100-2	Spring: Bail Arm (Right)	RSPL	3.2.17 
48	56506301 3PP4043-2601P1	Motor: Step (Bail Arm) Assembly	RSPL	3.2.16 
49	51210201 5LR-193134-1	Gear: Idle (Bail Arm)	RSPL	3.2.17 
50	53478401 3PP4043-2504P1	Lever: Printhead Gap Adjust	RSPL	3.2.18 
51	50054401 4PA4043-2711G1	Assembly: Indicator Shaft	RSPL	3.2.17 
52	53478501 3PP4043-2509P1	Arm: Left Bail	RSPL	3.2.17 
53	53478502 3PP4043-2510P1	Arm: Right Bail	RSPL	3.2.17 
70	51222501 2PP4043-3325P1	Cam: Ribbon Shift (Color)	RSPL	3.2.27 
71	51215101 4PP4043-2729P1	Gear: Ribbon Shift (Color)	RSPL	3.2.27 
72	50054701 4PA4043-2710G1	Lever: Shift Cam (Color)	RSPL	3.2.28 
77	50312103 4LB-130100-3A	Screw: Shoulder Left (Color)	RSPL	3.2.11  , 3.2.13 
78	50312106 4LB-130100-6A	Screw: Shoulder Right (Color)	RSPL	3.2.11  , 3.2.13 
80	50910601 4PP4043-2642P1	Spring: Ribbon Cartridge Balance (Color)	RSPL	3.2.11  , 3.2.13 

81	51222601 3PP4043-3321P1	Cam: Bail Open (Color)	RSPL	3.2.26 
82	51214601 4PP4043-2499P1	Gear: Bail Open (Color)	RSPL	3.2.26 
83	55050502 4YA4042-1462G2	PCB: Sensor (LQEW-2) (Color)	RSPL	3.2.12 
97	50910901 4PB4043-3240P1	Spring: Brake - A	RSPL	3.2.27 
98	50911001 4PP4043-2783P1	Spring: Brake - B (Color)	RSPL	3.2.26 

Copyright 1997, Okidata, Division of OKI America, Inc. All rights reserved. See the OKIDATA Business Partner Exchange (BPX) for any updates to this material. (<http://bpx.okidata.com>)



Service Guide ML393/ML393CPlus





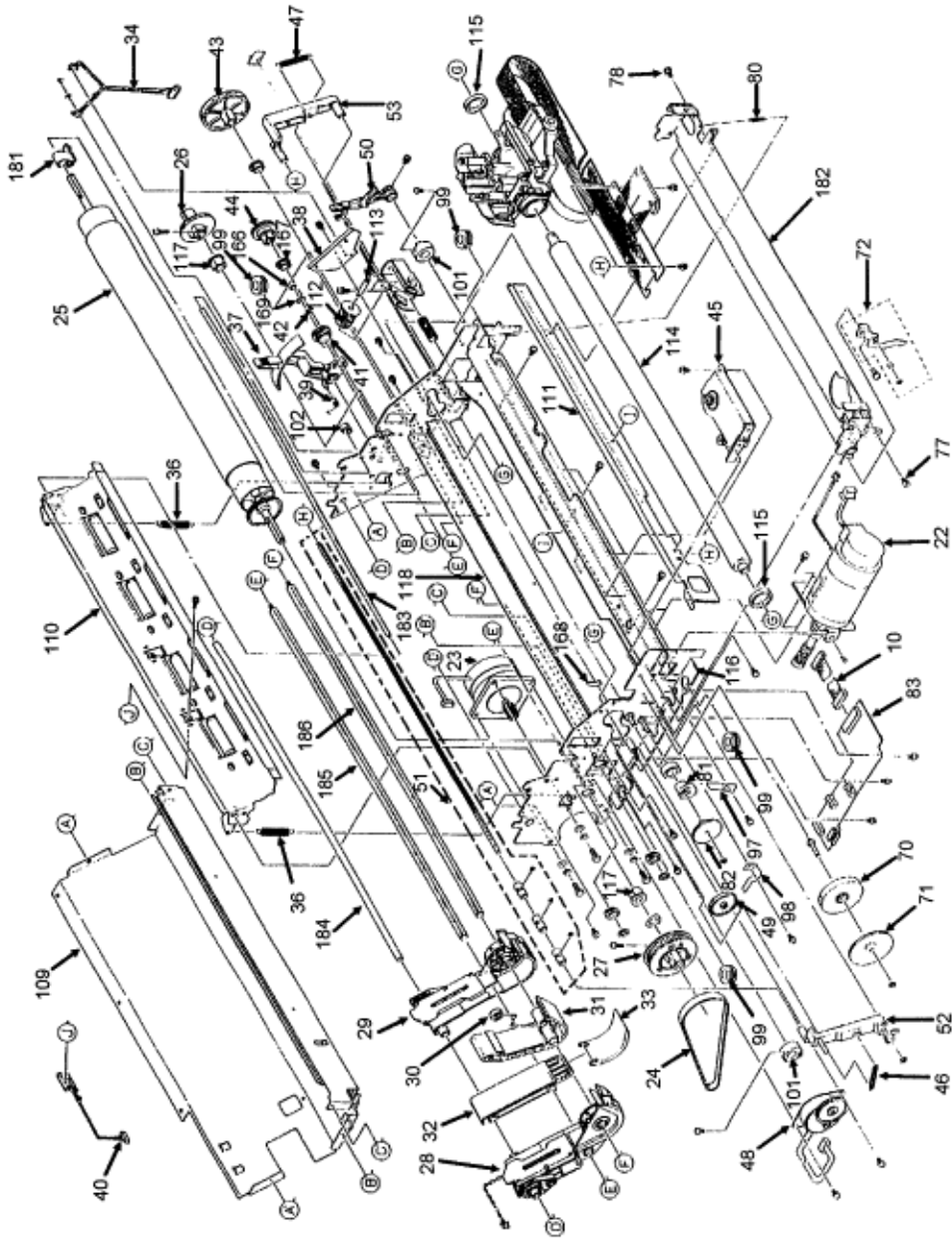

Chapter B Illustrated Parts Listing

B.2.11 Printer Mechanism - Color (3 of 3)

Part numbers are subject to change. Refer to Okilink II for current part numbers and pricing information.



Item	Okidata P/N Oki-J P/N	Description	Comments Refer to B.1.02 	Disassembly Procedure
99	50512923 5K-2542-23	Rubber Grommet (in base)	RSPL	3.2.08 
101	50703701 4PP4043-2507P1	Collar: Eccentric (Carr. Rail) Head Adjustment	RSPL	3.2.18 
102	53478801 4PP4043-2460P1	Block: Release Lever Guide	RSPL	3.2.19 
109	N/A N/A	Rear Guide		3.2.19 
110	50082001 2YX4043-2570G1	Assembly: Paper Chute		3.2.19 
111	51005401 3PP4043-2548P1	Beam: Slide		N/A
112	51215601 4PP4043-2596G1	Pulley: Idle		3.2.15 
113	53327801 4PP4044-1282P1	Shaft: Idle Pulley		3.2.15 
114	51110301 4PP4043-2565P1	Shaft: Carriage		3.2.18 
115	50705701 4PB4043-2599P1	Ring: Cushion (Stopper)		3.2.18 
116	50213301 N/A	Frame: Base		3.2.08 
117	51605001 N/A	Bearing: Platen		3.2.09 
118	51007701 3PB4043-4357P1	Guide: Bottom (Mylar)		N/A
166	50705603 RE3-SK	Snap		3.2.09 
167	51605101 4PP4043-2455P1	Bushing		3.2.21 
168	53529001	Lever: Near End (Bottom)		
169	54123804 2W4-HH	Washer		3.2.09 
		Platen Lever		3.2.09 

		Cartridge Bracket		3.2.11  3.2.13 
		Pressure Bar		3.2.19 
		Locking Shaft		3.2.21 
		Upper Drive Shaft		3.2.21 
		Lower Drive Shaft		3.2.21 

Copyright 1997, Okidata, Division of OKI America, Inc. All rights reserved. See the OKIDATA Business Partner Exchange (BPX) for any updates to this material. (<http://bpx.okidata.com>)

B.2.12 Carriage Assembly - Monochrome

Part numbers are subject to change. Refer to Okilink II for current part numbers and pricing information.

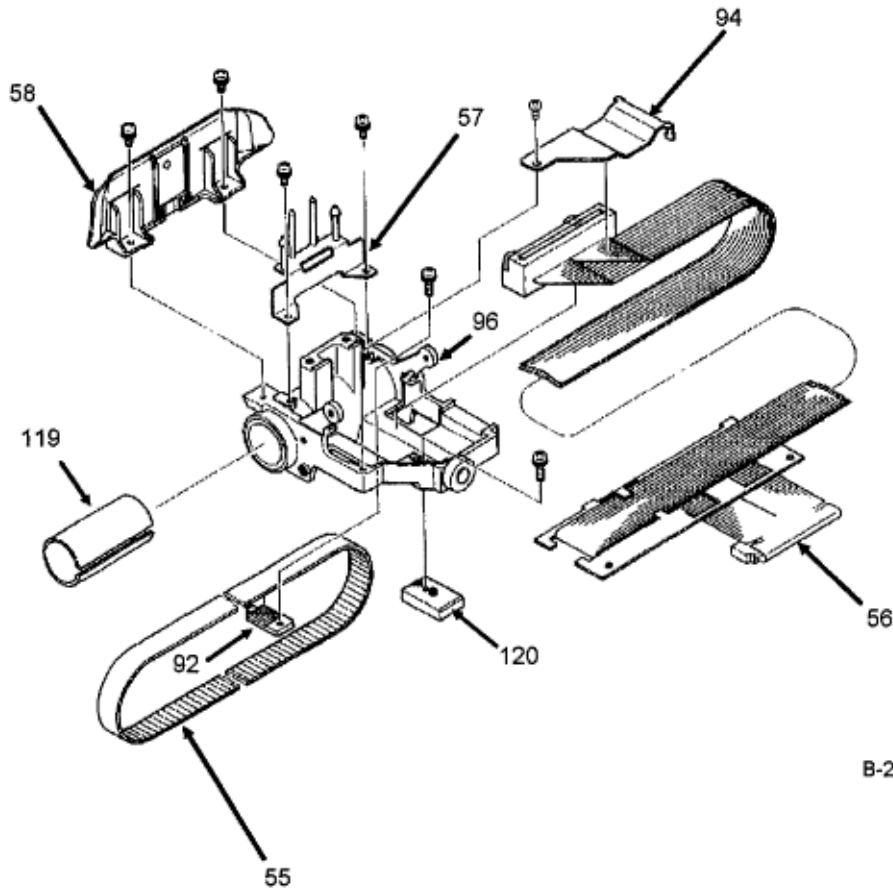

B-2-1

Item	Okidata P/N Oki-J P/N	Description	Comments Refer to B.1.02	Disassembly Procedure
55	51303101 4PB4044-1492P3	Belt: Mini Pitch (Space)	RSPL	3.2.15
56	56614201 3YX4043-2713G1	Cable: Printhead Assembly	RSPL	3.2.11
57	53055901 4PP4043-2643G1	Guide: Ribbon (Black)	RSPL	3.2.02

58	53527001 4PP4043-3954G1	Protector: Ribbon	RSPL	3.2.03 
92	50702301 LR-193368-1	Clamp: Belt	RSPL	3.2.15 
94	N/A N/A	Clamp		3.2.11 
96	50057601 2YX4043-2610G3	Carriage: Black Assembly	RSPL	3.2.18 
119	N/A N/A	Spacer: Round		3.2.18 
120	51005501 4PP4044-1340P1	Guide: Slide		3.2.18 

Copyright 1997, Okidata, Division of OKI America, Inc. All rights reserved. See the OKIDATA Business Partner Exchange (BPX) for any updates to this material. (<http://bpx.okidata.com>)

B.2.13 Carriage Assembly - Color

Part numbers are subject to change. Refer to Okilink II for current part numbers and pricing information.

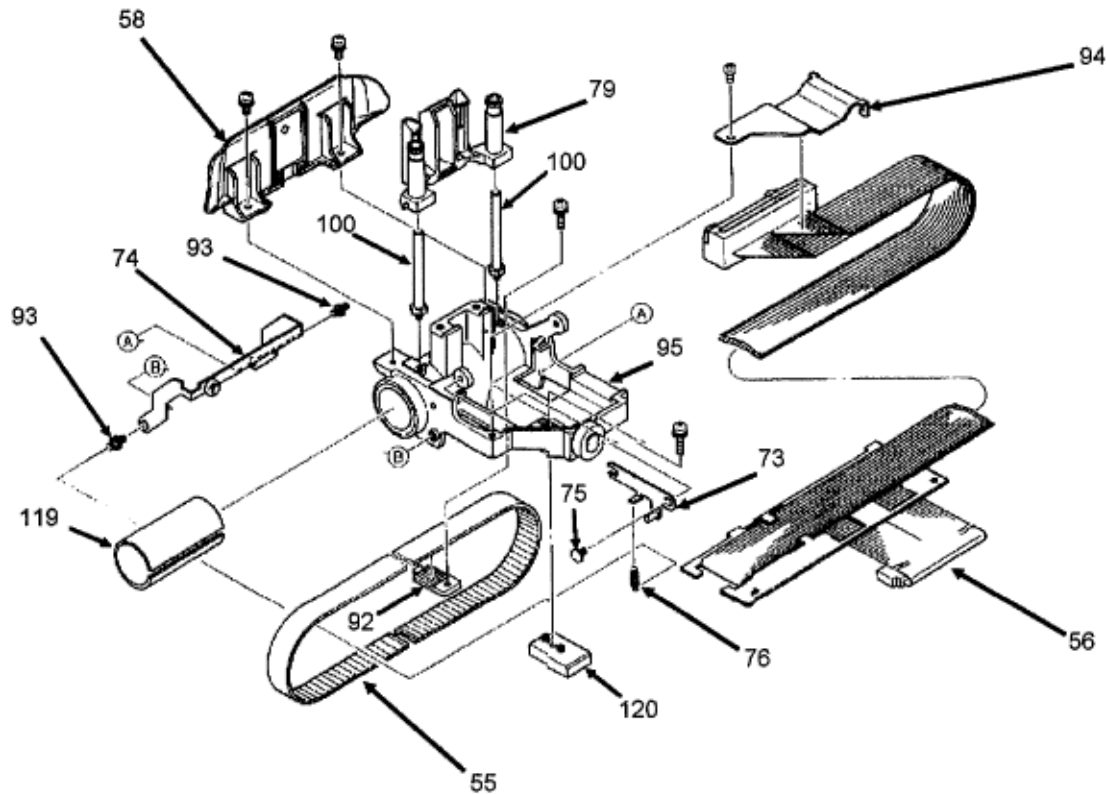

Item	Okidata P/N Oki-J P/N	Description	Comments Refer to B.1.02	Disassembly Procedure
55	51303101 4PB4044-1492P3	Belt: Mini Pitch (Space)	RSPL	3.2.15
56	56614201 3YX4043-2713G1	Cable: Printhead Assembly	RSPL	3.2.11
58	53527001 4PP4043-3954G1	Protector: Ribbon	RSPL	3.2.03
73	53478901 4PP4043-2776G1	Arm: Ribbon Shift (Color)	RSPL	3.2.23

74	53479001 4PP4043-2741G1	Lever: Roller (Color)	RSPL	3.2.24 
75	50315401 4PP4043-2745P1	Screw (Color)	RSPL	3.2.23 
76	50917811 4LB-192400-11	Spring: Ribbon Shift Arm (Color)	RSPL	3.2.23 
79	53056002 3PP4043-2477P2	Guide: Ribbon (Color)	RSPL	3.2.25 
92	50702301 LR-193368-1	Clamp: Belt	RSPL	3.2.15 
93	N/A N/A	Screw		3.2.24 
94	N/A N/A	Clamp		3.2.11 
95	50069401 2YX4043-2719G3	Carriage: Color Assembly	RSPL	3.2.18 
100	50605701 4PP4043-2615P1	Post: Ribbon Guide (Color)	RSPL	3.2.25 
119	N/A N/A	Spacer: Round		3.2.18 
120	51005501 4PP4044-1340P1	Guide: Slide		3.2.18 

Copyright 1997, Okidata, Division of OKI America, Inc. All rights reserved. See the OKIDATA Business Partner Exchange (BPX) for any updates to this material. (<http://bpx.okidata.com>)



Service Guide ML393/ML393CPlus

Chapter B Illustrated Parts Listing

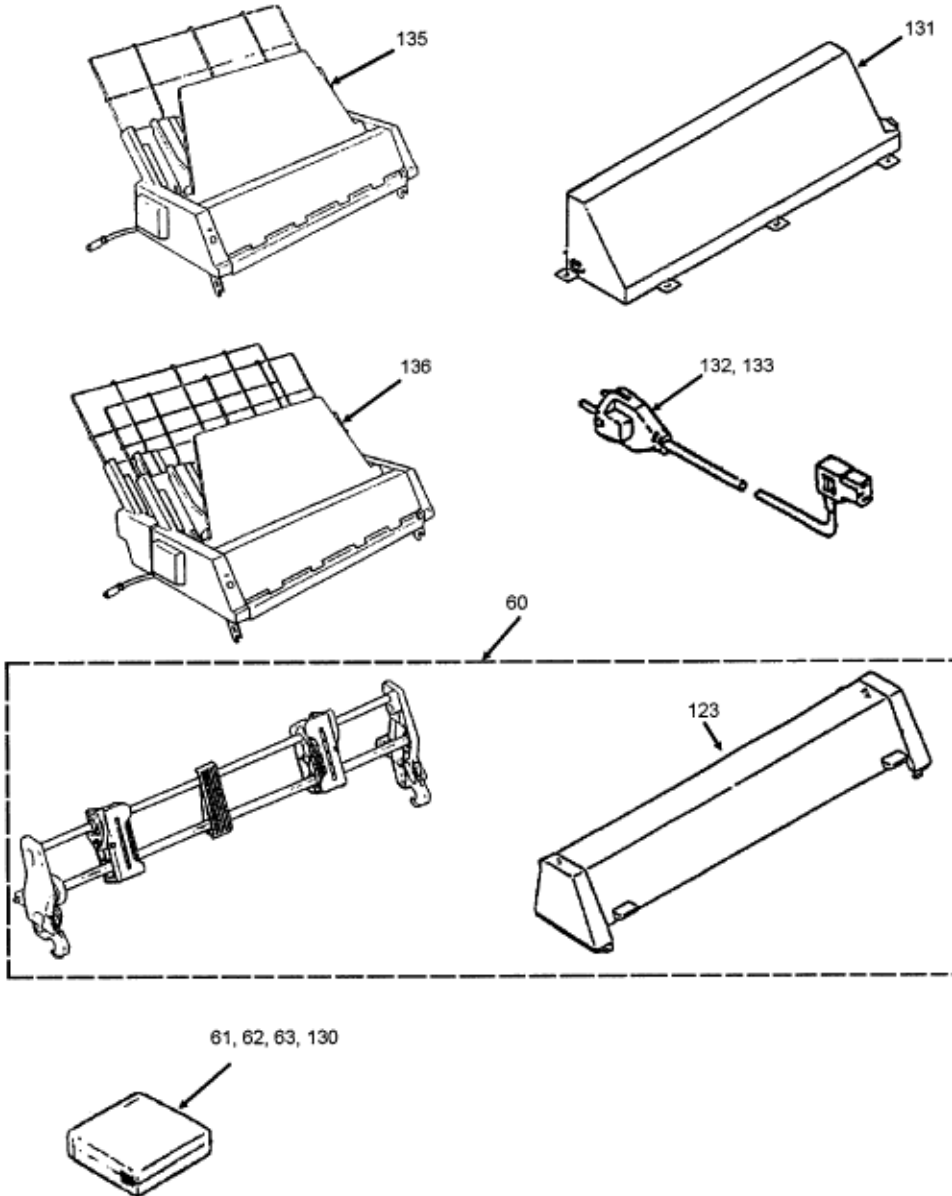

B.2.14 Options

Part numbers are subject to change. Refer to Okilink II for current part numbers and pricing information.



Not Shown:
121, 122, 124, 134, and 137

Item	Okidata P/N Oki-J P/N	Description	Comments Refer to B.1.02 	Disassembly Procedure
60	70011701 2PA4016-4722G4	Pull Tractor Assembly w/ Acoustic Cover	Option	N/A
61	70010201 4YA4042-1301G101	Gothic Font Cartridge	Option	3.2.04 
62	70010101 4YA4042-1301G102	Prestige Font Cartridge	Option	3.2.04 
63	70016401 4YA4042-1470G101	Cartridge: 32 Kbyte RAM Expansion	Option	3.2.04 
121	70014901 N/A	Windows Driver Software	Option 393	N/A
122	70012201 N/A	Microline Control Emulation Software	Option 393	N/A
123	50212601 3PA4016-4722G1	Cover: Acoustic (Pull Tractor)	Option	N/A
123	50212604 2PA4016-4722G4	Cover: Acoustic (Pull Tractor)	Option RSPL	N/A
124	53480901 N/A	Cut Sheet Feeder Output Tray	Option	N/A
130	55033301 4YA4042-1301G101	Font Cart: Gothic (393)	Option	N/A
130	55033401 4YA4042-1301G102	Font Cart: Prestige (393)	Option	N/A
131	56406301 4YB4049-1278P1	Power Supply (220 v)	Option	3.2.22 
132	56610801 3YS4011-1052P1	Cord: Line 220 V (393)	Option	N/A
133	56616501 3YS4011-1192P1	Cord: AC 240 V (393)	Option	N/A
134	70000803 N/A	Kit: Parallel Interface Plug'n'Play Accessory	Option Both	3.2.01  , 3.2.04 
135	70010601 N/A	Cut Sheet Feeder 30001 Single Bin	Option	3.2.29 
136	70010701 N/A	Cut Sheet Feeder 30002 Dual Bin	Option	3.2.29 

137	70012801 N/A	Kit: RS232-C Serial Interface	Option Both	3.2.01  3.2.04 
-----	-----------------	----------------------------------	-------------	--

Copyright 1997, Okidata, Division of OKI America, Inc. All rights reserved. See the OKIDATA Business Partner Exchange (BPX) for any updates to this material. (<http://bpx.okidata.com>)

B.2.15 Pull Tractor Assembly (Option)

Part numbers are subject to change. Refer to Okilink II for current part numbers and pricing information.

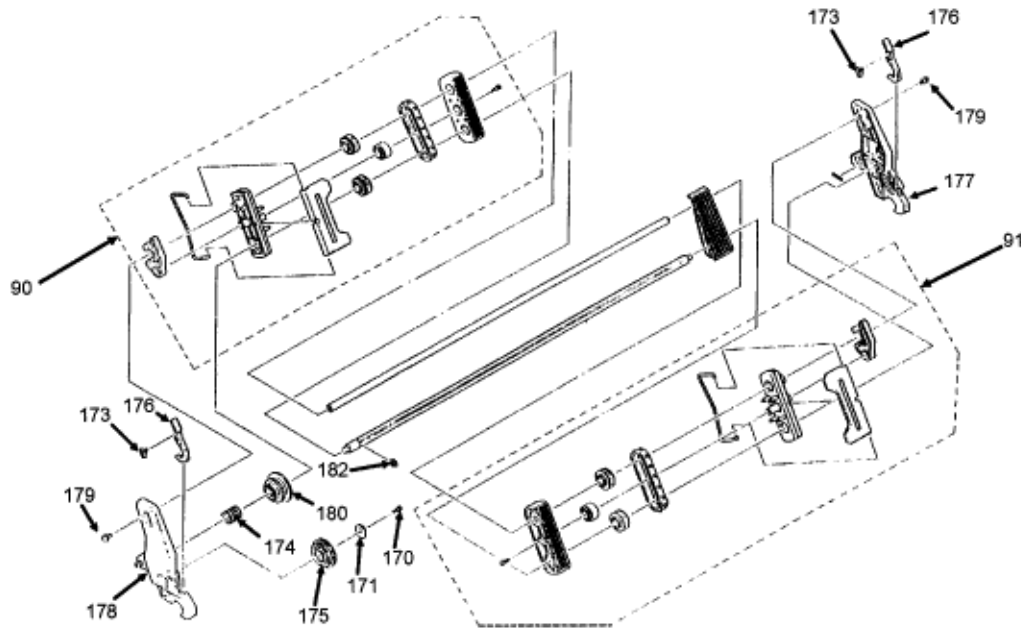

Item	Okidata P/N Oki-J P/N	Description	Comments Refer to B.1.02	Disassembly Procedure
90	50057401 4PA4043-2684G1	Tractor: Pin (Left) Pull Tractor Assembly	Option	N/A
91	50057501 4PA4043-2685G1	Tractor: Pin (Right) Pull Tractor Assembly	Option	N/A
170	50315501 +T2P3-8-HHC-V	Screw: Tapping		N/A
171	50514501 4PP4043-2688P1	Washer		N/A
172	50705605 RE5-SK	Snap		N/A

173	50918801 4PP4025-1341	Spring: Reset		N/A
174	50918901 4PB4043-2691P1	Spring		N/A
175	51223401 4PP4043-2690P1	Gear: Idle		N/A
176	53535401 4PP4043-2696P1	Lever: Lock		N/A
177	53535501 2PP4043-2687P1	Frame: Side (Right)		N/A
178	53535601 2PP4043-2686P1	Frame: Side (Left)		N/A
179	54123306 +P(SW+W)3-6-23D	Screw		N/A
180	51223501 4PP4043-2689P1	Gear: Drive		N/A

Copyright 1997, Okidata, Division of OKI America, Inc. All rights reserved. See the OKIDATA Business Partner Exchange (BPX) for any updates to this material. (<http://bpx.okidata.com>)



B.2.16 Packing Materials

Part numbers are subject to change. Refer to Okilink II for current part numbers and pricing information.

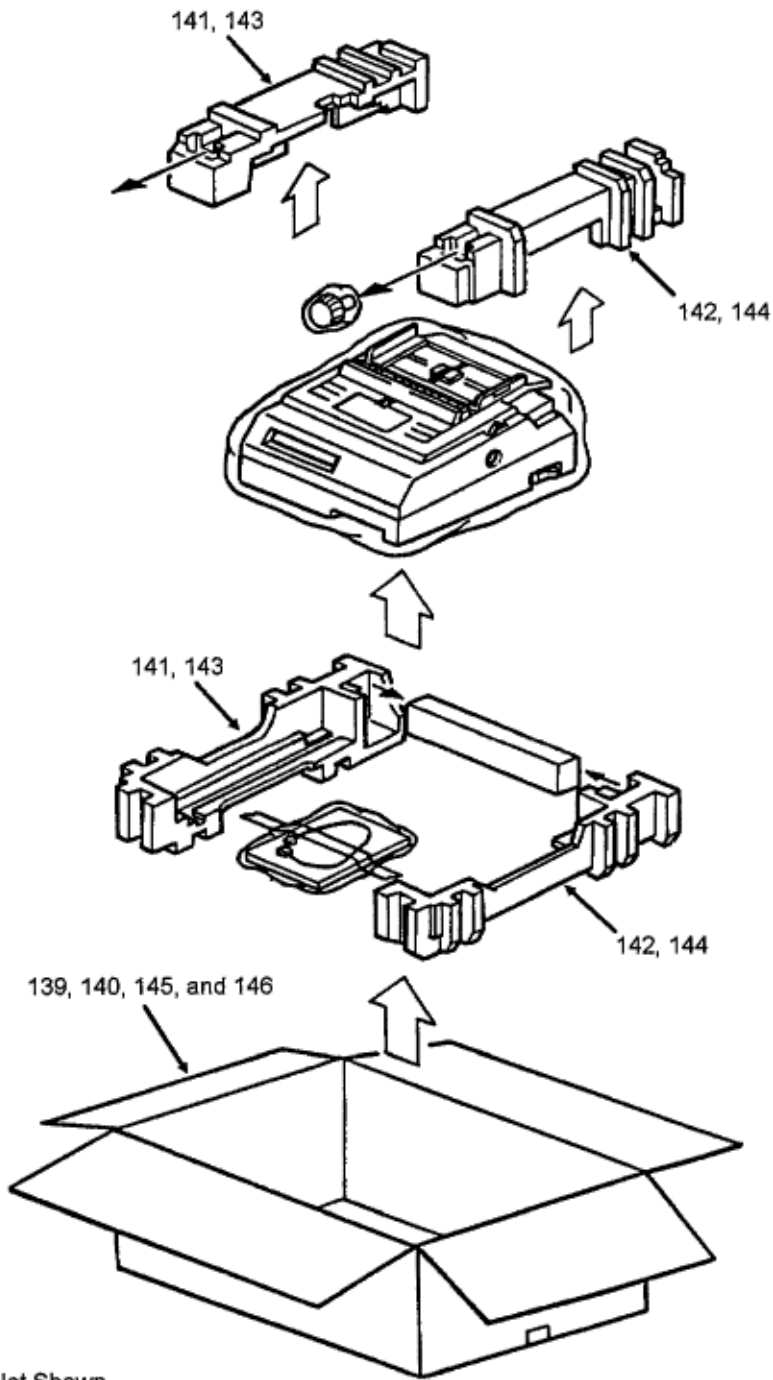

Not Shown
138 and 147

Item	Okidata P/N Oki-J P/N	Description	Comments Refer to B.1.02 📄	Disassembly Procedure
138	53460209	Overpack ML393+		N/A
139	53477201	Box: ML393 Epson		N/A

140	53477202	Box: ML393 Epson / IBM		N/A
141	53481001	End Cap (Left) ML393		N/A
142	53481001	End Cap (Right) ML393		N/A
143	53528901	End Cap (Left) ML393+		N/A
144	53528902	End Cap (Right) ML393+		N/A
145	53532001	Box: ML393+		N/A
146	53532101	Box: ML393+ Color		N/A
147	53532501	Foam Spacer ML393+		N/A

Copyright 1997, Okidata, Division of OKI America, Inc. All rights reserved. See the OKIDATA Business Partner Exchange (BPX) for any updates to this material. (<http://bpx.okidata.com>)



Service Guide ML393/ML393CPlus

Chapter B Illustrated Parts Listing

B.2.17 Consumables

Part numbers are subject to change. Refer to Okilink II for current part numbers and pricing information.

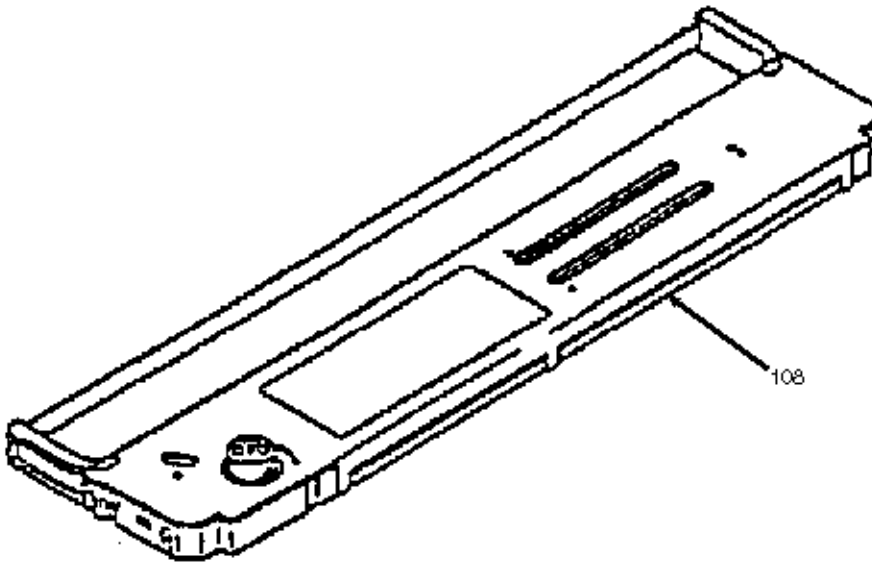

Item	Okidata P/N Oki-J P/N	Description	Comments Refer to B.1.02	Disassembly Procedure
108	52103601 N/A	Cartridge: Ribbon (Black)	Consumable	3.2.01
108	52103701 N/A	Cartridge: Ribbon (Color)	Consumable	3.2.01
108	52103801 N/A	Cartridge: Film Ribbon (Black)	Consumable	3.2.01



Service Guide ML393/ML393CPlus

Chapter B Illustrated Parts Listing

B.2.18 Documentation

Part numbers are subject to change. Refer to Okilink II for current part numbers and pricing information.

Item	Okidata P/N Oki-J P/N	Description	Comments Refer to B.1.02 	Disassembly Procedure
1 A #	58214701D N/A	Kit: Service Training Microline 393	Document Includes 1 - 7 A	N/A
1 B #	58218601 N/A	Kit: Microline 393-Plus/393C-Plus Service Training	Document Includes 2 - 14 B	N/A
1 C #	58218602 N/A	Kit: Microline 393-Plus/393C-Plus Service Training	Document Includes 2 - 7 C	N/A
188	58057001 N/A	Guide: Customer Service Microline 393/393C-Plus	Document	N/A
189	59227204 N/A	Manual: Maintenance Microline 393	Document	N/A
190	59227303 N/A	Manual: Troubleshooting Microline 393	Document	N/A
191	59227401 N/A	Manual: Maintenance Cut-Sheet Feeder 3001/3002	Document	N/A
191	59227402 N/A	Manual: Maintenance Cut-Sheet Feeder 3001/3002	Document	N/A
192	59240301 N/A	Product Specifications Microline 393/393C-Plus	Document	N/A

193	59240901 N/A	Guide: Setup Microline 393/393C-Plus	Document	N/A
193	59240902 N/A	Guide: Setup Microline 393/393C-Plus	Document	N/A
194	59241001 N/A	Guide: Reference Microline 393/393C-Plus	Document	N/A
194	59241002 N/A	Guide: Reference Microline 393/393C-Plus	Document	N/A
195	59241301 M-520780 Issue 1B	Manual: Maintenance Microline 393/393C-Plus	Document	N/A
196	59241401 N/A	Manual: Troubleshooting Microline 393/393C-Plus	Document	N/A

* To order Marketing Literature, complete an Okidata Marketing Literature Order Form. Fax the completed form to Okidata Marketing Communications.

** Obtain this form by faxing a request to Okidata Marketing Communications. Refer to the Service Center Reference Guide for information on contacting Okidata.

Refer to Section B.2.19 of this Service Handbook.

Item	Okidata P/N Oki-J P/N	Description	Comments Refer to B.1.02 📄	Disassembly Procedure
197	58067201 N/A	ABCD Warranty Claim Forms (Pkg of 20)	Document Both	N/A
198 *	N/A N/A	Marketing Literature	Document Both	N/A
199 **	N/A N/A	Okidata Marketing Literature Order Form	Document Both	N/A
200	N/A N/A	Okidata Service Center Reference Guide	Document Both	N/A
201	53547501 N/A	Okidata Support 3-Ring Binder	Document Both	N/A

202	N/A N/A	Printer Drivers	Refer to Okilink	N/A
203	N/A N/A	Product Updates	Document Refer to Okilink	N/A
204	N/A N/A	Recommended Spare Parts List	Document Refer to Okilink	N/A
205	N/A N/A	Software	Refer to Okilink	N/A
206	N/A N/A	Technical Service Bulletins	Document Refer to Okilink	N/A
207	58052401 N/A	Warranty Summary Forms (Pkg of 20)	Document Both	N/A

* To order Marketing Literature, complete an Okidata Marketing Literature Order Form. Fax the completed form to Okidata Marketing Communications.

* * Obtain this form by faxing a request to Okidata Marketing Communications. Refer to the Service Center Reference Guide for information on contacting Okidata.

Refer to Section B.2.19 of this Service Handbook. 

Copyright 1997, Okidata, Division of OKI America, Inc. All rights reserved. See the OKIDATA Business Partner Exchange (BPX) for any updates to this material. (<http://bpx.okidata.com>)



Service Guide ML393/ML393CPlus

Chapter B Illustrated Parts Listing

B.2.19 Service Training Kit Revision List

P/N 58218601 Microline 393-Plus / 393C-Plus Service Training Kit

This kit was replaced by P/N 58218602.

Except for the Customer Service, Reference, and Setup Guides and the Cut Sheet Feeder Maintenance Manual, items in the training kit are NOT available separately.

Item	Okidata P/N Oki-J P/N	Description	Comments Refer to B.1.02 	Disassembly Procedure
1 B	58218601 N/A	Kit: Microline 393-Plus/393C-Plus Service Training	Document Includes 2 - 14 B	N/A
2 B	52043101 N/A	Label: Kit	Document Part of 1 B	N/A
3 B	58057901 N/A	Letter: Cover	Document Part of 1 B	N/A
4 B	59241701 N/A	Guide: Study	Document Part of 1 B	N/A
5 B	59241601 N/A	Manual: Training	Document Part of 1 B	N/A
6 B	58057001 N/A	Guide: Customer Service	Document Part of 1 B	N/A
7 B	59251001 N/A	Guide: Microline 393/393C-Plus Reference	Document Part of 1 B	N/A
8 B	59240901 N/A	Guide: Microline 393/393C-Plus Setup	Document Part of 1 B	N/A
9 B	59227402 N/A	Manual: Maintenance Cut-Sheet Feeder 3001/3002	Document Part of 1 B	N/A
10 B	57516401 N/A	Video: Service Training	Document Part of 1 B	N/A
11 B	52043102 N/A	Label: Videotape Case	Document Part of 1 B	N/A

12 B	52043102 N/A	Label: Videotape Front	Document Part of 1 B	N/A
13 B	53533001 N/A	Storage Box	Document Part of 1 B	N/A
14 B	57517101 N/A	Red Vinyl Case (VHS) Video	Document Part of 1 B	N/A

P/N 58218602 Microline 393-Plus / 393C-Plus Service Training Kit

This kit replaces P/N 58218601.

Except for the Reference and Setup Guides, items in the training kit are NOT available separately.

Item	Okidata P/N Oki-J P/N	Description	Comments Refer to B.1.02 	Disassembly Procedure
1 C	58218602 N/A	Kit: Microline 393-Plus/393C-Plus Service Training	Document Includes 2 - 7 C	N/A
2 C	52043103 N/A	Label: Kit	Document Part of 1 C	N/A
3 C	58057902 N/A	Read Me First	Document Part of 1 C	N/A
4 C	59241602 N/A	Handbook: Service	Document Part of 1 C	N/A
5 C	59251002 N/A	Guide: Microline 393/393C-Plus Reference	Document Part of 1 B	N/A
6 C	59240902 N/A	Guide: Microline 393/393C-Plus Setup	Document Part of 1 B	N/A
7 C	57516402 N/A	Video: Service Training	Document Part of 1 C	N/A
8 C	52043104 N/A	Label: Videotape Spine	Document Part of 1 C	N/A
9 C	53570401 N/A	Sleeve: Videotape (Cardboard)	Document Part of 1 C	N/A

P/N 58215601 Microline 300 Series Service Training Kit

This kit was replaced by P/N 58215602.

This kit covered the printers listed below. Each printer had its own training package within the Microline 300 Series Training Kit, P/N 58215601.

Microline 320/321 P/N 58215501B

Microline 390/391 P/N 59230701B

Microline 393 P/N 58214701D

Except for the Customer Service, Reference, and Setup Guides and the Cut Sheet Feeder Maintenance Manual, items in the training kit are NOT available separately.

Item	Okidata P/N Oki-J P/N	Description	Comments Refer to B.1.02 📄	Disassembly Procedure
1 X	58215601 N/A	Kit: Service Training Microline 300 Series	Document Includes 1 Y Z A	N/A
1 Y	58215501B N/A	Kit: Service Training Microline 320/321	Document Includes 2 - 7 Y	N/A
1 Z	59230701B N/A	Kit: Service Training Microline 390/391	Document Includes 2 - 8 Z	N/A
1 A	58214701D N/A	Kit: Service Training Microline 393	Document Includes 2-8 A	N/A

P/N 58215501B Microline 320/321 Service Training Kit

This kit was replaced by P/N 58215502.

This kit was part of the Microline 300 Series Training Kit, P/N 58215601.

Item	Okidata P/N Oki-J P/N	Description	Comments Refer to B.1.02 📄	Disassembly Procedure
1 Y	58215501B N/A	Kit: Service Training Microline 320/321	Document Includes 2 - 7 Y	N/A
2 Y	58046101 N/A	Cover Letter: Microline 320/321	Document Part of 1 Y	N/A
3 Y	58045301 N/A	Guide: Customer Service Microline 320/321	Document Part of 1 Y	N/A
4 Y	59231501 N/A	Manual: Training Microline 320/321	Document Part of 1 Y	N/A
5 Y	59231601 N/A	Guide: Self-Study Microline 320/321	Document Part of 1 Y	N/A
6 Y	59230801 N/A	Guide: Setup Microline 320/321	Document Part of 1 Y	N/A
7 Y	59231401 N/A	Guide: Reference Microline 320/321	Document Part of 1 Y	N/A

P/N 59230701B Microline 390/391 Service Training Kit

This kit was replaced by P/N 59230702.

Item	Okidata P/N Oki-J P/N	Description	Comments Refer to B.1.02 	Disassembly Procedure
1 Z	59230701B N/A	Kit: Service Training Microline 390/391	Document Includes 2 - 8 Z	N/A
2 Z	58045401 N/A	Cover Letter: Microline 390/391	Document Part of 1 Z	N/A
3 Z	59230501 N/A	Guide: Self-Study Microline 390/391	Document Part of 1 Z	N/A
4 Z	58044501 N/A	Guide: Customer Service Microline 390/391	Document Part of 1 Z	N/A
5 Z	59230202 N/A	Guide: Setup Microline 390/391	Document Part of 1 Z	N/A
6 Z	59230301 N/A	Guide: Reference Microline 390/391	Document Part of 1 Z	N/A
7 Z	59230601 N/A	Manual: Training Microline 390/391	Document Part of 1 Z	N/A
8 Z	59231001 M-520656 Issue 1A	Manual: Maintenance Cut-Sheet Feeder 3000	Document Part of 1 Z	N/A

P/N 58214701D Microline 393 Service Training Kit

This kit was replaced by P/N 58218601.

Item	Okidata P/N Oki-J P/N	Description	Comments Refer to B.1.02 	Disassembly Procedure
1 A	58214701D N/A	Kit: Service Training Microline 393	Document Includes 2-8 A	N/A
2 A	58042103 N/A	Cover Letter Microline 393	Document Part of 1 A	N/A
3 A	58041703 N/A	Guide: Customer Service Microline 393	Document Part of 1 A	N/A
4 A	59227003 N/A	Guide: Setup Microline 393	Document Part of 1 A	N/A

5 A	59232601 N/A	Guide: Reference Epson/IBM Compatible Microline 393	Document Part of 1 A	N/A
6 A	59229001 N/A	Guide: Self-Study Microline 393	Document Part of 1 A	N/A
7 A	59228001 N/A	Package: Training Microline 393	Document Part of 1 A	N/A
8 A	59227402 M-520565 2D	Manual: Maintenance Cut-Sheet Feeder 3001/3002	Document Part of 1 A	N/A

Copyright 1997, Okidata, Division of OKI America, Inc. All rights reserved. See the OKIDATA Business Partner Exchange (BPX) for any updates to this material. (<http://bpx.okidata.com>)



Service Guide ML393/ML393CPlus

Chapter C Microline 393/393C Specifications

C.1 OVERVIEW

C.1.01 General Information

This appendix covers the specifications for the Microline 393 and Microline 393C printers. This information is provided for those technicians who work with these models.

The Microline 393 and Microline 393C are high speed, dot matrix printers, which utilize a 24-pin printhead.

The Microline 393 is a standard version, single color output.

The Microline 393C is a color capable version.

The printers are capable of emulating the Epson LQ-2550 or the IBM XL24 printers.

Both an RS232-C Serial Interface and a Centronics Parallel Interface are standard.

Copyright 1997, Okidata, Division of OKI America, Inc. All rights reserved. See the OKIDATA Business Partner Exchange (BPX) for any updates to this material. (<http://bpx.okidata.com>)



Service Guide ML393/ML393CPlus

Chapter C Microline 393/393C Specifications

C.2 PRINTER SPECIFICATIONS

C.2.01 Interface Methods

Both are available

Centronics Parallel Interface

RS232-C Serial Interface

C.2.02 Line Feed Increments

1/6"

1/8"

n/60"

n/180"

n/360"

C.2.03 Line Feed Time

55 ms @ 6 LPI

8.0 IPS (inches per second) slew rate @ gap 1,2

6.0 IPS (inches per second) slew rate @ gap 3+

C.2.04 Paper Feed Method

Built-in push tractor

Friction feed

C.2.05 Paper Out Detection

Distance from end of paper

Rear Feed: 2.3"

Bottom Feed: .94"

Cut Sheet: .93"

C.2.06 Paper Path

Bottom Feed

Rear Feed

Top Feed

C.2.07 Printhead Type

Staggered, 24 pin, stored energy printhead

C.2.08 Standard Fonts

Utility (Used in Utility and High Speed Draft Modes)

Courier

Helvetica

Roman

Orator

C.2.09 Symbol Sets

Standard ASCII

Epson Character Set

IBM Character Set I and Set II

IBM Proprinter All Character Set

International Characters

Line Graphics

Copyright 1997, Okidata, Division of OKI America, Inc. All rights reserved. See the OKIDATA Business Partner Exchange (BPX) for any updates to this material. (<http://bpx.okidata.com>)



Service Guide ML393/ML393CPlus

Chapter C Microline 393/393C Specifications

C.3 PAPER SPECIFICATIONS

C.3.01 Types

Letter

Legal

Labels - *Bottom feed only*

Continuous Forms

C.3.02 Weight

12 - 24 lb.

16 - 24 lbs (Cut Sheet Feeders)

C.3.03 Number of Copies

1-4

Copyright 1997, Okidata, Division of OKI America, Inc. All rights reserved. See the OKIDATA Business Partner Exchange (BPX) for any updates to this material. (<http://bpx.okidata.com>)



Service Guide ML393/ML393CPlus

Chapter C Microline 393/393C Specifications

C.4 PHYSICAL SPECIFICATIONS

C.4.01 Printer Dimensions

Width: 16.42"

Height: 7.09"

Depth: 22.44"

C.4.02 Printer Weight

37 lbs.

Copyright 1997, Okidata, Division of OKI America, Inc. All rights reserved. See the OKIDATA Business Partner Exchange (BPX) for any updates to this material. (<http://bpx.okidata.com>)



Service Guide ML393/ML393CPlus

Chapter C Microline 393/393C Specifications

C.5 POWER REQUIREMENTS

C.5.01 Input Power

Input Voltage

120 VAC +10%, -15%

220/240 +10%, -15%

Frequency

50/60 hz. +/-2%

C.5.02 Power Consumption

180 VA during Self-Test

Copyright 1997, Okidata, Division of OKI America, Inc. All rights reserved. See the OKIDATA Business Partner Exchange (BPX) for any updates to this material. (<http://bpx.okidata.com>)



Service Guide ML393/ML393CPlus

Chapter C Microline 393/393C Specifications

C.6 ENVIRONMENTAL CONDITIONS

C.6.01 Ambient Temperature and Relative Humidity

While in operation: 41°F to 104°F @ 20% - 80 % Relative Humidity

While in storage: -40°F to 158°F @ 5% - 95% Relative Humidity

C.6.02 Printer Noise Level (10 cpi - LQ Mode)

Standard noise level: 58 dba

Quite mode noise level: 55 dba

Copyright 1997, Okidata, Division of OKI America, Inc. All rights reserved. See the OKIDATA Business Partner Exchange (BPX) for any updates to this material. (<http://bpx.okidata.com>)



Service Guide ML393/ML393CPlus
Chapter C Microline 393/393C Specifications

C.7 AGENCY APPROVALS

C.7.01 Listings

North America

FCC Class B

UL 478 (Office Machines and Business Equipment)

CSA 22.2 154

Copyright 1997, Okidata, Division of OKI America, Inc. All rights reserved. See the OKIDATA Business Partner Exchange (BPX) for any updates to this material. (<http://bpx.okidata.com>)



Service Guide ML393/ML393CPlus

Chapter C Microline 393/393C Specifications

C.8 OPTIONS

C.8.01 Font Cartridges

Prestige

Gothic

C.8.02 RAM Cartridge

32 Kbytes

C.8.03 Cut Sheet Feeders

CSF 3001 - Single bin Cut Sheet Feeder

CSF 3002 - Dual bin Cut Sheet Feeder

C.8.04 Pull Tractor Assembly

The Pull Tractor Assembly is required for bottom feeding.

A Pull Tractor Assembly must be used to feed labels

Copyright 1997, Okidata, Division of OKI America, Inc. All rights reserved. See the OKIDATA Business Partner Exchange (BPX) for any updates to this material. (<http://bpx.okidata.com>)



Service Guide ML393/ML393CPlus

Chapter C Microline 393/393C Specifications

C.9 CONSUMABLES

C.9.01 Ribbon

Black Cartridge (Microline 393 and Microline 393C)

Type: Fabric Ribbon

Ribbon Life: 5 million characters

Color Cartridge (Microline 393C)

Type: Four band color ribbon (Yellow, Magenta, Cyan, Black)

Black: 2.3 million characters Ribbon Life

Cyan: 1.8 million characters Ribbon Life

Magenta: 1.8 million characters Ribbon Life

Yellow: 1.3 million characters Ribbon Life

Copyright 1997, Okidata, Division of OKI America, Inc. All rights reserved. See the OKIDATA Business Partner Exchange (BPX) for any updates to this material. (<http://bpx.okidata.com>)



Service Guide ML393/ML393CPlus

Chapter C Microline 393/393C Specifications

C.10 MEMORY SPECIFICATIONS

C.10.01 ROM

Resident: Program ROM = 128 Kbytes

Resident Fonts = 384 Kbytes

Optional Font Cartridges = 64 Kbytes each

C.10.02 RAM

Total RAM = 64 Kbytes

Print Buffer = 23 Kbytes

IBM I/F Buffer = 0 Kbyte minimum

Epson I/F Buffer = 8 Kbyte minimum

DLL Buffer = 0 to 32 Kbytes

C.10.03 EEPROM

Internal Control, Menu = 256 bits

Copyright 1997, Okidata, Division of OKI America, Inc. All rights reserved. See the OKIDATA Business Partner Exchange (BPX) for any updates to this material. (<http://bpx.okidata.com>)



Service Guide ML393/ML393CPlus

Chapter C Microline 393/393C Specifications

C.11 PRINTER RELIABILITY

C.11.01 Mean Time Before Failure (MTBF)

4,000 hours @ 25% Duty Cycle, 35% Page Density

C.11.02 Mean Time To Repair (MTTR)

15 minutes @ major sub-assembly level

C.11.03 Printer Life

12,000 hours @ 25% Duty, 35% Page Density

C.11.04 Printhead Life

200 Million Characters (average) @ 10 cpi Draft Mode @ 25% Duty Cycle, 35% Page Density

Copyright 1997, Okidata, Division of OKI America, Inc. All rights reserved. See the OKIDATA Business Partner Exchange (BPX) for any updates to this material. (<http://bpx.okidata.com>)